

Application Notes and Protocols for ABBV-383 in In Vivo Mouse Models

Author: BenchChem Technical Support Team. **Date:** April 2026

Compound of Interest

Compound Name: WS-383
Cat. No.: B10824560

[Get Quote](#)

Note on Compound Name: The initial query for "**WS-383**" yielded limited specific data for in vivo mouse models. However, a significant amount of research is available for "ABBV-383," a B-cell maturation antigen (BCMA) and CD3 bispecific antibody. This document provides detailed information on ABBV-383, assuming a potential user interest in this well-documented compound.

Introduction

ABBV-383 is an investigational bispecific antibody designed for the treatment of relapsed/refractory multiple myeloma (RRMM).[1][2] It functions as a T-cell engager by simultaneously binding to B-cell maturation antigen (BCMA) on myeloma cells and the CD3 receptor on T-cells.[3][4] This dual-targeting mechanism brings T-cells into close proximity with cancer cells, leading to T-cell activation and subsequent lysis of the myeloma cells.[4][5] Preclinical studies have demonstrated its antitumor activity with minimal cytokine release, and it is currently undergoing evaluation in clinical trials.[1]

Mechanism of Action

ABBV-383 is composed of bivalent high-avidity BCMA-binding domains and a low-affinity CD3-binding domain.[3] This design is intended to enhance the therapeutic window by maximizing

efficacy against myeloma cells while potentially reducing the incidence of cytokine release syndrome (CRS), a common side effect of T-cell engaging therapies.[4][6] The silenced Fc tail of the antibody contributes to an extended half-life.[3] BCMA is an ideal therapeutic target as it is highly expressed on the surface of malignant plasma cells and plays a crucial role in their survival and proliferation.[3][4]

Signaling Pathway Diagram

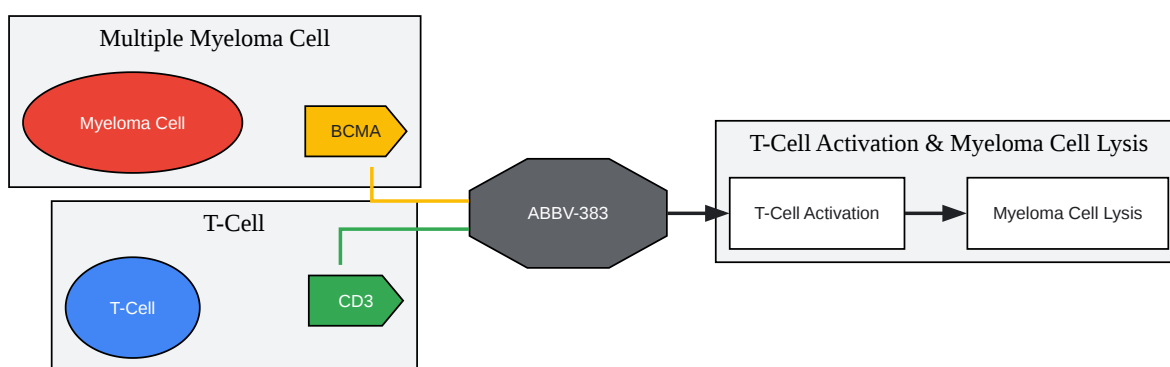

[Click to download full resolution via product page](#)

Caption: Mechanism of action of ABBV-383.

In Vivo Dosing and Administration

While specific preclinical dosage for mouse models is not detailed in the provided search results, information from the first-in-human clinical trial (NCT03933735) can be adapted to inform the design of such studies.[1][2]

Quantitative Data Summary

Parameter	Value	Reference
Clinical Trial Phase	Phase I, Dose Escalation/Expansion	[2]
Patient Population	Relapsed/Refractory Multiple Myeloma	[1][2]
Dose Escalation Range	0.025 - 120 mg	[2]
Dose Expansion Cohort	60 mg	[2]
Therapeutic Doses	≥ 40 mg	[1]
Administration Route	Intravenous (IV)	[2]
Dosing Schedule	Once every 3 weeks	[2]
Objective Response Rate (≥ 40 mg)	68%	[1]
Very Good Partial Response Rate (≥ 40 mg)	54%	[1]
Most Common Adverse Event	Cytokine Release Syndrome (57%)	[1]

Experimental Protocols

The following is a generalized protocol for an in vivo mouse study based on the clinical trial design for ABBV-383. This should be adapted based on the specific mouse model and research question.

Materials

- ABBV-383
- Sterile, pyrogen-free saline or other appropriate vehicle
- Multiple myeloma cell line (e.g., MM.1S)
- Immunocompromised mice (e.g., NSG mice)

- Standard laboratory equipment for cell culture, animal handling, and injections

Experimental Workflow

- Tumor Cell Implantation:
 - Culture the chosen multiple myeloma cell line under standard conditions.
 - Harvest and resuspend the cells in a suitable medium for injection.
 - Implant the tumor cells into the mice. For a disseminated myeloma model, this is typically done via intravenous (tail vein) injection.[\[7\]](#)
- Tumor Establishment and Monitoring:
 - Allow sufficient time for the tumors to establish and engraft.
 - Monitor tumor burden using methods such as bioluminescent imaging (BLI) if using a luciferase-expressing cell line.[\[7\]](#)
- Dosing Preparation:
 - Reconstitute or dilute ABBV-383 to the desired concentration in a sterile vehicle.
- Administration:
 - Administer ABBV-383 to the mice via intravenous injection.
 - The dosing schedule can be adapted from the clinical trial, for example, once every 3 weeks, or more frequently for mouse models.
- Monitoring and Data Collection:
 - Monitor the health of the mice regularly, including body weight and any signs of toxicity.
 - Continue to monitor tumor growth/regression using the established method (e.g., BLI).
 - Collect blood samples to analyze pharmacokinetics and pharmacodynamics (e.g., cytokine levels).

- At the end of the study, tissues can be harvested for further analysis (e.g., histology, flow cytometry).

Experimental Workflow Diagram

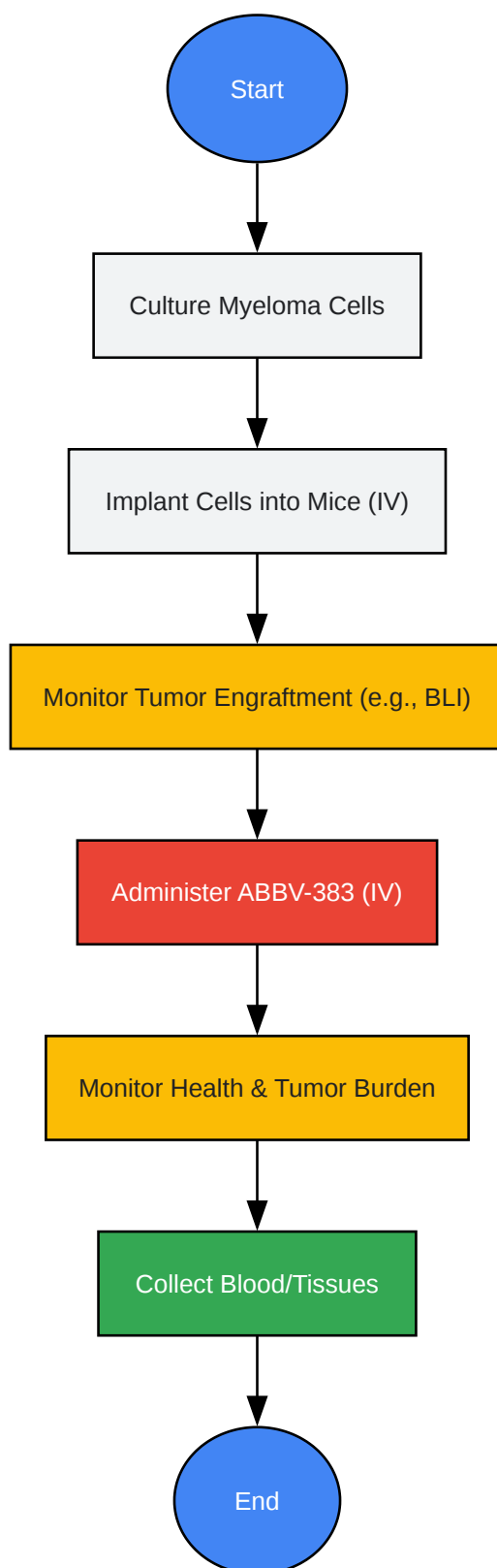

[Click to download full resolution via product page](#)

Caption: Generalized experimental workflow for ABBV-383 in a mouse model.

Need Custom Synthesis?

BenchChem offers custom synthesis for rare earth carbides and specific isotopic labeling.

Email: info@benchchem.com or [Request Quote Online](#).

References

- 1. A Phase I First-in-Human Study of ABBV-383, a B-Cell Maturation Antigen × CD3 Bispecific T-Cell Redirecting Antibody, in Patients With Relapsed/Refractory Multiple Myeloma - PMC [[pmc.ncbi.nlm.nih.gov](https://pubmed.ncbi.nlm.nih.gov/)]
- 2. A Phase I First-in-Human Study of ABBV-383, a B-Cell Maturation Antigen × CD3 Bispecific T-Cell Redirecting Antibody, in Patients With Relapsed/Refractory Multiple Myeloma - PubMed [pubmed.ncbi.nlm.nih.gov]
- 3. news.abbvie.com [news.abbvie.com]
- 4. m.youtube.com [m.youtube.com]
- 5. Ex vivo efficacy of BCMA-bispecific antibody TNB-383B in relapsed/refractory multiple myeloma - PMC [[pmc.ncbi.nlm.nih.gov](https://pubmed.ncbi.nlm.nih.gov/)]
- 6. P862: A PHASE 1 FIRST-IN-HUMAN MONOTHERAPY STUDY OF ABBV-383, A BCMA × CD3 BISPECIFIC T-CELL-REDIRECTING ANTIBODY, IN RELAPSED/REFRACTORY MULTIPLE MYELOMA - PMC [[pmc.ncbi.nlm.nih.gov](https://pubmed.ncbi.nlm.nih.gov/)]
- 7. In vivo quantitative assessment of therapeutic response to bortezomib therapy in disseminated animal models of multiple myeloma with [18F]FDG and [64Cu]Cu-LLP2A PET - PMC [[pmc.ncbi.nlm.nih.gov](https://pubmed.ncbi.nlm.nih.gov/)]
- To cite this document: BenchChem. [Application Notes and Protocols for ABBV-383 in In Vivo Mouse Models]. BenchChem, [2026]. [Online PDF]. Available at: [<https://www.benchchem.com/product/b10824560/docs#application-notes-and-protocols-for-abbv-383-in-in-vivo-mouse-models>]

Disclaimer & Data Validity:

The information provided in this document is for Research Use Only (RUO) and is strictly not intended for diagnostic or therapeutic procedures. While BenchChem strives to provide accurate protocols, we make no warranties, express or implied, regarding the fitness of this product for every specific experimental setup.

Technical Support: The protocols provided are for reference purposes. Unsure if this reagent suits your experiment?

Need Industrial/Bulk Grade? [Request Custom Synthesis Quote](#)

BenchChem

Our mission is to be the trusted global source of essential and advanced chemicals, empowering scientists and researchers to drive progress in science and industry.

Contact

Address: 3281 E Guasti Rd
Ontario, CA 91761, United States
Phone: (601) 213-4426
Email: info@benchchem.com

[Contact our Ph.D. Support Team for a compatibility check](#)