

Technical Support Center: In Vivo Applications of BSA-Cy5.5

Author: BenchChem Technical Support Team. **Date:** April 2026

Compound of Interest

Compound Name: *Bovine Serum Albumin-Cy5.5*

Cat. No.: *B10823030*

[Get Quote](#)

This technical support guide is intended for researchers, scientists, and drug development professionals utilizing BSA-Cy5.5 in in vivo imaging and biodistribution studies. It provides troubleshooting advice and frequently asked questions to help minimize non-specific binding and improve experimental outcomes.

Frequently Asked Questions (FAQs)

Q1: What are the primary causes of high non-specific binding of BSA-Cy5.5 in vivo?

A1: High non-specific binding of BSA-Cy5.5 in vivo can be attributed to several factors:

- **Hydrophobic Interactions:** The Cy5.5 dye is inherently hydrophobic and can non-specifically bind to hydrophobic regions of proteins and lipids in tissues.[1]
- **Electrostatic Interactions:** The overall charge of the BSA-Cy5.5 conjugate, which is dependent on the pH of the physiological environment, can lead to non-specific binding with charged molecules on cell surfaces or in the extracellular matrix.[2][3][4] For instance, positively charged molecules may interact with negatively charged cell membranes.[3]

- **Probe Aggregation:** Aggregates of BSA-Cy5.5 can be taken up non-specifically by the reticuloendothelial system (RES), particularly in the liver and spleen, leading to high background signal in these organs.
- **High Probe Concentration:** Injecting an excessively high concentration of the BSA-Cy5.5 conjugate can saturate specific binding sites and increase the likelihood of non-specific interactions.[1][5]
- **Inadequate Blocking:** If endogenous binding sites in tissues are not sufficiently blocked, the conjugate may bind non-specifically.

Q2: I am observing high background fluorescence in the liver and spleen. How can I reduce this?

A2: Accumulation in the liver and spleen is common for nanoparticles and protein conjugates. This is often due to uptake by macrophages of the RES. To mitigate this:

- **PEGylation:** Consider using a PEGylated version of BSA-Cy5.5. Polyethylene glycol (PEG) can shield the conjugate from RES uptake and prolong circulation time.
- **Optimize Dose:** Titrate the injected dose to the lowest effective concentration.
- **Control Injection Rate:** A slow intravenous injection can prevent the formation of aggregates that are rapidly cleared by the RES.
- **Pre-treatment with Blocking Agents:** In some cases, pre-dosing with a non-labeled blocking agent can help saturate RES clearance mechanisms, although this needs to be carefully validated for your specific model.

Q3: Can the charge of the BSA-Cy5.5 conjugate be modified to reduce non-specific binding?

A3: Yes, modifying the charge can be an effective strategy. The isoelectric point (pI) of BSA is approximately 4.7, meaning it is negatively charged at physiological pH (~7.4).[6] However, the conjugation process and the local tissue microenvironment can influence the effective charge. Strategies to consider include:

- **Chemical Modification:** Modifying the BSA molecule to alter its pI can be explored to make it more neutral or negatively charged to repel negatively charged cell surfaces.
- **Buffer Formulation:** While challenging for in vivo work, ensuring the formulation buffer pH is appropriate before injection is crucial. Adjusting the pH of the buffer can influence the overall charge of the biomolecule.[2][4]

Q4: Are there alternative blocking agents I can use in conjunction with my BSA-Cy5.5 studies?

A4: While BSA is a common blocking agent, other molecules can be used to reduce non-specific binding in vivo:

- **Non-ionic Surfactants:** Low concentrations of non-ionic surfactants like Tween 20 can help disrupt hydrophobic interactions.[2] However, their use in vivo must be carefully evaluated for toxicity and effects on probe biodistribution.
- **Synthetic Polymers:** Biocompatible and non-immunogenic synthetic polymers, such as those based on N-(2-hydroxypropyl)methacrylamide (HPMA), have been developed as effective blocking agents and alternatives to BSA.[7]
- **Fish Gelatin:** In some applications, fish gelatin shows low cross-reactivity with mammalian proteins and can be an effective blocker.[8]

Troubleshooting Guides

Problem 1: High Uniform Background Fluorescence

| Potential Cause | Troubleshooting Step | Rationale |
|-------------------------------|--|---|
| Excessive Probe Concentration | Perform a dose-response study to determine the optimal concentration of BSA-Cy5.5. | Using the lowest effective concentration minimizes the availability of unbound probe for non-specific interactions.[5] |
| Hydrophobic Interactions | Co-administer a low, non-toxic concentration of a biocompatible non-ionic surfactant (e.g., Tween 20). | Surfactants can disrupt non-specific hydrophobic binding of the Cy5.5 dye to tissues.[2] |
| Charge-based Interactions | Increase the salt concentration of the formulation buffer (e.g., with NaCl). | Higher salt concentrations can create a shielding effect, reducing electrostatic interactions between the charged conjugate and tissues.[2][4][9] |

Problem 2: Speckled or Punctate Non-specific Signal

| Potential Cause | Troubleshooting Step | Rationale |
|--|--|---|
| Probe Aggregation | Centrifuge the BSA-Cy5.5 solution at high speed (>10,000 x g) for 5-10 minutes immediately before injection. | This will pellet any pre-formed aggregates that can cause localized, intense non-specific signals.[1] |
| Filter the BSA-Cy5.5 solution through a 0.22 µm syringe filter before use. | This removes smaller aggregates and particulate contaminants. | |
| Precipitation in vivo | Ensure the formulation buffer is compatible with blood and physiological pH to prevent precipitation upon injection. | Incompatibility can lead to the formation of aggregates in the bloodstream. |

Experimental Protocols

Protocol: In Vivo Imaging with BSA-Cy5.5 and Reduction of Non-Specific Binding

- Probe Preparation and Quality Control:
 - Reconstitute lyophilized BSA-Cy5.5 in sterile, endotoxin-free PBS at pH 7.4.
 - Determine the concentration and degree of labeling using UV-Vis spectrophotometry. A typical labeling ratio is 2-7 Cy5.5 dyes per BSA molecule.[\[10\]](#)
 - Crucial Step: To remove aggregates, centrifuge the solution at 14,000 x g for 10 minutes at 4°C. Carefully collect the supernatant.
- Animal Preparation:
 - Anesthetize the animal (e.g., mouse) using an appropriate anesthetic protocol (e.g., isoflurane inhalation).
 - Maintain the animal's body temperature at 37°C throughout the imaging session.
- Injection and Imaging:
 - Acquire a baseline, pre-injection image of the animal.
 - Inject the prepared BSA-Cy5.5 solution intravenously (e.g., via the tail vein) at the predetermined optimal dose.
 - Acquire images at various time points post-injection (e.g., 5 min, 30 min, 1 hr, 4 hr, 24 hr) to assess biodistribution and clearance. The free Cy5.5 dye is typically cleared rapidly (within 24 hours), while BSA-conjugation will prolong circulation.[\[11\]](#)
- Ex Vivo Analysis (Optional but Recommended):
 - At the final time point, euthanize the animal.
 - Perfuse with saline to remove blood from the vasculature.
 - Harvest organs of interest (e.g., tumor, liver, spleen, kidneys, lungs).

- Image the harvested organs ex vivo to confirm in vivo findings and quantify signal distribution with higher sensitivity.

Visualizations

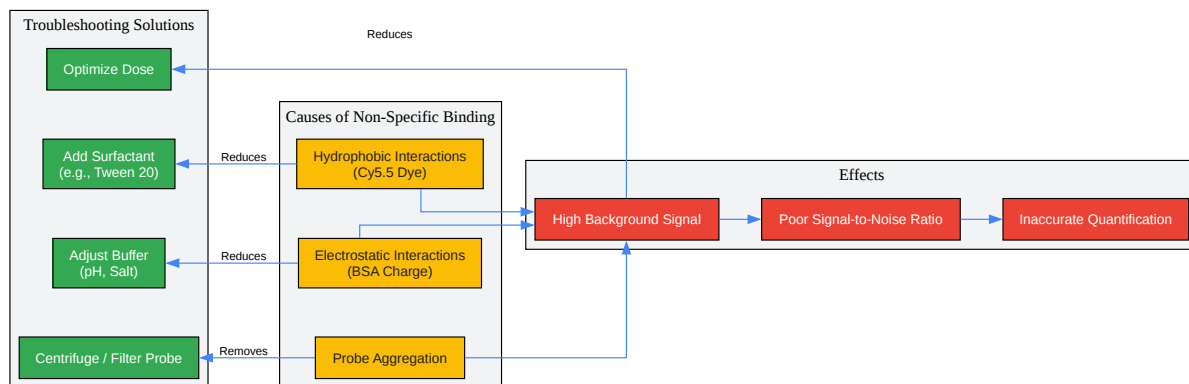

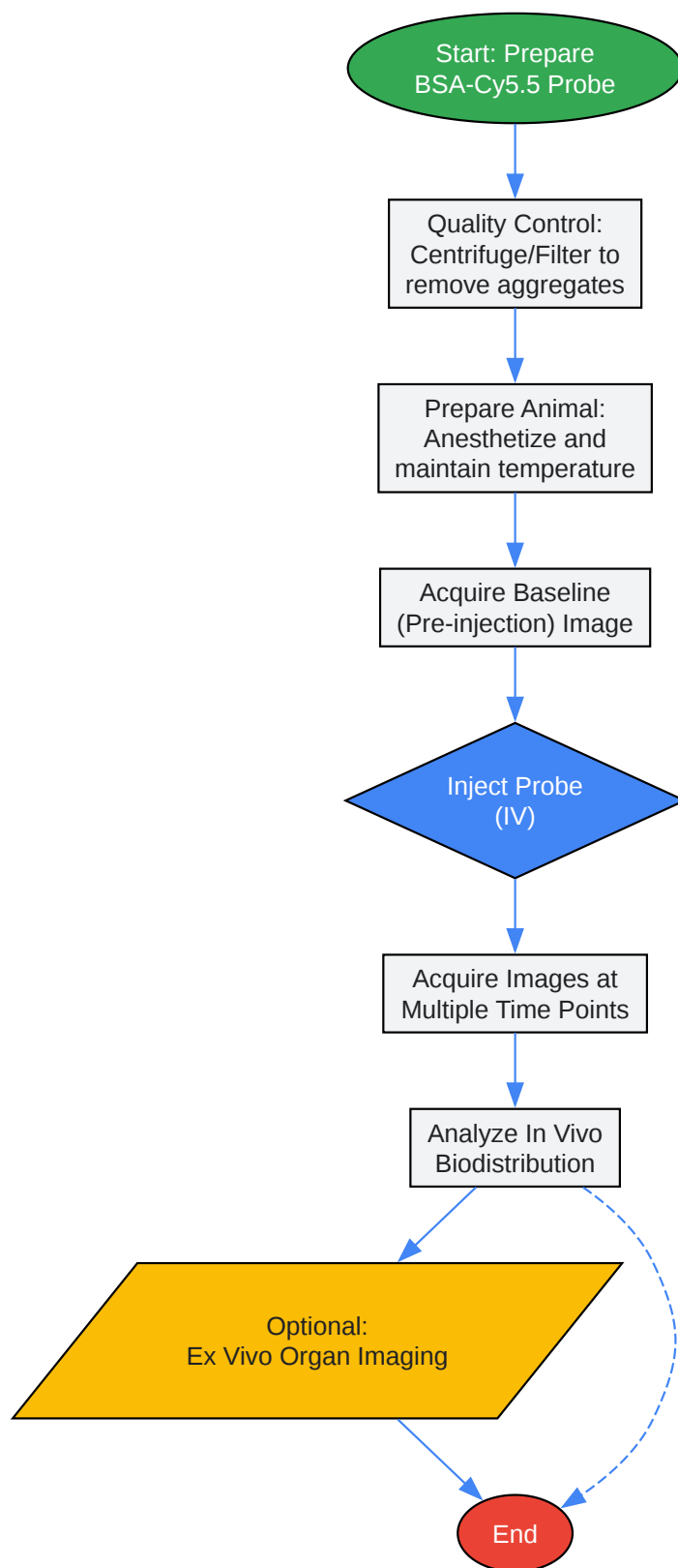

[Click to download full resolution via product page](#)

Need Custom Synthesis?

BenchChem offers custom synthesis for rare earth carbides and specific isotopic labeling.

Email: info@benchchem.com or [Request Quote Online](#).

References

- [1. benchchem.com](https://www.benchchem.com) [benchchem.com]
- [2. nicoyalife.com](https://www.nicoyalife.com) [nicoyalife.com]
- [3. Effect of variable domain charge on in vitro and in vivo disposition of monoclonal antibodies - PMC](#) [pmc.ncbi.nlm.nih.gov]
- [4. How to eliminate non-specific binding? | AAT Bioquest](#) [aatbio.com]
- [5. azurebiosystems.com](https://www.azurebiosystems.com) [azurebiosystems.com]
- [6. BSA Modification to Reduce CTAB Induced Nonspecificity and Cytotoxicity of Aptamer-Conjugated Gold Nanorods - PMC](#) [pmc.ncbi.nlm.nih.gov]
- [7. Highly Effective Synthetic Polymer-Based Blockers of Non-Specific Interactions in Immunochemical Analyses - PMC](#) [pmc.ncbi.nlm.nih.gov]
- [8. Reducing Non-Specific Binding in Western Blots: Blocking Agent Comparison](#) [synapse.patsnap.com]
- [9. Reddit - The heart of the internet](https://www.reddit.com) [reddit.com]
- [10. BSA, Cy5.5 labeled](https://www.nanocs.net) [nanocs.net]
- [11. Distribution and accumulation of Cy5.5-labeled thermally cross-linked superparamagnetic iron oxide nanoparticles in the tissues of ICR mice - PMC](#) [pmc.ncbi.nlm.nih.gov]
- To cite this document: BenchChem. [Technical Support Center: In Vivo Applications of BSA-Cy5.5]. BenchChem, [2026]. [Online PDF]. Available at: [\[https://www.benchchem.com/product/b10823030/docs#technical-support-center-in-vivo-applications-of-bsa-cy5-5\]](https://www.benchchem.com/product/b10823030/docs#technical-support-center-in-vivo-applications-of-bsa-cy5-5)

Disclaimer & Data Validity:

The information provided in this document is for Research Use Only (RUO) and is strictly not intended for diagnostic or therapeutic procedures. While BenchChem strives to provide

accurate protocols, we make no warranties, express or implied, regarding the fitness of this product for every specific experimental setup.

Technical Support: The protocols provided are for reference purposes. Unsure if this reagent suits your experiment?

Need Industrial/Bulk Grade? [Request Custom Synthesis Quote](#)

BenchChem

Our mission is to be the trusted global source of essential and advanced chemicals, empowering scientists and researchers to drive progress in science and industry.

Contact

Address: 3281 E Guasti Rd
Ontario, CA 91761, United States
Phone: (601) 213-4426
Email: info@benchchem.com

[Contact our Ph.D. Support Team for a compatibility check](#)