

SR-0813: A Comparative Analysis of Selectivity Against Bromodomains

Author: BenchChem Technical Support Team. **Date:** April 2026

Compound of Interest

Compound Name: SR-0813
Cat. No.: B10823721

[Get Quote](#)

SR-0813 has emerged as a potent and highly selective chemical probe for the ENL/AF9 YEATS domains, playing a crucial role in advancing research into acute leukemia.^{[1][2][3][4]} This guide provides a detailed comparison of **SR-0813**'s binding affinity and selectivity against other bromodomains, supported by experimental data and methodologies.

Quantitative Selectivity Profile of SR-0813

The selectivity of **SR-0813** has been rigorously evaluated across various protein families, demonstrating a remarkable specificity for the ENL and AF9 YEATS domains. The following table summarizes the key quantitative data from biochemical and cellular assays.

Target Domain	Assay Type	Metric	Value (nM)	Selectivity Note
ENL YEATS Domain	HTRF	IC50	25	Potent Inhibition
SPR	Kd	30	High Affinity	
CETSA	EC50	205	Target Engagement in Cells	
AF9 YEATS Domain	HTRF	IC50	311	Potent Inhibition
CETSA	EC50	76	Target Engagement in Cells	
YEATS2 & YEATS4 Domains	Peptide Array & SPR	-	-	Highly selective against[1][3][5]
BRD4 BD1	HTRF	-	-	Inactive[1][5][6]
32 Bromodomains	BROMOscan®	% Ctrl @ 10 µM	>90% for all	No off-targets identified[1][3][5][6]
YSK4 (MAP3K19) Kinase	KINOMEScan	Kd	3,500	Over 100-fold lower affinity than ENL[1][3]
467 Other Kinases	KINOMEScan	% Ctrl @ 10 µM	>90% for most	Minimal off-targets identified[1]

- IC50: Half-maximal inhibitory concentration.
- Kd: Dissociation constant, a measure of binding affinity.

- EC50: Half-maximal effective concentration in cellular assays.
- CETSA: Cellular Thermal Shift Assay.
- HTRF: Homogeneous Time-Resolved Fluorescence.
- SPR: Surface Plasmon Resonance.
- BROMOscan® & KINOMEScan: Commercially available binding assays.

SR-0813 demonstrates potent inhibition of both ENL and AF9 YEATS domains.^{[1][2][7]} While HTRF assays suggest a preference for ENL (IC50 of 25 nM) over AF9 (IC50 of 311 nM), cellular target engagement measured by CETSA indicates potent activity against both (EC50 of 205 nM for ENL and 76 nM for AF9), suggesting **SR-0813** is a dual inhibitor of ENL and AF9 in cells.^{[1][3][5]}

Crucially, **SR-0813** shows exceptional selectivity against other protein families that recognize acetylated lysine residues. A comprehensive screen against 32 bromodomains using the BROMOscan® service revealed no significant off-target binding.^{[1][3][5][6]} Furthermore, it was found to be inactive against the BRD4 bromodomain 1 (BD1) in an HTRF assay.^{[1][5][6]} Its selectivity extends to other YEATS domain family members, YEATS2 and YEATS4.^{[1][3][5]} While **SR-0813** shares a core structure with some kinase inhibitors, a KINOMEScan profiling against 468 kinases identified only a few potential off-targets, with the most significant, YSK4 (MAP3K19), having a binding affinity over 100 times weaker than for the ENL YEATS domain.^{[1][3]}

Experimental Workflow for Selectivity Profiling

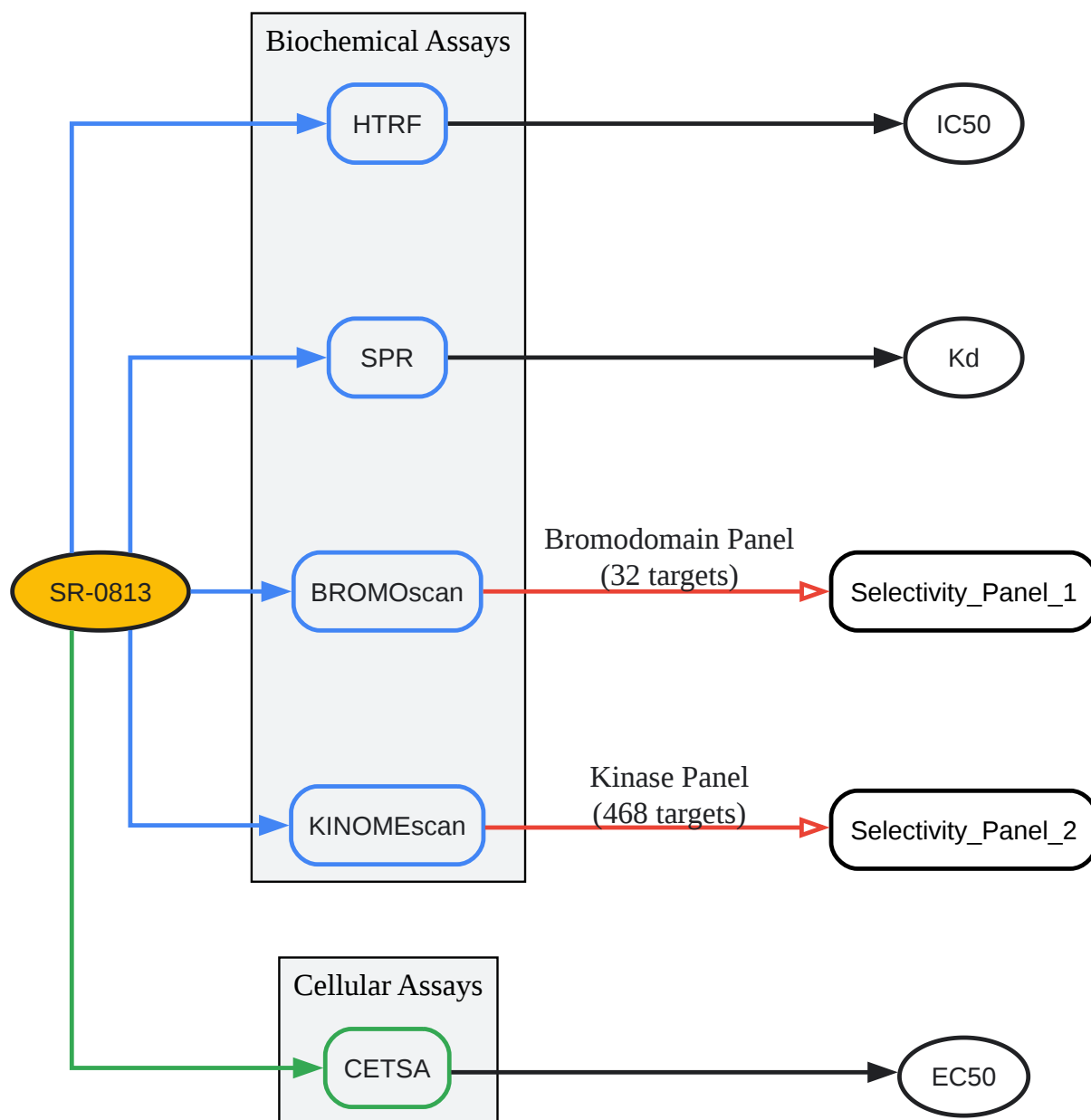

[Click to download full resolution via product page](#)

Caption: Workflow for assessing **SR-0813** selectivity.

Detailed Experimental Protocols

The comprehensive evaluation of **SR-0813**'s selectivity involved several key experimental methodologies:

- **BROMOScan® Profiling:** This is a competitive binding assay used to determine the interaction of a test compound (**SR-0813**) with a panel of bromodomains. In this assay, bromodomains are tagged and immobilized on a solid support. The ability of **SR-0813** to compete with a known ligand for binding to each bromodomain is measured. A lack of displacement of the known ligand indicates that the test compound does not bind to that particular bromodomain, thus demonstrating selectivity. For **SR-0813**, this was performed against a panel of 32 bromodomains.[\[1\]](#)[\[3\]](#)[\[5\]](#)
- **Homogeneous Time-Resolved Fluorescence (HTRF) Assay:** HTRF is a proximity-based assay that measures the binding of a protein to its substrate. In the context of **SR-0813**, this assay was used to determine the IC50 values against ENL and AF9 YEATS domains. Typically, a GST-tagged bromodomain is recognized by a donor fluorophore-coupled antibody, and a biotinylated acetylated peptide substrate is recognized by an acceptor fluorophore-coupled streptavidin.[\[8\]](#) When the bromodomain and substrate interact, the donor and acceptor fluorophores are brought into close proximity, allowing for Fluorescence Resonance Energy Transfer (FRET). An inhibitor like **SR-0813** disrupts this interaction, leading to a decrease in the FRET signal.
- **Cellular Thermal Shift Assay (CETSA):** CETSA is used to verify the engagement of a compound with its target protein within a cellular environment. The principle is that a protein becomes more thermally stable when a ligand is bound to it. In this assay, cells are treated with the compound of interest (**SR-0813**) and then heated to various temperatures. The amount of soluble protein remaining at each temperature is then quantified. A shift in the melting temperature of the target protein in the presence of the compound indicates target engagement. This method was used to determine the EC50 values for **SR-0813** against ENL and AF9 in cells.[\[1\]](#)[\[3\]](#)[\[5\]](#)
- **KINOMEScan™ Profiling:** This is a competitive binding assay similar to BROMOScan®, but for screening against a large panel of kinases. A test compound is profiled for its ability to compete with an immobilized active site-directed ligand for binding to the kinase. The amount of kinase bound to the solid support is measured, and a reduced amount in the presence of the test compound indicates binding. **SR-0813** was screened against a panel of 468 kinases to assess its kinase selectivity.[\[1\]](#)[\[3\]](#)

SR-0813 Selectivity Profile

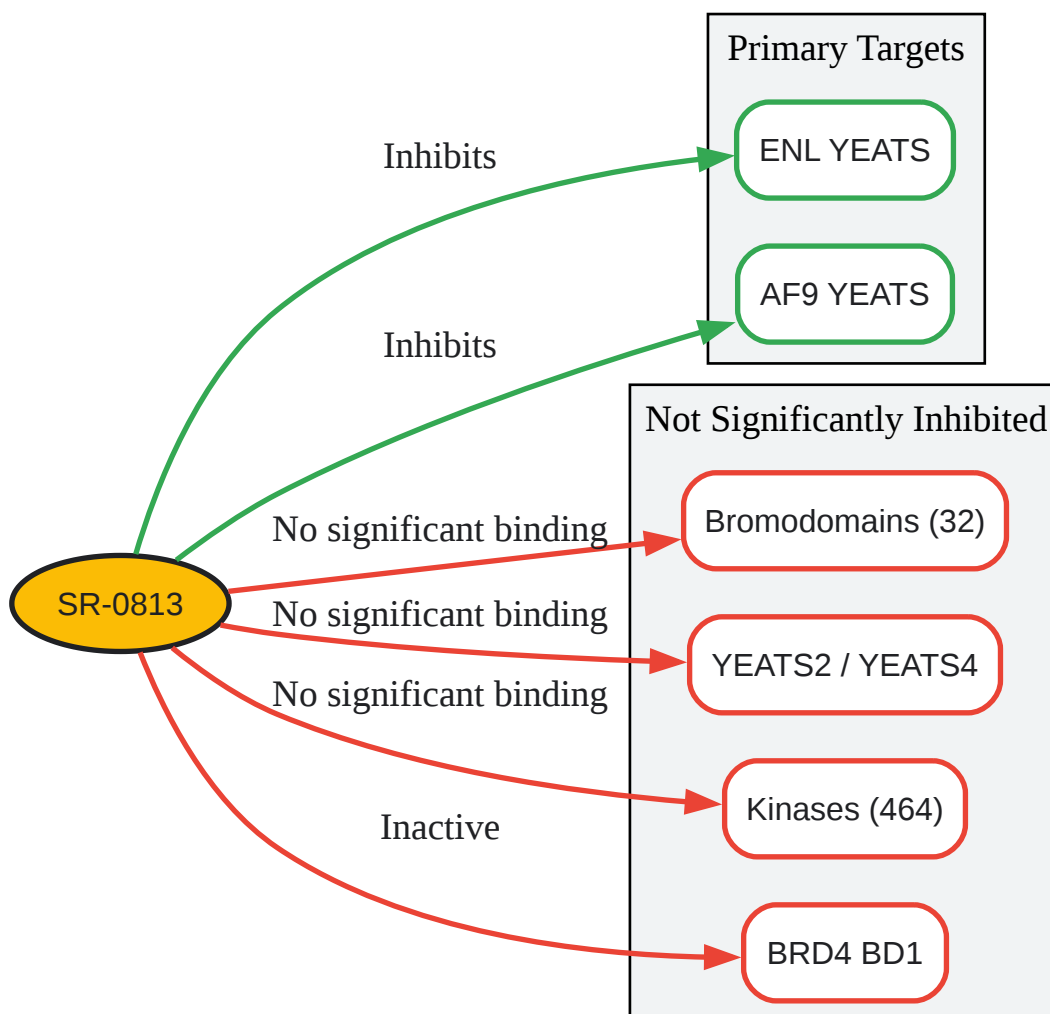

[Click to download full resolution via product page](#)

Caption: **SR-0813** demonstrates high selectivity for ENL/AF9.

Need Custom Synthesis?

BenchChem offers custom synthesis for rare earth carbides and specific isotopic labeling.

Email: info@benchchem.com or [Request Quote Online](#).

References

- [1. pubs.acs.org \[pubs.acs.org\]](https://pubs.acs.org)
- [2. medchemexpress.com \[medchemexpress.com\]](https://medchemexpress.com)
- [3. Chemical Inhibition of ENL/AF9 YEATS Domains in Acute Leukemia - PMC \[pmc.ncbi.nlm.nih.gov\]](https://pubmed.ncbi.nlm.nih.gov/36123456/)
- [4. Chemical Inhibition of ENL/AF9 YEATS Domains in Acute Leukemia - PubMed \[pubmed.ncbi.nlm.nih.gov\]](https://pubmed.ncbi.nlm.nih.gov/36123456/)
- [5. researchgate.net \[researchgate.net\]](https://www.researchgate.net)
- [6. researchgate.net \[researchgate.net\]](https://www.researchgate.net)
- [7. SR-0813 - Ace Therapeutics \[acetherapeutics.com\]](https://www.acetherapeutics.com)
- [8. reactionbiology.com \[reactionbiology.com\]](https://www.reactionbiology.com)
- To cite this document: BenchChem. [SR-0813: A Comparative Analysis of Selectivity Against Bromodomains]. BenchChem, [2026]. [Online PDF]. Available at: [\[https://www.benchchem.com/product/b10823721/docs#sr-0813-a-comparative-analysis-of-selectivity-against-bromodomains\]](https://www.benchchem.com/product/b10823721/docs#sr-0813-a-comparative-analysis-of-selectivity-against-bromodomains)

Disclaimer & Data Validity:

The information provided in this document is for Research Use Only (RUO) and is strictly not intended for diagnostic or therapeutic procedures. While BenchChem strives to provide accurate protocols, we make no warranties, express or implied, regarding the fitness of this product for every specific experimental setup.

Technical Support: The protocols provided are for reference purposes. Unsure if this reagent suits your experiment?

Need Industrial/Bulk Grade? [Request Custom Synthesis Quote](#)

BenchChem

Our mission is to be the trusted global source of essential and advanced chemicals, empowering scientists and researchers to drive progress in science and industry.

Contact

Address: 3281 E Guasti Rd
Ontario, CA 91761, United States
Phone: (601) 213-4426
Email: info@benchchem.com

Contact our Ph.D. Support Team for a compatibility check