

Comparative Analysis of SHP2 Antibody Specificity with SHP1

Author: BenchChem Technical Support Team. **Date:** April 2026

Compound of Interest

Compound Name: SHP2-D26

Cat. No.: B10823995

[Get Quote](#)

For Immediate Release

This guide provides a detailed comparison of the specificity of a widely used SHP2 antibody, focusing on its potential cross-reactivity with the closely related protein tyrosine phosphatase, SHP1. The information presented is intended for researchers, scientists, and drug development professionals who require highly specific reagents for their studies of SHP2-mediated signaling pathways.

Introduction to SHP1 and SHP2

Src homology region 2 domain-containing phosphatase 1 (SHP1) and SHP2 are two highly homologous non-receptor protein tyrosine phosphatases that play critical, yet often opposing, roles in intracellular signaling. Both enzymes contain two tandem SH2 domains and a C-terminal catalytic PTP domain. SHP1 is primarily expressed in hematopoietic cells and generally acts as a negative regulator of signaling pathways, including those involved in inflammation and cell growth. In contrast, SHP2 is ubiquitously expressed and typically functions as a positive regulator of signaling cascades, such as the RAS-MAPK pathway, promoting cell survival and proliferation. Given their structural similarity, the specificity of

antibodies used to detect and isolate these proteins is of paramount importance for accurate experimental results.

Featured Antibody

This guide focuses on the SHP-2 (D50F2) Rabbit mAb (Cell Signaling Technology, #3397), a recombinant monoclonal antibody raised against a synthetic peptide corresponding to the carboxy-terminal sequence of human SHP2.[1]

Specificity Assessment: SHP-2 (D50F2) Rabbit mAb

The specificity of the SHP-2 (D50F2) Rabbit mAb has been rigorously validated using knockout (KO) cell lines, which is considered a gold standard for antibody validation.

Experimental Data

The following table summarizes the key findings from the specificity validation of the SHP-2 (D50F2) Rabbit mAb.

Target Protein	Antibody	Experimental Method	Cell Line	Result	Cross-Reactivity with SHP1	Reference
SHP2	SHP-2 (D50F2) Rabbit mAb	Western Blot	Control 293T cells	Strong band detected at ~72 kDa	Not explicitly tested against purified SHP1, but KO validation provides strong evidence of specificity.	[1]
SHP2	SHP-2 (D50F2) Rabbit mAb	Western Blot	SHP-2 knockout 293T cells	No band detected	N/A	[1]

Conclusion: The absence of a signal in the SHP-2 knockout 293T cells provides strong evidence for the high specificity of the SHP-2 (D50F2) Rabbit mAb for its intended target.^[1] While direct binding to SHP1 has not been explicitly shown in a head-to-head comparison, the knockout validation strongly suggests a lack of significant cross-reactivity.

Experimental Protocols

Detailed methodologies for key experiments are provided below.

Western Blotting

This protocol is adapted from Cell Signaling Technology's general Western blotting protocol.

1. Sample Preparation:

- Culture control and SHP-2 knockout 293T cells to 80-90% confluence.
- Lyse cells in 1X SDS sample buffer.
- Sonicate the lysate to shear DNA and reduce viscosity.
- Heat the samples to 95-100°C for 5 minutes, then cool on ice.
- Centrifuge to pellet cellular debris.

2. SDS-PAGE and Transfer:

- Load 20 µL of the supernatant onto a precast SDS-polyacrylamide gel.
- Perform electrophoresis to separate proteins by size.
- Transfer the separated proteins to a nitrocellulose membrane.

3. Immunoblotting:

- Block the membrane with 5% w/v BSA or nonfat dry milk in Tris-buffered saline with 0.1% Tween® 20 (TBST) for 1 hour at room temperature.
- Incubate the membrane with the SHP-2 (D50F2) Rabbit mAb at a 1:1000 dilution in blocking buffer overnight at 4°C with gentle agitation.
- Wash the membrane three times for 5 minutes each with TBST.
- Incubate the membrane with an HRP-conjugated anti-rabbit secondary antibody for 1 hour at room temperature.
- Wash the membrane three times for 5 minutes each with TBST.

4. Detection:

- Incubate the membrane with a chemiluminescent HRP substrate.
- Capture the signal using an appropriate imaging system.

Immunoprecipitation

This protocol is a general guide for immunoprecipitation using the SHP-2 (D50F2) Rabbit mAb.

1. Cell Lysate Preparation:

- Harvest cells and lyse in a non-denaturing lysis buffer supplemented with protease and phosphatase inhibitors.
- Centrifuge the lysate to pellet cellular debris and collect the supernatant.

2. Immunoprecipitation:

- Pre-clear the cell lysate by incubating with protein A/G agarose/magnetic beads for 30-60 minutes at 4°C.
- Add the SHP-2 (D50F2) Rabbit mAb to the pre-cleared lysate at a 1:50 dilution and incubate overnight at 4°C with gentle rotation.
- Add fresh protein A/G beads to the lysate-antibody mixture and incubate for 1-3 hours at 4°C to capture the immune complexes.
- Pellet the beads by centrifugation and wash five times with lysis buffer.

3. Elution and Analysis:

- Elute the bound proteins from the beads by resuspending in 1X SDS sample buffer and heating to 95-100°C for 5 minutes.
- Analyze the eluted proteins by Western blotting as described above.

Signaling Pathways and Experimental Workflow Diagrams

The following diagrams illustrate the distinct signaling pathways of SHP1 and SHP2, and a typical experimental workflow for antibody validation.

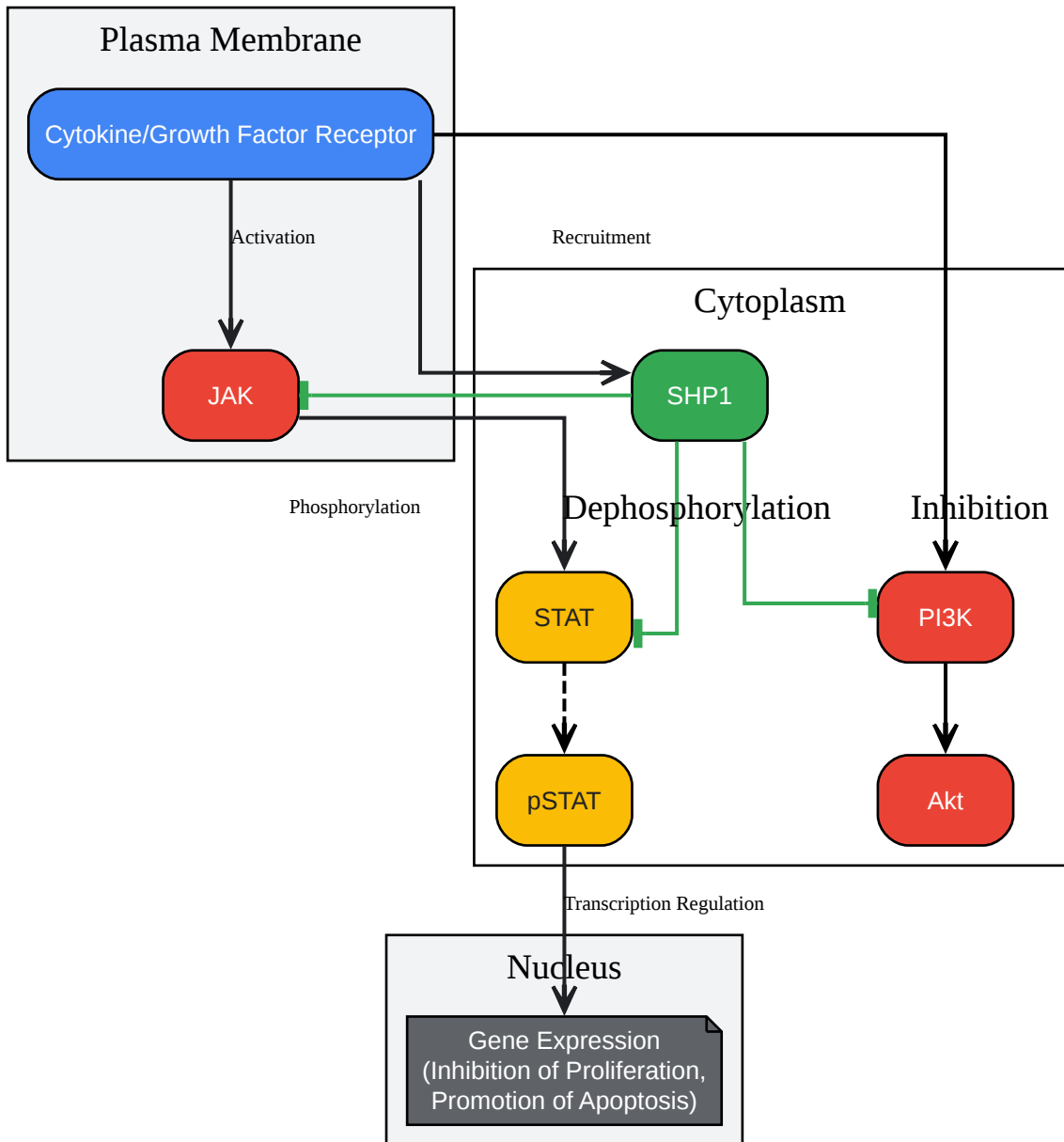

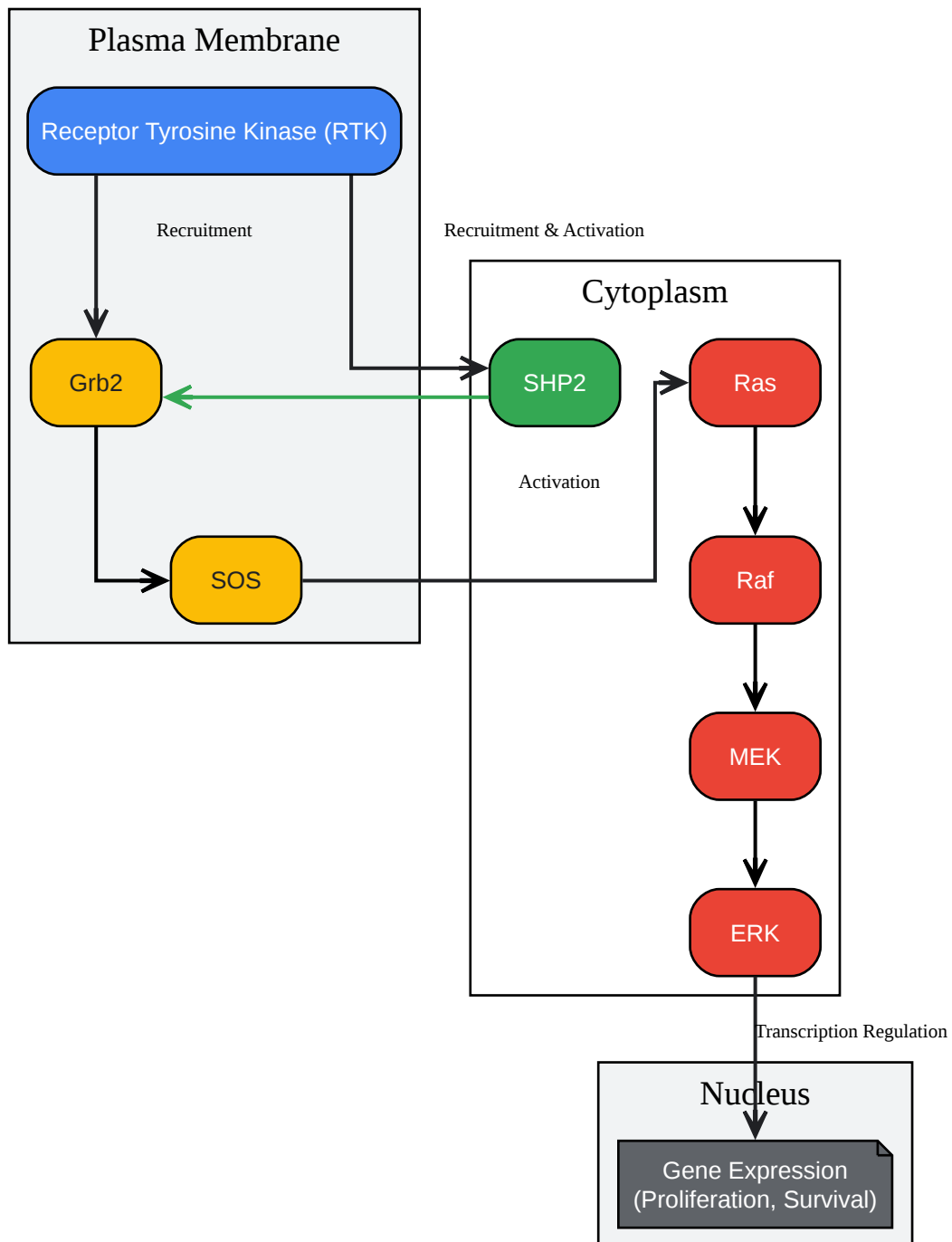

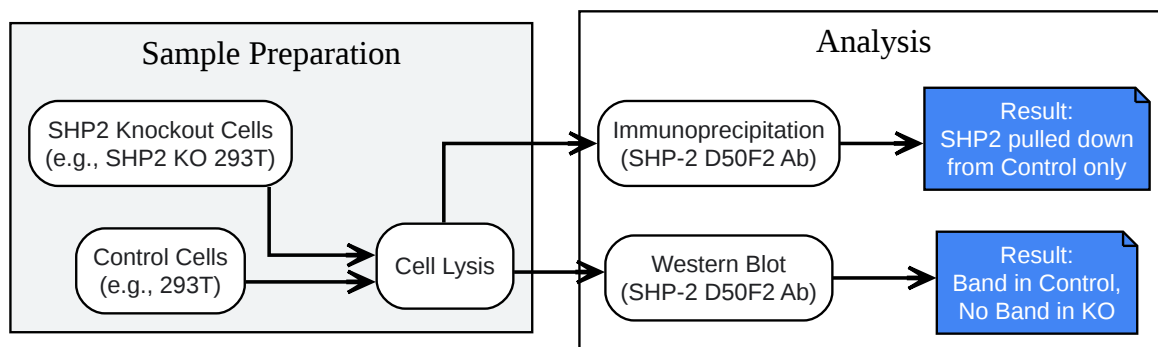

[Click to download full resolution via product page](#)

Need Custom Synthesis?

BenchChem offers custom synthesis for rare earth carbides and specific isotopic labeling.

Email: info@benchchem.com or [Request Quote Online](#).

References

- 1. SHP-2 (D50F2) Rabbit Monoclonal Antibody | Cell Signaling Technology [cellsignal.com]
- To cite this document: BenchChem. [Comparative Analysis of SHP2 Antibody Specificity with SHP1]. BenchChem, [2026]. [Online PDF]. Available at: [\[https://www.benchchem.com/product/b10823995/docs#comparative-analysis-of-shp2-antibody-specificity-with-shp1\]](https://www.benchchem.com/product/b10823995/docs#comparative-analysis-of-shp2-antibody-specificity-with-shp1)

Disclaimer & Data Validity:

The information provided in this document is for Research Use Only (RUO) and is strictly not intended for diagnostic or therapeutic procedures. While BenchChem strives to provide accurate protocols, we make no warranties, express or implied, regarding the fitness of this product for every specific experimental setup.

Technical Support: The protocols provided are for reference purposes. Unsure if this reagent suits your experiment?

Need Industrial/Bulk Grade? [Request Custom Synthesis Quote](#)

BenchChem

Our mission is to be the trusted global source of essential and advanced chemicals, empowering scientists and researchers to drive progress in science and industry.

Contact

Address: 3281 E Guasti Rd
Ontario, CA 91761, United States
Phone: (601) 213-4426
Email: info@benchchem.com

[Contact our Ph.D. Support Team for a compatibility check](#)