

improving MBM-55 stability in culture media

Author: BenchChem Technical Support Team. **Date:** April 2026

Compound of Interest

Compound Name: MBM-55
Cat. No.: B10821444

[Get Quote](#)

Technical Support Center: MBM-55

For Researchers, Scientists, and Drug Development Professionals

This technical support center provides comprehensive troubleshooting guides and frequently asked questions (FAQs) to address potential stability issues with the Nek2 inhibitor, **MBM-55**, in cell culture media. Our goal is to help you ensure the consistency and reliability of your experimental results.

Frequently Asked Questions (FAQs)

Q1: My experimental results with **MBM-55** are inconsistent. Could this be due to compound instability?

A1: Yes, inconsistent results are a common indicator of compound instability in cell culture media. Small molecules like **MBM-55** can degrade over time, which can lead to a decreased effective concentration of the active compound and the potential for off-target effects from degradation products. Factors such as the pH of the medium, incubation temperature (37°C), and the presence of serum enzymes can all contribute to degradation.

Q2: What are the typical signs of **MBM-55** degradation in my cell culture experiments?

A2: Signs of **MBM-55** degradation can include:

- Reduced or variable biological activity in your assays.
- The need for higher concentrations of the compound to achieve the expected effect.
- Changes in the color or clarity of the culture medium containing **MBM-55**.
- The appearance of unexpected peaks when analyzing samples by HPLC or LC-MS.

Q3: How should I properly store and handle **MBM-55** to maximize its stability?

A3: For optimal stability, **MBM-55** should be stored under the following conditions:

- Solid form: Store at -20°C for long-term storage (months to years) and at 0-4°C for short-term storage (days to weeks). The product should be kept dry and in the dark.[1]
- Stock solutions: Prepare stock solutions in a suitable solvent, such as DMSO.[1][2] Store these stock solutions at -20°C for long-term storage or at 0-4°C for short-term use.[1] Minimize freeze-thaw cycles.

Q4: Can components of the cell culture medium affect the stability of **MBM-55**?

A4: Yes, various components in cell culture media can impact the stability of small molecules. For instance, serum contains enzymes that can metabolize compounds. The pH of the medium can also influence the rate of hydrolysis of certain chemical bonds. It is advisable to test the stability of **MBM-55** in your specific cell culture medium, both with and without serum, if you suspect instability.

Q5: What are the known off-target effects of **MBM-55**?

A5: **MBM-55** is a potent inhibitor of Nek2 with an IC₅₀ of 1 nM. It shows high selectivity but does have some off-target activity against RSK1 (IC₅₀=5.4 nM) and DYRK1a (IC₅₀=6.5 nM). [3] Researchers should consider these off-target effects when interpreting experimental data.

Troubleshooting Guide

This guide provides a systematic approach to identifying and mitigating potential stability issues with **MBM-55** in your experiments.

Problem	Possible Cause	Recommended Solution
Inconsistent biological activity	MBM-55 degradation in culture medium.	<ol style="list-style-type: none">1. Perform a stability study: Use the provided experimental protocol to determine the half-life of MBM-55 in your specific culture medium and conditions.2. Prepare fresh solutions: Prepare fresh dilutions of MBM-55 from a frozen stock solution immediately before each experiment.3. Minimize incubation time: If MBM-55 is found to be unstable, reduce the incubation time of the compound with the cells as much as possible.4. Consider serum-free media: If your cell line permits, consider using serum-free or reduced-serum media to minimize enzymatic degradation.
Precipitation of MBM-55 in culture medium	Poor solubility at the working concentration.	<ol style="list-style-type: none">1. Check solubility: MBM-55 is soluble in DMSO.^{[1][2]} Ensure the final concentration of DMSO in your culture medium is low (typically <0.5%) to avoid solvent toxicity.2. Optimize dilution: Perform serial dilutions of your stock solution in pre-warmed culture medium. Avoid adding a highly concentrated stock directly to a large volume of aqueous medium.3. Visual inspection: After adding MBM-55 to the

medium, visually inspect for any precipitate. If observed, you may need to lower the working concentration or try a different formulation approach (though options are limited for in-vitro work).

Unexpected cellular phenotypes

Activity of degradation products or off-target effects.

1. Confirm MBM-55 integrity: Analyze your MBM-55 working solution by HPLC or LC-MS to check for the presence of degradation products. 2. Review off-target profile: Be aware of the known off-targets of MBM-55 (RSK1 and DYRK1a) and consider if their inhibition could explain the observed phenotype.^[3] 3. Use a structurally different Nek2 inhibitor: As a control, use a different Nek2 inhibitor to see if the same phenotype is observed.

Quantitative Data on MBM-55 Stability

Currently, there is a lack of publicly available quantitative data on the stability of **MBM-55** in various cell culture media under standard incubation conditions (37°C, 5% CO₂). The stability of a compound can be highly dependent on the specific experimental conditions. Therefore, we strongly recommend that researchers determine the stability of **MBM-55** in their particular system using the protocol provided below.

Table 1: Stability of **MBM-55** in Cell Culture Media (Template for Experimental Data)

Culture Medium	Serum Concentration (%)	Incubation Time (hours)	MBM-55 Remaining (%)	Half-life (t _{1/2}) (hours)
e.g., DMEM	e.g., 10% FBS	e.g., 0	e.g., 100%	e.g., To be determined
e.g., 2				
e.g., 4				
e.g., 8				
e.g., 24				
e.g., 48				
e.g., RPMI-1640	e.g., 10% FBS	e.g., 0	e.g., 100%	e.g., To be determined
e.g., 2				
e.g., 4				
e.g., 8				
e.g., 24				
e.g., 48				

Experimental Protocols

Protocol for Assessing MBM-55 Stability in Culture Media

This protocol outlines a method to determine the stability of **MBM-55** in your specific cell culture medium using High-Performance Liquid Chromatography (HPLC) or Liquid Chromatography-Mass Spectrometry (LC-MS).

Materials:

- **MBM-55**

- Your cell culture medium of choice (e.g., DMEM, RPMI-1640)
- Fetal Bovine Serum (FBS), if applicable
- Sterile microcentrifuge tubes or a 96-well plate
- Incubator (37°C, 5% CO₂)
- HPLC or LC-MS system
- Acetonitrile or other suitable organic solvent for protein precipitation and sample dilution
- Analytical standards of **MBM-55**

Methodology:

- Preparation of **MBM-55** Working Solution:
 - Prepare a stock solution of **MBM-55** in DMSO (e.g., 10 mM).
 - Dilute the stock solution in your chosen culture medium (with or without serum) to the final working concentration you use in your experiments (e.g., 1 μM).
- Incubation:
 - Aliquot the **MBM-55** working solution into sterile microcentrifuge tubes or wells of a 96-well plate.
 - Incubate the samples at 37°C in a 5% CO₂ incubator.
 - At designated time points (e.g., 0, 2, 4, 8, 24, 48 hours), remove an aliquot for analysis. The t=0 sample should be processed immediately without incubation.
- Sample Processing:
 - For samples containing serum, precipitate proteins by adding 2-3 volumes of cold acetonitrile.

- Vortex the samples and centrifuge at high speed (e.g., 14,000 rpm for 10 minutes) to pellet the precipitated proteins.
- Transfer the supernatant to a clean tube or an HPLC vial.
- For serum-free samples, protein precipitation may not be necessary, but a centrifugation step is still recommended to remove any potential particulates.
- Analysis by HPLC or LC-MS:
 - Analyze the samples using a validated HPLC or LC-MS method capable of separating **MBM-55** from potential degradation products.
 - Quantify the peak area of the parent **MBM-55** compound at each time point.
- Data Analysis:
 - Normalize the peak area of **MBM-55** at each time point to the peak area at t=0.
 - Plot the percentage of **MBM-55** remaining versus time.
 - Calculate the half-life ($t_{1/2}$) of **MBM-55** in the culture medium.

Visualizations

Nek2 Signaling Pathway in Mitosis

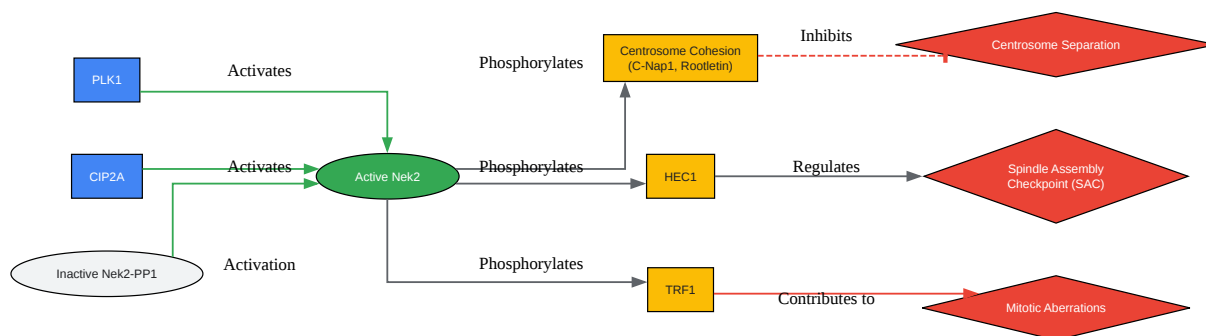

[Click to download full resolution via product page](#)

Caption: Nek2 signaling pathway in mitotic regulation.

Experimental Workflow for MBM-55 Stability Assessment

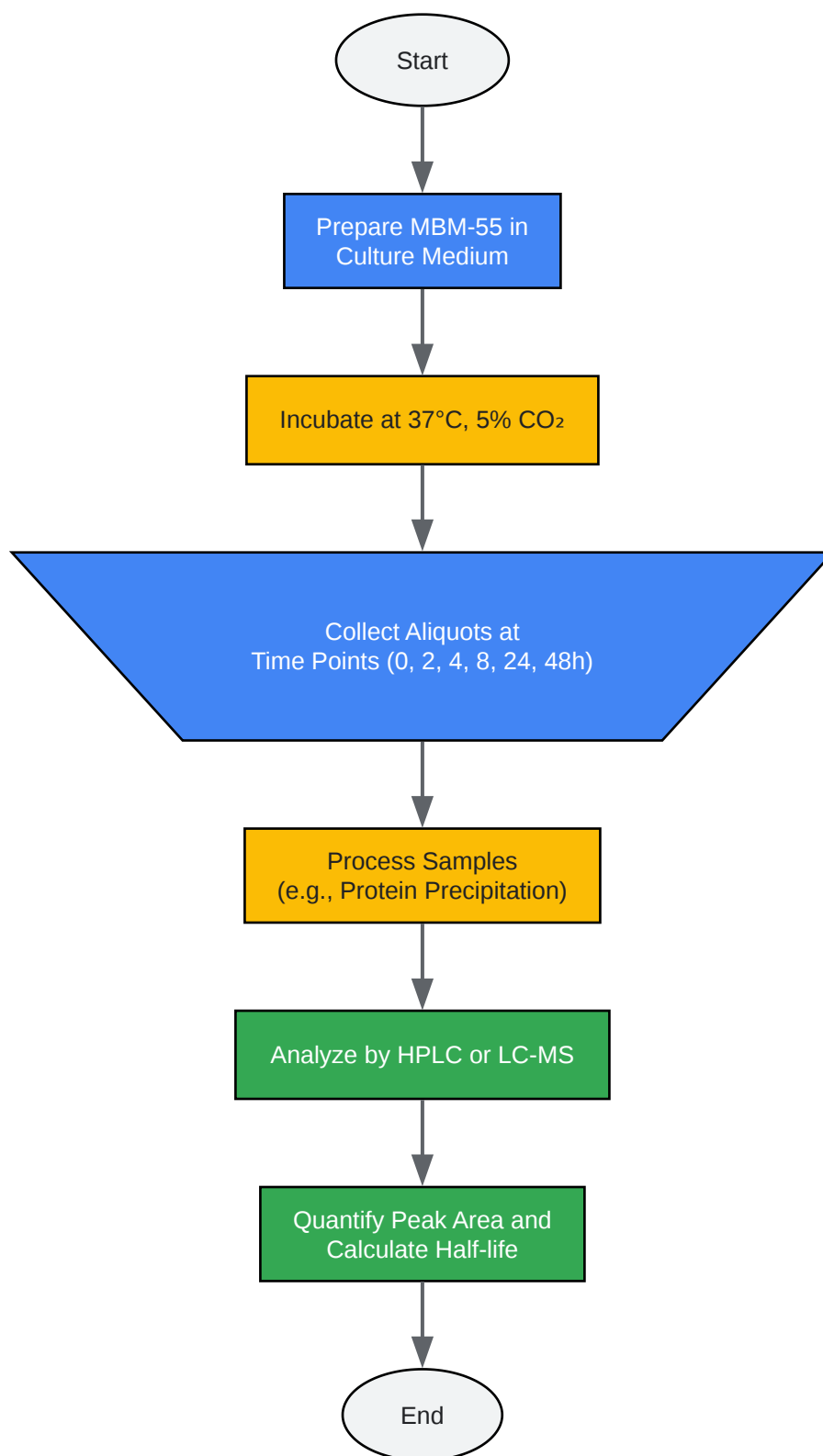

[Click to download full resolution via product page](#)

Caption: Workflow for determining **MBM-55** stability.

Logical Relationship for Troubleshooting Inconsistent Results

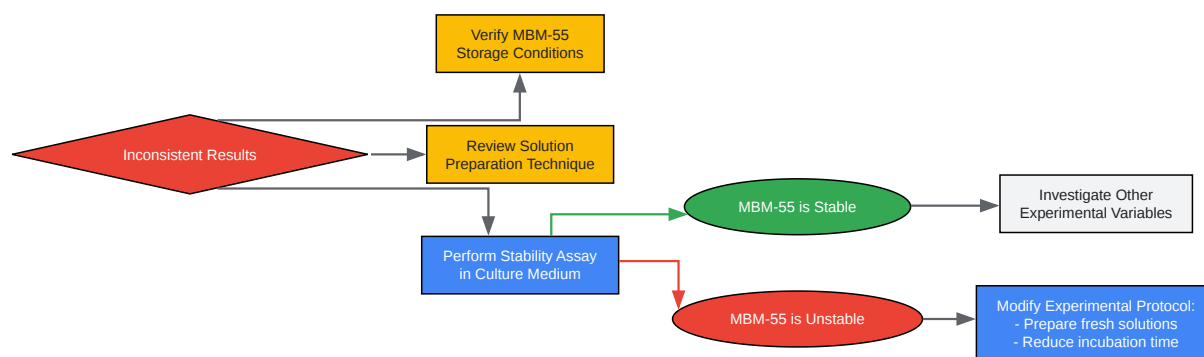

[Click to download full resolution via product page](#)

Caption: Troubleshooting logic for **MBM-55** experiments.

Need Custom Synthesis?

BenchChem offers custom synthesis for rare earth carbides and specific isotopic labeling.

Email: info@benchchem.com or [Request Quote Online](#).

References

- 1. [medkoo.com](https://www.medkoo.com) [medkoo.com]
- 2. [file.glpbio.com](https://www.file.glpbio.com) [file.glpbio.com]
- 3. [glpbio.com](https://www.glpbio.com) [glpbio.com]
- To cite this document: BenchChem. [improving MBM-55 stability in culture media]. BenchChem, [2026]. [Online PDF]. Available at: [<https://www.benchchem.com/product/b10821444/docs#improving-mbm-55-stability-in-culture-media>]

Disclaimer & Data Validity:

The information provided in this document is for Research Use Only (RUO) and is strictly not intended for diagnostic or therapeutic procedures. While BenchChem strives to provide accurate protocols, we make no warranties, express or implied, regarding the fitness of this product for every specific experimental setup.

Technical Support: The protocols provided are for reference purposes. Unsure if this reagent suits your experiment?

Need Industrial/Bulk Grade? [Request Custom Synthesis Quote](#)

BenchChem

Our mission is to be the trusted global source of essential and advanced chemicals, empowering scientists and researchers to drive progress in science and industry.

Contact

Address: 3281 E Guasti Rd
Ontario, CA 91761, United States
Phone: (601) 213-4426
Email: info@benchchem.com

[Contact our Ph.D. Support Team for a compatibility check](#)