

# YX-2-107 Application Notes and Protocols for In Vivo Mouse Models

**Author:** BenchChem Technical Support Team. **Date:** April 2026

## Compound of Interest

Compound Name: YX-2-107  
Cat. No.: B10821831

[Get Quote](#)

For Research Use Only. Not for use in diagnostic procedures.

## Introduction

**YX-2-107** is a potent and selective proteolysis-targeting chimera (PROTAC) that targets Cyclin-Dependent Kinase 6 (CDK6) for degradation.[1][2][3] As a bifunctional molecule, **YX-2-107** recruits an E3 ubiquitin ligase to CDK6, leading to its ubiquitination and subsequent degradation by the proteasome.[4][5][6] This mechanism of action differs from traditional kinase inhibitors, which only block the enzymatic activity of their targets.[5] By inducing the degradation of the entire CDK6 protein, **YX-2-107** can overcome resistance mechanisms associated with kinase inhibitor therapies and address both kinase-dependent and -independent functions of CDK6.[4][5][7]

Preclinical studies have demonstrated the efficacy of **YX-2-107** in mouse models of Philadelphia chromosome-positive acute lymphoblastic leukemia (Ph+ ALL), a hematologic malignancy where CDK6 expression is a key dependency.[1][8][9] These application notes provide a summary of the reported in vivo dosages, pharmacokinetic data, and detailed experimental protocols for the use of **YX-2-107** in mouse models.

## Data Presentation

### Table 1: YX-2-107 In Vivo Efficacy Study Dosages in Mouse Models

| Mouse Model                                     | Dosage           | Administration Route   | Dosing Schedule                                     | Study Duration      | Key Findings   | Reference |
|---|------------------|------------------------|---|---------------------|--|-----------|
| Ph+ ALL Xenograft (NRG-SGM3 mice)               | 150 mg/kg        | Intraperitoneal (i.p.) | Once daily  | 3 consecutive days  | Pharmacologically active in suppressing Ph+ ALL proliferation.[1][2]                       | [1][2]    |
| Ph+ ALL Xenograft (NSG mice)                    | 125 or 150 mg/kg | Intraperitoneal (i.p.) | Once daily or twice daily (half-dose per injection) | 10 consecutive days | As effective as palbociclib in suppressing peripheral blood leukemia burden.[8]            | [8]       |
| TKI-resistant Ph+ ALL Xenograft (NRG-SGM3 mice) | 25 mg/kg         | Intraperitoneal (i.p.) | Twice daily   | 20 consecutive days | More effective than palbociclib in suppressing in vivo growth of TKI-resistant Ph+ ALL.[8] | [8]       |
| TKI-resistant Ph+ ALL                           | 50 mg/kg         | Intraperitoneal (i.p.) | Twice daily   | 20 consecutive days | More effective than  | [8]       |

Xenograft (NRG-SGM3 mice) palpociclib in suppressin g in vivo growth of TKI-resistant Ph+ ALL. [8]

**Table 2: YX-2-107 Pharmacokinetic Profile in Mice**

| Mouse Strain | Dosage   | Adminis tration Route   | Cmax   | Time to Cmax  | Clearan ce                                  | Half-life | Referen ce      |
|--------------|----------|-------------------------|--------|---------------|---|-----------|-----------------|
| C57BL/6j     | 10 mg/kg | Intraperit oneal (i.p.) | 741 nM | Not Specified | Cleared from plasma after 4 hours.[1][2][3] | ~1 hour   | [1][2][3][4][8] |

**Table 3: YX-2-107 Toxicity Evaluation in Mice**

| Mouse Strain | Dosage    | Administra tion Route   | Dosing Schedule | Study Duration       | Observati ons   | Referenc e |
|--------------|-----------|-------------------------|-----------------|----------------------|---|------------|
| C57BL/6j     | 150 mg/kg | Intraperiton eal (i.p.) | Once daily      | 10 consecuti ve days | No signs of distress or weight loss. Did not perturb normal mouse hematopoi esis.[5][8] | [5][8]     |

## Experimental Protocols

### Protocol 1: In Vivo Efficacy Study in a Ph+ ALL Xenograft Mouse Model

Objective: To evaluate the anti-leukemic activity of **YX-2-107** in a patient-derived or cell line-derived Ph+ ALL xenograft mouse model.

Materials:

- **YX-2-107**
- Vehicle control (e.g., Kolliphor/PBS/DMSO 20:70:10 suspension)[8]
- Immunodeficient mice (e.g., NSG or NRG-SGM3)
- Ph+ ALL cells (patient-derived or cell line)
- Sterile PBS
- Syringes and needles for injection
- Calipers for tumor measurement (if applicable)
- Flow cytometer and relevant antibodies (e.g., CD19, CD10) for leukemia burden assessment

Procedure:

- Cell Preparation and Implantation:
  - Culture Ph+ ALL cells under appropriate conditions.
  - Resuspend the required number of cells in sterile PBS.
  - Inject the cells into the tail vein of immunodeficient mice.
- Animal Acclimatization and Monitoring:
  - Allow mice to acclimatize for a specified period.

- Monitor mice regularly for signs of tumor engraftment and overall health.
- Treatment Initiation:
  - Once leukemia is established (e.g., >50% leukemic cells in peripheral blood), randomize mice into treatment and control groups.[8]
  - Prepare **YX-2-107** in the appropriate vehicle at the desired concentration.
  - Administer **YX-2-107** or vehicle control via intraperitoneal injection according to the dosing schedule (e.g., 150 mg/kg, once daily).[1][2][8]
- Monitoring Leukemia Burden:
  - Collect peripheral blood samples at regular intervals.
  - Use flow cytometry to determine the percentage of leukemic cells (e.g., CD19+CD10+).[8]
- Endpoint and Tissue Collection:
  - At the end of the study, euthanize mice according to institutional guidelines.
  - Collect bone marrow and peripheral blood for further analysis (e.g., cell cycle analysis, Western blot).[8]

## Protocol 2: Pharmacokinetic Study of YX-2-107 in Mice

Objective: To determine the pharmacokinetic profile of **YX-2-107** in mice.

Materials:

- **YX-2-107**
- Vehicle control
- C57BL/6j mice
- Syringes and needles for injection

- Blood collection supplies (e.g., EDTA tubes)
- Centrifuge
- LC-MS/MS system for bioanalysis

#### Procedure:

- Dosing:
  - Administer a single dose of **YX-2-107** (e.g., 10 mg/kg) via intraperitoneal injection to a cohort of mice.<sup>[1][2][3][8]</sup>
- Blood Sampling:
  - Collect blood samples from a subset of mice at various time points post-injection (e.g., 0, 0.25, 0.5, 1, 2, 4, 6, 8, and 24 hours).
- Plasma Preparation:
  - Centrifuge the blood samples to separate the plasma.
  - Store plasma samples at -80°C until analysis.
- Bioanalysis:
  - Quantify the concentration of **YX-2-107** in the plasma samples using a validated LC-MS/MS method.
- Data Analysis:
  - Calculate key pharmacokinetic parameters such as C<sub>max</sub>, T<sub>max</sub>, AUC, and half-life.

## Visualizations

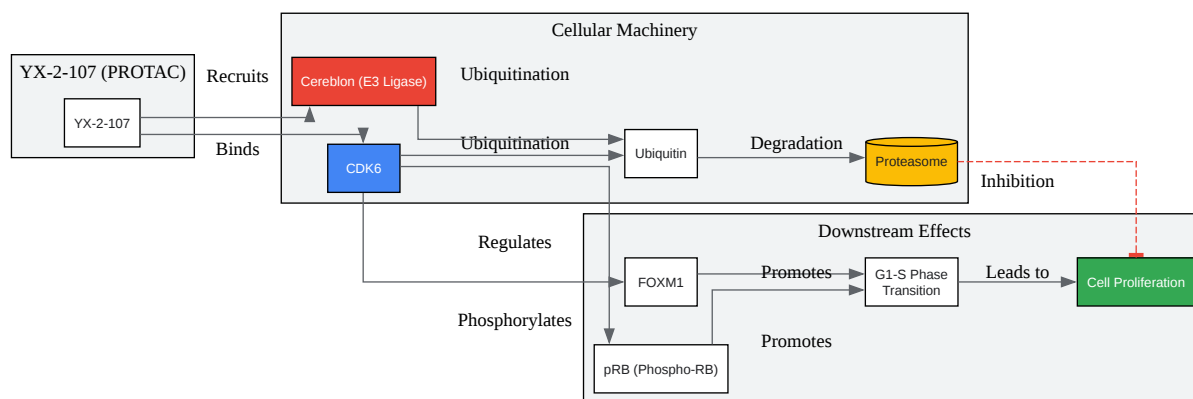

[Click to download full resolution via product page](#)

Caption: Mechanism of action of **YX-2-107** as a CDK6-degrading PROTAC.

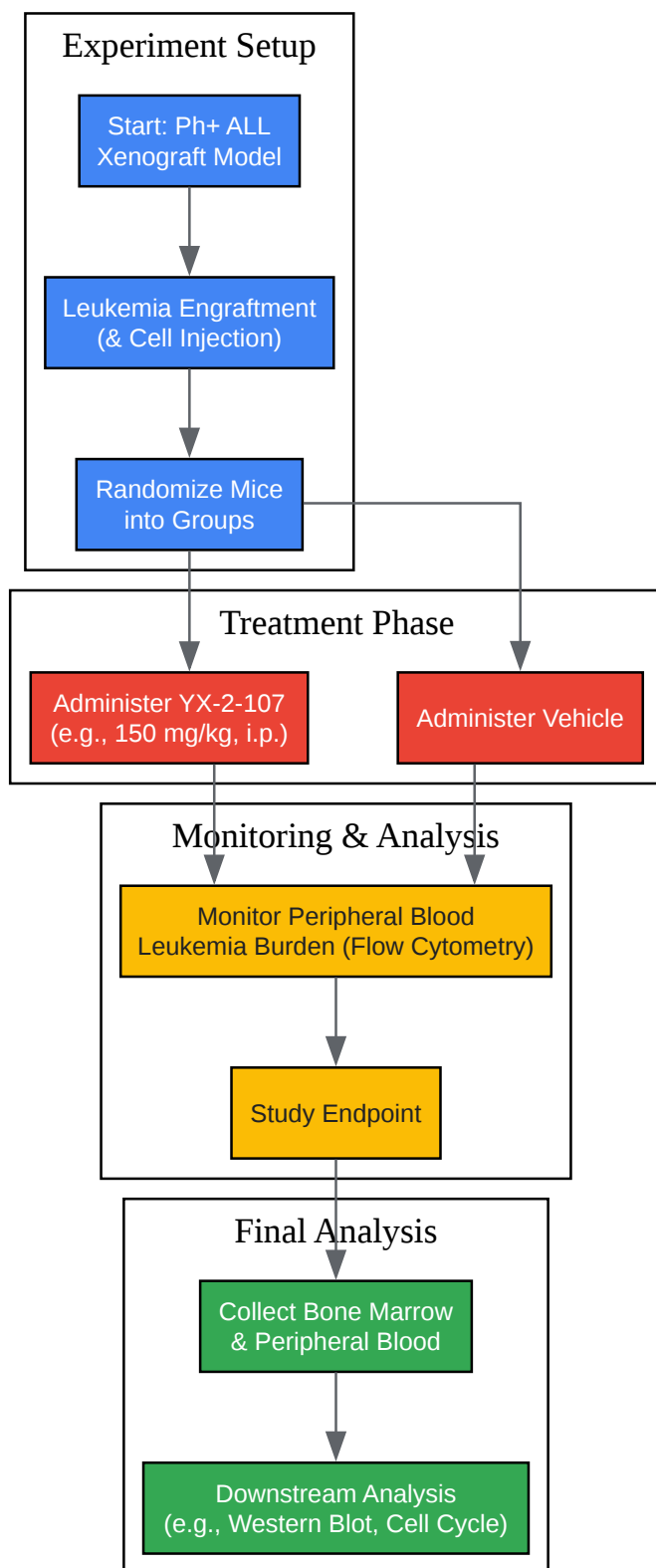

[Click to download full resolution via product page](#)

Caption: General experimental workflow for an in vivo efficacy study.

### Need Custom Synthesis?

BenchChem offers custom synthesis for rare earth carbides and specific isotopic labeling.

Email: [info@benchchem.com](mailto:info@benchchem.com) or [Request Quote Online](#).

## References

- [1. cancer-research-network.com \[cancer-research-network.com\]](https://cancer-research-network.com)
- [2. medchemexpress.com \[medchemexpress.com\]](https://medchemexpress.com)
- [3. YX-2-107 | CDK | TargetMol \[targetmol.com\]](https://targetmol.com)
- [4. Targeting the CDK6 Dependence of Ph+ Acute Lymphoblastic Leukemia - PMC \[pmc.ncbi.nlm.nih.gov\]](https://pubmed.ncbi.nlm.nih.gov/31111111/)
- [5. ashpublications.org \[ashpublications.org\]](https://ashpublications.org)
- [6. researchgate.net \[researchgate.net\]](https://researchgate.net)
- [7. Selective inhibition of Ph-positive ALL cell growth through kinase-dependent and -independent effects by CDK6-specific PROTACs - PubMed \[pubmed.ncbi.nlm.nih.gov\]](https://pubmed.ncbi.nlm.nih.gov/31111111/)
- [8. Selective inhibition of Ph-positive ALL cell growth through kinase-dependent and -independent effects by CDK6-specific PROTACs - PMC \[pmc.ncbi.nlm.nih.gov\]](https://pubmed.ncbi.nlm.nih.gov/31111111/)
- [9. Targeting the CDK6 Dependence of Ph+ Acute Lymphoblastic Leukemia - PubMed \[pubmed.ncbi.nlm.nih.gov\]](https://pubmed.ncbi.nlm.nih.gov/31111111/)
- To cite this document: BenchChem. [YX-2-107 Application Notes and Protocols for In Vivo Mouse Models]. BenchChem, [2026]. [Online PDF]. Available at: [\[https://www.benchchem.com/product/b10821831/docs#yx-2-107-application-notes-and-protocols-for-in-vivo-mouse-models\]](https://www.benchchem.com/product/b10821831/docs#yx-2-107-application-notes-and-protocols-for-in-vivo-mouse-models)

---

### Disclaimer & Data Validity:

The information provided in this document is for Research Use Only (RUO) and is strictly not intended for diagnostic or therapeutic procedures. While BenchChem strives to provide accurate protocols, we make no warranties, express or implied, regarding the fitness of this product for every specific experimental setup.

**Technical Support:** The protocols provided are for reference purposes. Unsure if this reagent suits your experiment?

**Need Industrial/Bulk Grade?** [Request Custom Synthesis Quote](#)

## BenchChem

Our mission is to be the trusted global source of essential and advanced chemicals, empowering scientists and researchers to drive progress in science and industry.

### Contact

Address: 3281 E Guasti Rd  
Ontario, CA 91761, United States  
Phone: (601) 213-4426  
Email: [info@benchchem.com](mailto:info@benchchem.com)

[Contact our Ph.D. Support Team for a compatibility check](#)