

# Technical Support Center: Troubleshooting KB02-JQ1 Experiments

**Author:** BenchChem Technical Support Team. **Date:** April 2026

## Compound of Interest

Compound Name: KB02-JQ1

Cat. No.: B10821872

[Get Quote](#)

This guide provides troubleshooting advice and answers to frequently asked questions for researchers using **KB02-JQ1**, a selective PROTAC (Proteolysis Targeting Chimera) designed to induce the degradation of the BRD4 protein. If you are not observing the expected activity of **KB02-JQ1** in your cell line, this resource can help you identify potential causes and find solutions.

## Frequently Asked Questions (FAQs)

### Q1: What is KB02-JQ1 and how does it work?

**KB02-JQ1** is a PROTAC that functions as a "molecular glue" to induce the degradation of the bromodomain-containing protein 4 (BRD4).<sup>[1][2][3]</sup> It is a bifunctional molecule composed of:

- JQ1: A potent inhibitor that binds to the bromodomain of BRD4.<sup>[4][5][6]</sup>
- KB02: A ligand that covalently modifies and recruits the DCAF16 E3 ubiquitin ligase.<sup>[1][4]</sup>

By simultaneously binding to BRD4 and DCAF16, **KB02-JQ1** brings the target protein into close proximity with the E3 ligase, leading to the ubiquitination of BRD4 and its subsequent

degradation by the proteasome.[4] This action is highly selective for BRD4, with no significant degradation of BRD2 or BRD3 observed.[1][2][4][7]

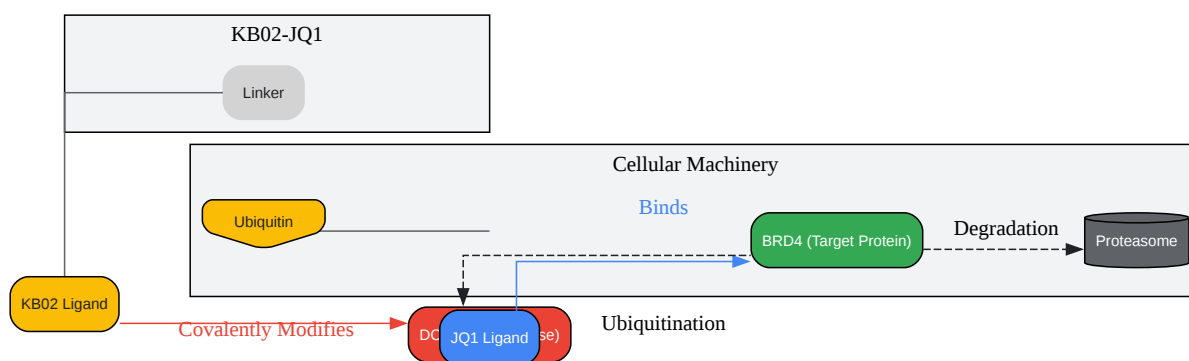

[Click to download full resolution via product page](#)

**Figure 1:** Mechanism of action for **KB02-JQ1**.

## Q2: I'm not seeing any BRD4 degradation. What is the most common reason for **KB02-JQ1** not working?

The most critical factor for **KB02-JQ1** activity is the presence of its specific E3 ligase, DCAF16. The DCAF16 protein is highly conserved across mammals but is notably absent in rodents (e.g., mice, rats).[4] Therefore, **KB02-JQ1** will not be effective in cell lines derived from rodent species.

### Troubleshooting Steps:

- Verify the species of your cell line. If it is of mouse or rat origin, **KB02-JQ1** is not the appropriate tool.
- Confirm DCAF16 expression. If you are using a non-rodent cell line but still observe no activity, verify the expression of DCAF16 via Western blot or qPCR. Low or absent DCAF16 levels will prevent **KB02-JQ1**-mediated degradation.

## Troubleshooting Guide

If you have confirmed your cell line is from an appropriate species and expresses DCAF16, consider the following potential issues:

### Issue 1: Compound Integrity and Handling

Improper storage or handling can lead to the degradation of **KB02-JQ1**.

Storage Condition	Recommended Duration
Stock Solution (-80°C)	Up to 6 months[1]
Stock Solution (-20°C)	Up to 1 month[1]
Working Solution	Prepare fresh for each experiment[1][8]

Recommendations:

- Aliquot the stock solution upon receipt to minimize freeze-thaw cycles.
- Ensure the compound is fully dissolved in an appropriate solvent like DMSO before diluting it in culture medium.[1] If precipitation is observed, gentle warming or sonication may be necessary.[1][8]

### Issue 2: Experimental Parameters

Suboptimal experimental conditions can result in a lack of observable BRD4 degradation.

Parameter	Recommended Range	Notes
Concentration	5 - 40 $\mu$ M	Activity is concentration-dependent. A dose-response experiment is recommended. [1][4]
Incubation Time	24 hours	This is a standard time point used in initial characterization studies.[1][4]

Recommendations:

- Perform a dose-response curve to determine the optimal concentration for your cell line.
- Conduct a time-course experiment (e.g., 6, 12, 24, 48 hours) to identify the optimal treatment duration.

## Issue 3: Cellular Machinery and Pathways

The efficacy of **KB02-JQ1** depends on a functional ubiquitin-proteasome system.

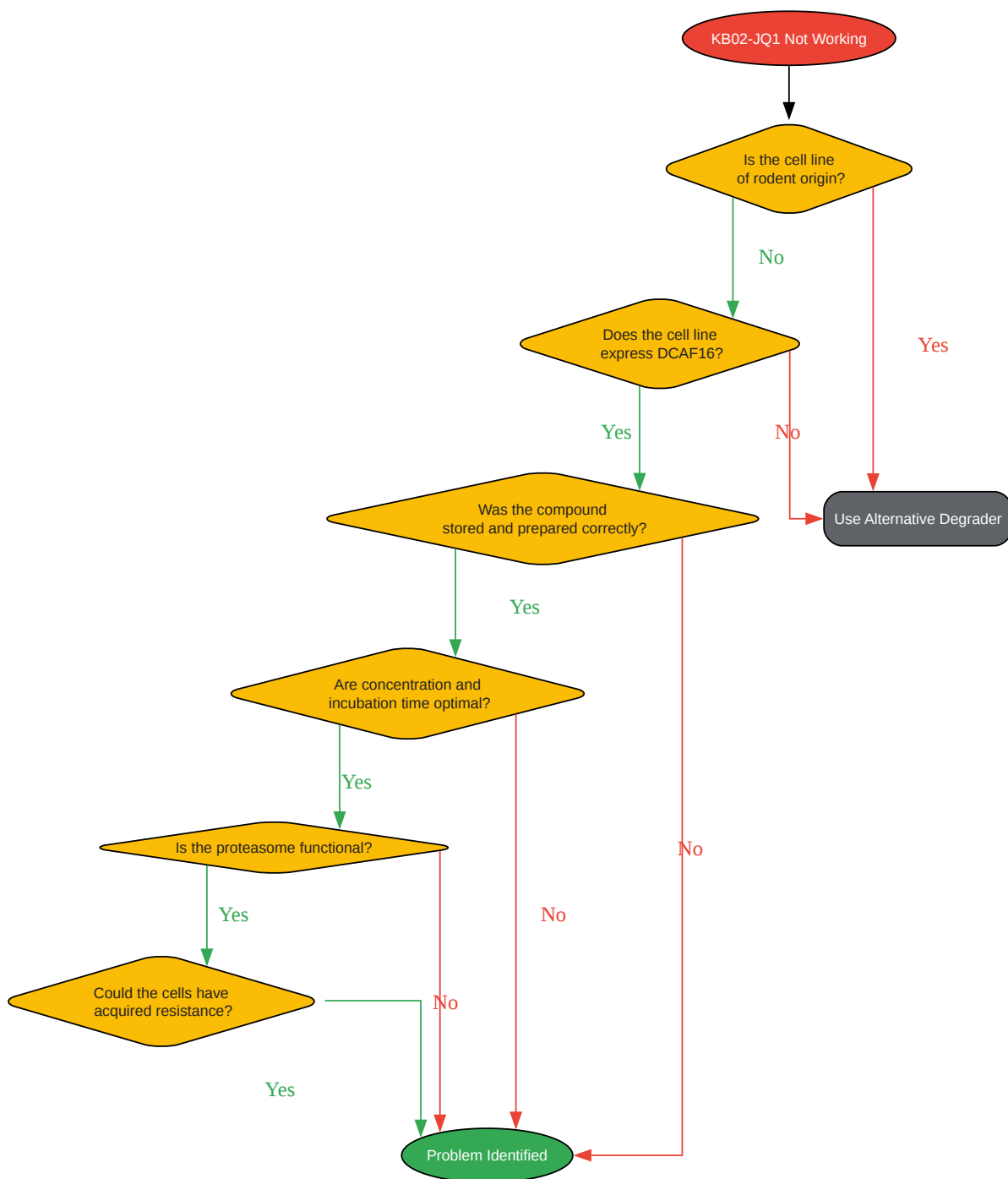

[Click to download full resolution via product page](#)

**Figure 2:** A logical workflow for troubleshooting **KB02-JQ1** experiments.

## Recommendations:

- **Positive Control:** To confirm that the proteasome is active in your cells, use a known proteasome inhibitor like MG132. Pre-treatment with MG132 should block the degradation of BRD4 by **KB02-JQ1**.[\[4\]](#)[\[9\]](#)
- **Resistance Pathways:** Acquired resistance to BET inhibitors like JQ1 can be mediated by the activation of survival pathways, such as the PI3K/AKT pathway.[\[10\]](#) If your cells have been cultured for long periods or have been previously exposed to other BET inhibitors, they may have developed resistance.[\[11\]](#)

## Key Experimental Protocols

### Protocol 1: Western Blot for BRD4 Degradation

This protocol is designed to assess the level of BRD4 protein following treatment with **KB02-JQ1**.

- **Cell Seeding:** Plate your cells at a density that will result in 70-80% confluency at the time of harvest.
- **Treatment:** The following day, treat the cells with a range of **KB02-JQ1** concentrations (e.g., 0, 5, 10, 20, 40  $\mu$ M) for 24 hours.[\[1\]](#) Include a DMSO-treated vehicle control.
- **Cell Lysis:** Wash the cells with ice-cold PBS and lyse them in RIPA buffer supplemented with protease and phosphatase inhibitors.
- **Protein Quantification:** Determine the protein concentration of each lysate using a BCA assay.
- **SDS-PAGE and Transfer:** Load equal amounts of protein (e.g., 20-30  $\mu$ g) onto an SDS-PAGE gel, run the gel, and transfer the proteins to a PVDF membrane.
- **Immunoblotting:**
  - Block the membrane with 5% non-fat milk or BSA in TBST for 1 hour at room temperature.
  - Incubate with a primary antibody against BRD4 overnight at 4°C.

- Incubate with a primary antibody against a loading control (e.g., GAPDH,  $\beta$ -actin) to ensure equal protein loading.
- Wash the membrane and incubate with an appropriate HRP-conjugated secondary antibody for 1 hour at room temperature.
- Detection: Visualize the protein bands using an ECL substrate and an imaging system. Quantify the band intensities to determine the relative level of BRD4 degradation.

## Protocol 2: Proteasome Inhibition Control Experiment

This experiment confirms that the observed degradation is proteasome-dependent.

- Pre-treatment: Treat cells with a proteasome inhibitor (e.g., 10  $\mu$ M MG132) or a neddylation inhibitor (e.g., 1  $\mu$ M MLN4924) for 4 hours.[4][9]
- Co-treatment: Add **KB02-JQ1** (at a concentration known to be effective, e.g., 20  $\mu$ M) to the media, while maintaining the presence of the inhibitor.
- Incubation: Incubate for an additional 20 hours.[4][9]
- Analysis: Harvest the cells and perform a Western blot for BRD4 as described in Protocol 1. A functional proteasome-dependent mechanism should show a rescue of BRD4 levels in the inhibitor-treated samples compared to samples treated with **KB02-JQ1** alone.[4][9]

### Need Custom Synthesis?

BenchChem offers custom synthesis for rare earth carbides and specific isotopic labeling.

Email: [info@benchchem.com](mailto:info@benchchem.com) or [Request Quote Online](#).

## References

- 1. [medchemexpress.com](https://www.medchemexpress.com) [medchemexpress.com]
- 2. [KB02-JQ1, 2384184-44-3 | BroadPharm](#) [broadpharm.com]
- 3. [kb02-jq1 — TargetMol Chemicals](#) [targetmol.com]
- 4. [cancer-research-network.com](https://www.cancer-research-network.com) [cancer-research-network.com]

- [5. General mechanism of JQ1 in inhibiting various types of cancer - PMC \[pmc.ncbi.nlm.nih.gov\]](#)
- [6. go.drugbank.com \[go.drugbank.com\]](#)
- [7. apexbt.com \[apexbt.com\]](#)
- [8. medchemexpress.com \[medchemexpress.com\]](#)
- [9. researchgate.net \[researchgate.net\]](#)
- [10. Resistance to epigenetic-targeted therapy engenders tumor cell vulnerabilities associated with enhancer remodeling - PMC \[pmc.ncbi.nlm.nih.gov\]](#)
- [11. Response and resistance to BET bromodomain inhibitors in triple negative breast cancer - PMC \[pmc.ncbi.nlm.nih.gov\]](#)
- To cite this document: BenchChem. [Technical Support Center: Troubleshooting KB02-JQ1 Experiments]. BenchChem, [2026]. [Online PDF]. Available at: [\[https://www.benchchem.com/product/b10821872/docs#technical-support-center-troubleshooting-kb02-jq1-experiments\]](https://www.benchchem.com/product/b10821872/docs#technical-support-center-troubleshooting-kb02-jq1-experiments)

---

### Disclaimer & Data Validity:

The information provided in this document is for Research Use Only (RUO) and is strictly not intended for diagnostic or therapeutic procedures. While BenchChem strives to provide accurate protocols, we make no warranties, express or implied, regarding the fitness of this product for every specific experimental setup.

**Technical Support:** The protocols provided are for reference purposes. Unsure if this reagent suits your experiment?

**Need Industrial/Bulk Grade?** [Request Custom Synthesis Quote](#)

## BenchChem

Our mission is to be the trusted global source of essential and advanced chemicals, empowering scientists and researchers to drive progress in science and industry.

### Contact

Address: 3281 E Guasti Rd  
Ontario, CA 91761, United States  
Phone: (601) 213-4426  
Email: [info@benchchem.com](mailto:info@benchchem.com)

Contact our Ph.D. Support Team for a compatibility check