

How to prevent BI-1915 degradation in long-term experiments

Author: BenchChem Technical Support Team. **Date:** May 2026

Compound of Interest

Compound Name: BI-1915
Cat. No.: B10821688

[Get Quote](#)

Technical Support Center: BI-1915

This technical support center provides researchers, scientists, and drug development professionals with essential information to prevent the degradation of **BI-1915** in long-term experiments.

Troubleshooting Guide

This guide addresses specific issues users might encounter with **BI-1915** during their experiments.

Issue 1: Diminished or inconsistent inhibitor activity over time in a long-term experiment.

- Potential Cause: Degradation of **BI-1915** in aqueous solution.
 - Troubleshooting Steps:
 - pH Monitoring: **BI-1915** contains a carboxamide group, which can be susceptible to hydrolysis at non-neutral pH.^[1] Regularly monitor the pH of your cell culture medium or experimental buffer. Significant shifts in pH can accelerate degradation.

- Temperature Control: Ensure that the experimental temperature is consistently maintained. Elevated temperatures can increase the rate of chemical degradation.[2] For working solutions stored for short periods, refrigeration at 4°C is recommended.[3]
 - Light Protection: Protect your experimental setup from direct light exposure. Amber-colored tubes or plates, or covering the experimental setup with aluminum foil, can prevent photodegradation.[4][5][6]
 - Fresh Media/Inhibitor Replenishment: In long-term cell culture experiments, the stability of the inhibitor in the media is crucial.[7] It is recommended to replace the media with freshly prepared **BI-1915** at regular intervals (e.g., every 24-48 hours) to maintain a consistent effective concentration.[3]
- Potential Cause: Adsorption to plasticware.
 - Troubleshooting Steps:
 - Use of appropriate labware: Consider using low-adhesion plasticware or glass vials for the storage of stock solutions to minimize loss of the compound.[8]
 - Pre-treatment of plates: In some cases, pre-incubating plates with a blocking agent like bovine serum albumin (BSA) can reduce non-specific binding of small molecules.

Issue 2: High variability between replicate experiments.

- Potential Cause: Inconsistent preparation and handling of **BI-1915** stock solutions.
 - Troubleshooting Steps:
 - Proper Stock Solution Preparation: Prepare a high-concentration stock solution in an appropriate solvent like DMSO.[9] Ensure the compound is fully dissolved. Gentle warming or sonication can aid dissolution, but check for temperature sensitivity first.[10]
 - Aliquoting and Storage: Aliquot the stock solution into single-use volumes to avoid repeated freeze-thaw cycles, which can degrade the compound.[10] Store these aliquots at -80°C for long-term stability.[3]

- Consistent Dilution: When preparing working solutions, add the small volume of the concentrated stock directly into the larger volume of the aqueous buffer and mix immediately to prevent precipitation.[9]

Frequently Asked Questions (FAQs)

Q1: What are the primary factors that can cause **BI-1915** degradation in my experiments?

A1: The main factors contributing to the degradation of small molecules like **BI-1915** in experimental settings are temperature, pH, and light exposure.[11] The carboxamide functional group in **BI-1915** makes it potentially susceptible to hydrolysis, especially under non-neutral pH conditions.[1]

Q2: How should I prepare and store my **BI-1915** stock solution to ensure its stability?

A2: It is recommended to prepare a concentrated stock solution (e.g., 10 mM) in a dry, high-quality solvent such as DMSO.[9][12] This stock solution should be aliquoted into small, single-use volumes and stored at -80°C to minimize degradation from repeated freeze-thaw cycles.[3][10] When preparing working solutions, thaw an aliquot and dilute it into your experimental buffer immediately before use.[13]

Q3: How often should I add fresh **BI-1915** to my long-term cell culture?

A3: The frequency of media changes with fresh inhibitor depends on the stability of **BI-1915** in your specific cell culture conditions. For long-term experiments, it is advisable to replace the medium with freshly prepared **BI-1915** every 24 to 48 hours to maintain a stable concentration of the active compound.[3][7]

Q4: Can I store my working solution of **BI-1915** in aqueous buffer?

A4: Storing **BI-1915** in aqueous solutions for extended periods is not recommended due to the risk of hydrolysis.[7] It is best to prepare fresh working solutions from a frozen DMSO stock for each experiment. If short-term storage of a working solution is necessary, it should be kept at 4°C and used as quickly as possible.[3]

Q5: How can I test the stability of **BI-1915** in my specific experimental setup?

A5: To determine the stability of **BI-1915** under your conditions, you can perform a time-course experiment. Incubate **BI-1915** in your experimental medium at the intended temperature and light conditions. At various time points (e.g., 0, 24, 48, 72 hours), take an aliquot and analyze the concentration of the intact compound using an analytical method like High-Performance Liquid Chromatography (HPLC).[7]

Data Presentation

Table 1: Hypothetical Stability of **BI-1915** Under Various Conditions.

Disclaimer: The following data is illustrative and based on general knowledge of small molecule stability. It is highly recommended that researchers perform their own stability studies for **BI-1915** under their specific experimental conditions.

Condition	Storage Time	Estimated Stability	Notes
Stock Solution			
-80°C in anhydrous DMSO	> 1 year	Optimal for long-term storage. Avoid freeze-thaw cycles.[3]	
-20°C in anhydrous DMSO	Several months	Suitable for intermediate-term storage.	
4°C in anhydrous DMSO	< 1 week	Not recommended for long-term storage.	
Working Solution			
37°C in cell culture medium (pH 7.4)	24-48 hours	Frequent replenishment recommended for long-term experiments.[3]	
4°C in aqueous buffer (pH 7.4)	~1 week	Suitable for short-term storage of freshly prepared solutions. [14]	
Room Temperature in aqueous buffer (pH 7.4)	< 24 hours	Prone to degradation; not recommended.[13]	
37°C in acidic (pH < 6.5) or basic (pH > 8.0) buffer	< 24 hours	Potential for accelerated hydrolysis of the carboxamide group.[1]	
Exposure to direct laboratory light	Variable	Photodegradation is possible; protection from light is crucial.[4] [5][6]	

Experimental Protocols

Protocol 1: Preparation of **BI-1915** Stock Solution

- Weighing: Accurately weigh the desired amount of **BI-1915** powder in a sterile microcentrifuge tube.
- Dissolution: Add the calculated volume of anhydrous, cell culture-grade DMSO to achieve the desired stock concentration (e.g., 10 mM).
- Solubilization: Vortex the solution thoroughly until the compound is completely dissolved. Gentle warming (e.g., 37°C water bath) or brief sonication can be used to aid dissolution if necessary, but be cautious of potential heat-induced degradation.[\[10\]](#)
- Aliquoting: Dispense the stock solution into small, single-use, light-protected (amber) vials.
- Storage: Store the aliquots at -80°C.

Protocol 2: Stability Assessment of **BI-1915** in Experimental Medium

- Preparation: Prepare a working solution of **BI-1915** in your experimental medium at the final concentration to be used in your assay.
- Incubation: Aliquot the solution into several sterile, sealed tubes and incubate them under the exact conditions of your long-term experiment (e.g., 37°C, 5% CO₂, protected from light).
- Time Points: At designated time points (e.g., 0, 8, 24, 48, 72 hours), remove one tube and immediately freeze it at -80°C to halt any further degradation.
- Analysis: Once all time points are collected, analyze the concentration of intact **BI-1915** in each sample using a validated analytical method such as HPLC-MS.
- Data Interpretation: Plot the concentration of **BI-1915** as a function of time to determine its stability profile under your experimental conditions.

Visualizations

Cathepsin S Signaling Pathways

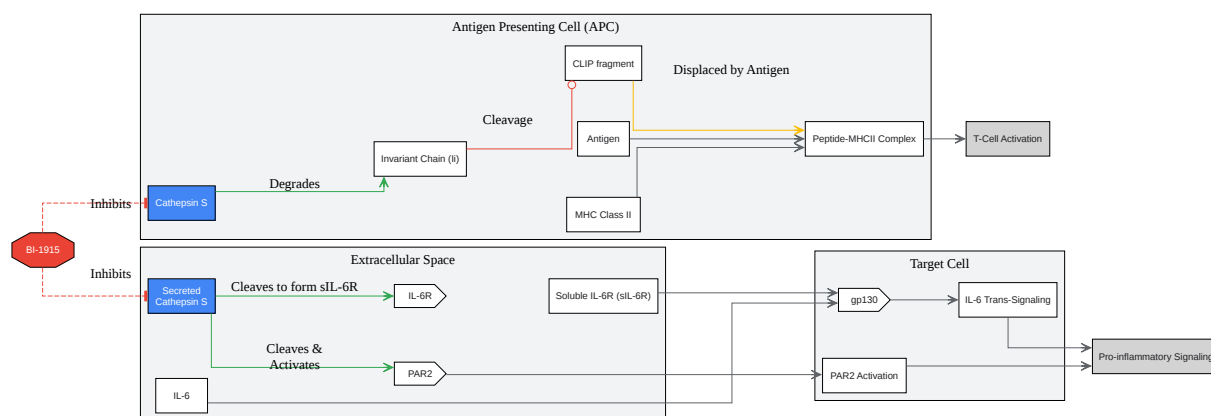

[Click to download full resolution via product page](#)

Caption: **BI-1915** inhibits both intracellular and extracellular Cathepsin S activity.

Experimental Workflow for Long-Term **BI-1915** Treatment

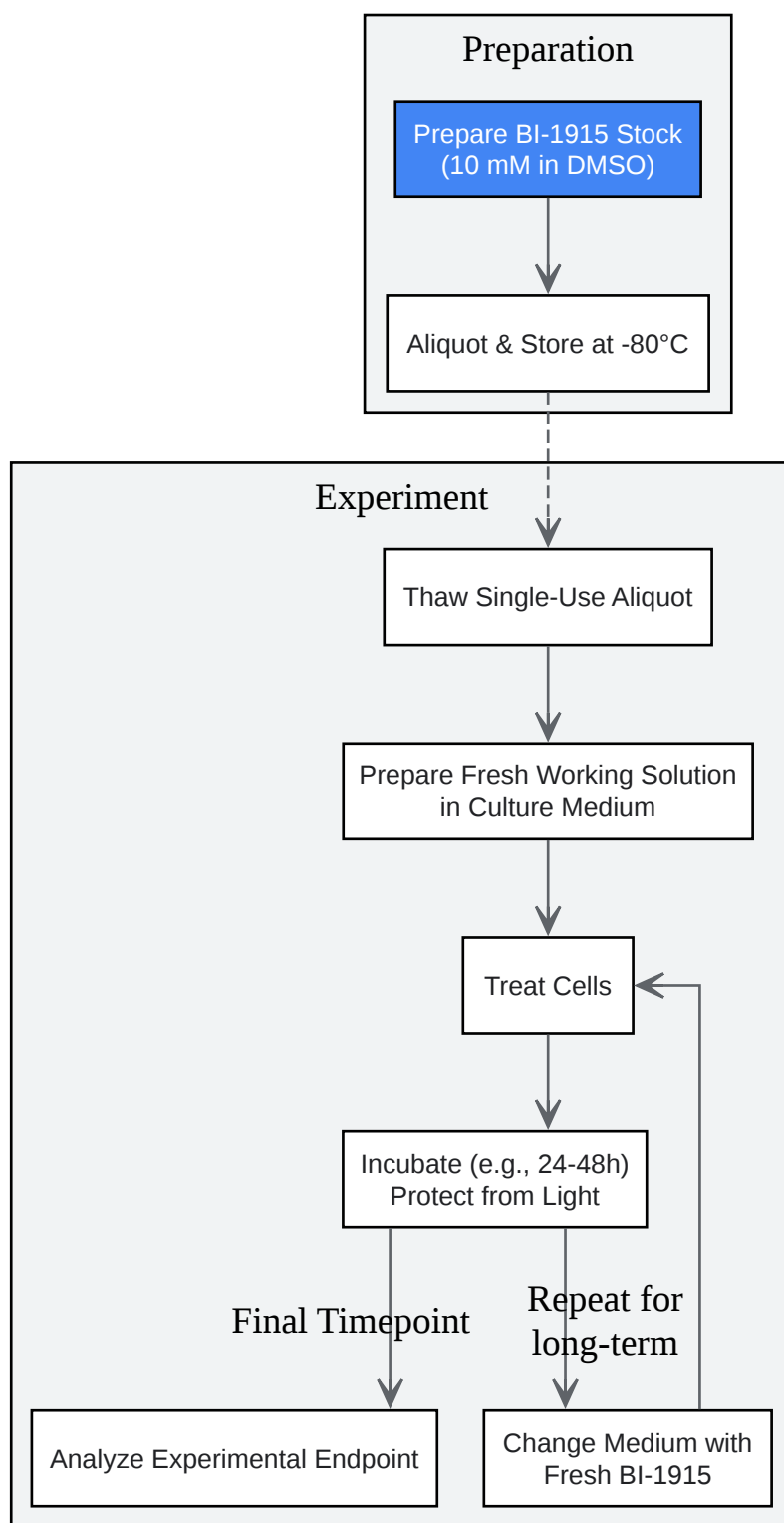

[Click to download full resolution via product page](#)

Caption: Recommended workflow for handling **BI-1915** in long-term cell-based assays.

Troubleshooting Logic for BI-1915 Instability

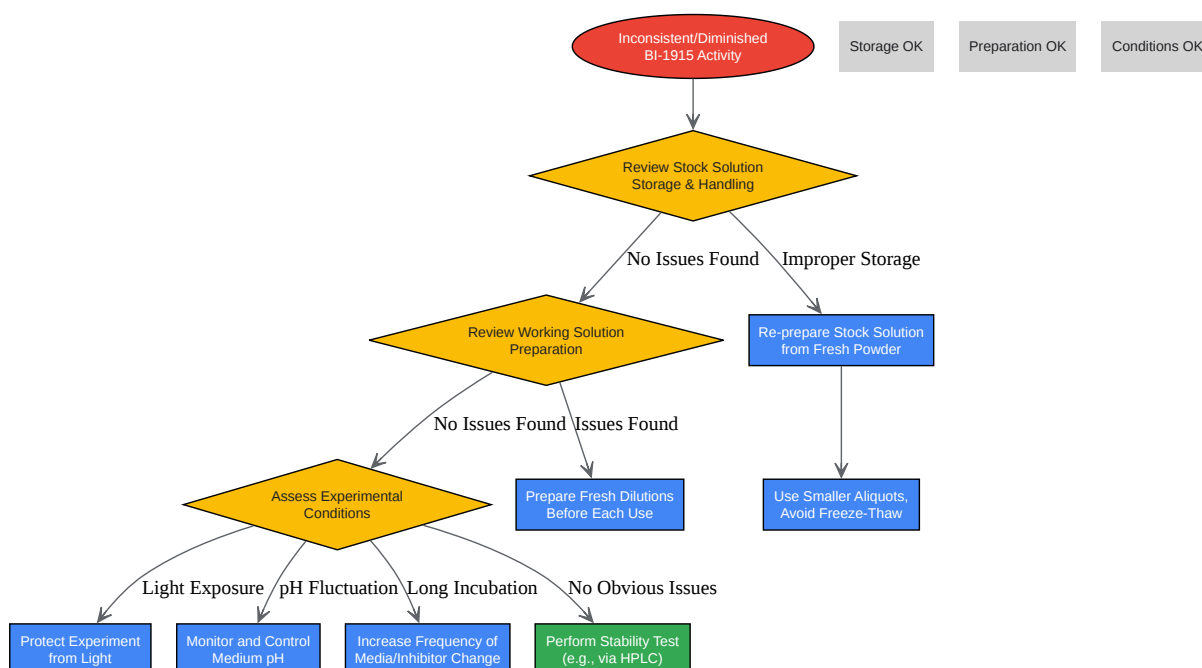

[Click to download full resolution via product page](#)

Caption: A logical approach to troubleshooting inconsistent results with **BI-1915**.

Need Custom Synthesis?

BenchChem offers custom synthesis for rare earth carbides and specific isotopic labeling.

Email: info@benchchem.com or [Request Quote Online](#).

References

- [1. researchgate.net \[researchgate.net\]](#)
- [2. researchgate.net \[researchgate.net\]](#)
- [3. benchchem.com \[benchchem.com\]](#)
- [4. biobostonconsulting.com \[biobostonconsulting.com\]](#)
- [5. ICH guideline for photostability testing: aspects and directions for use - PubMed \[pubmed.ncbi.nlm.nih.gov\]](#)
- [6. FDA Guidelines for Photostability Testing: A Step-by-Step Guide – StabilityStudies.in \[stabilitystudies.in\]](#)
- [7. benchchem.com \[benchchem.com\]](#)
- [8. enfanos.com \[enfanos.com\]](#)
- [9. benchchem.com \[benchchem.com\]](#)
- [10. benchchem.com \[benchchem.com\]](#)
- [11. benchchem.com \[benchchem.com\]](#)
- [12. FAQs on Inhibitor Preparation \[sigmaaldrich.com\]](#)
- [13. What should I consider when using protease inhibitors in the lab? | AAT Bioquest \[aatbio.com\]](#)
- [14. documents.thermofisher.com \[documents.thermofisher.com\]](#)
- [To cite this document: BenchChem. \[How to prevent BI-1915 degradation in long-term experiments\]. BenchChem, \[2026\]. \[Online PDF\]. Available at: \[https://www.benchchem.com/product/b10821688/docs#how-to-prevent-bi-1915-degradation-in-long-term-experiments\]](#)

Disclaimer & Data Validity:

The information provided in this document is for Research Use Only (RUO) and is strictly not intended for diagnostic or therapeutic procedures. While BenchChem strives to provide accurate protocols, we make no warranties, express or implied, regarding the fitness of this product for every specific experimental setup.

Technical Support: The protocols provided are for reference purposes. Unsure if this reagent suits your experiment?

Need Industrial/Bulk Grade? [Request Custom Synthesis Quote](#)

BenchChem

Our mission is to be the trusted global source of essential and advanced chemicals, empowering scientists and researchers to drive progress in science and industry.

Contact

Address: 3281 E Guasti Rd
Ontario, CA 91761, United States
Phone: (601) 213-4426
Email: info@benchchem.com

[Contact our Ph.D. Support Team for a compatibility check](#)