

BI-0115 Technical Support Center: Troubleshooting and FAQs

Author: BenchChem Technical Support Team. **Date:** April 2026

Compound of Interest

Compound Name: BI-0115
Cat. No.: B10821675

[Get Quote](#)

This technical support center provides researchers, scientists, and drug development professionals with guidance on the potential non-specific effects of **BI-0115**, a selective inhibitor of the Lectin-like oxidized LDL receptor-1 (LOX-1). The following information addresses common questions and troubleshooting scenarios that may arise during experiments.

Frequently Asked Questions (FAQs)

Q1: What is the known selectivity profile of **BI-0115**?

A1: **BI-0115** is a highly selective inhibitor of LOX-1.^{[1][2]} It has been profiled against the scavenger receptor class B type I (SR-BI), an alternative scavenger receptor with low structural homology to LOX-1, and showed no activity up to a concentration of 100 μM .^{[1][2]} Furthermore, **BI-0115** has a clean profile in the Eurofins Safety Panel 44™ and does not inhibit the hERG channel ($\text{IC}_{50} > 10 \mu\text{M}$).^{[1][2]}

Q2: Are there any known off-target effects of **BI-0115**?

A2: Based on available data, **BI-0115** is considered a highly selective LOX-1 inhibitor. However, it is important to note that the selectivity of **BI-0115** against other paralogues of the

C-type lectin-like family has not been tested.[1][2] Therefore, non-specific effects arising from interactions with other C-type lectins cannot be ruled out.

Q3: What is the mechanism of action of **BI-0115**?

A3: **BI-0115** inhibits LOX-1 by stabilizing a protein-protein interaction that leads to the formation of an inactive receptor tetramer state.[3][4] This unique mechanism of action prevents the binding of oxidized low-density lipoprotein (oxLDL) to the receptor and its subsequent internalization.[1][3][5]

Q4: What is the recommended use for **BI-0115**?

A4: **BI-0115** is primarily recommended as an in vitro tool compound.[1][2] This is due to its moderate solubility and permeability, as well as suboptimal stability in human, rat, and mouse liver microsomes.[1][2]

Q5: What is the purpose of the negative control, BI-1580?

A5: BI-1580 is provided as a negative control for experiments with **BI-0115**. It is structurally related to **BI-0115** but does not show inhibitory activity against LOX-1 (IC₅₀ > 100 μM).[1] Using BI-1580 can help differentiate between LOX-1 specific effects and potential non-specific or compound-related artifacts in your experiments.

Troubleshooting Guide

Issue	Potential Cause	Recommended Action
Unexpected phenotype observed that does not align with known LOX-1 signaling.	Potential off-target effect due to interaction with an untested C-type lectin family member.	1. Confirm the phenotype is absent when using the negative control, BI-1580. 2. Attempt to rescue the phenotype by overexpressing LOX-1. 3. Consider performing a screen to identify potential off-target interactions, if feasible.
Variability in experimental results or lower than expected potency.	Poor solubility of BI-0115 in aqueous buffers.	1. Ensure complete solubilization of the compound in a suitable solvent (e.g., DMSO) before diluting in aqueous media. ^[6] 2. Prepare fresh dilutions for each experiment. 3. Consider the use of a surfactant, if compatible with your assay, to improve solubility.
Inconsistent results in cell-based assays.	Low cell permeability of BI-0115.	1. Increase the incubation time to allow for sufficient compound uptake. 2. Verify the expression levels of LOX-1 in your cell line. 3. Use positive and negative controls to validate assay performance.
Compound appears inactive in the assay.	Degradation of the compound due to microsomal activity in cell cultures.	1. Minimize incubation times where possible. 2. If using primary cells or cell lines with high metabolic activity, consider the stability of BI-0115 in your specific system.

Quantitative Data Summary

Table 1: In Vitro Potency and Selectivity of **BI-0115**

Target/Assay	BI-0115	BI-1580 (Negative Control)
LOX-1 (IC50)	5.4 μ M	>100 μ M
SR-B1 (IC50)	>172 μ M	>100 μ M
SPR (Kd)	4.3 μ M	Not Determined
ITC (Kd)	6.99 μ M	Not Determined
hERG (IC50)	>10 μ M	Not Determined

Data sourced from [opnme.com](#).^[1]

Table 2: Physicochemical Properties of **BI-0115**

Property	Value
Molecular Weight (Da)	287.8
logD @ pH 7.4	3.4
Aqueous Solubility @ pH 7 (μ g/mL)	0.001
Caco-2 Permeability (10^{-6} cm/s)	30
Microsomal Stability (% Remaining)	Human: 65, Rat: >88, Mouse: <88

Data sourced from [opnme.com](#).^[1]

Experimental Protocols

Key Experiment: LOX-1 Cellular Uptake Assay

This protocol is a generalized representation based on the described high-throughput screening assay.^[3]

- Cell Culture: Plate CHO-K1 cells with doxycycline-inducible expression of human LOX-1 in a suitable multi-well plate and allow them to adhere.
- Induction: Induce LOX-1 expression by adding doxycycline to the culture medium and incubate for the desired time.
- Compound Treatment: Add varying concentrations of **BI-0115** (and BI-1580 as a negative control) to the cells and incubate for a predetermined period.
- oxLDL Internalization: Add fluorescently labeled oxLDL (e.g., AF647-oxLDL) to the wells and incubate to allow for cellular uptake.
- Cell Staining and Imaging: Stain the cell nuclei with a suitable dye (e.g., Hoechst 33342). Acquire images using a high-content imaging system.
- Data Analysis: Quantify the amount of internalized fluorescent oxLDL per cell. Plot the percentage of inhibition against the compound concentration and fit the data to a dose-response curve to determine the IC50 value.

Visualizations

LOX-1 Signaling and Inhibition by BI-0115

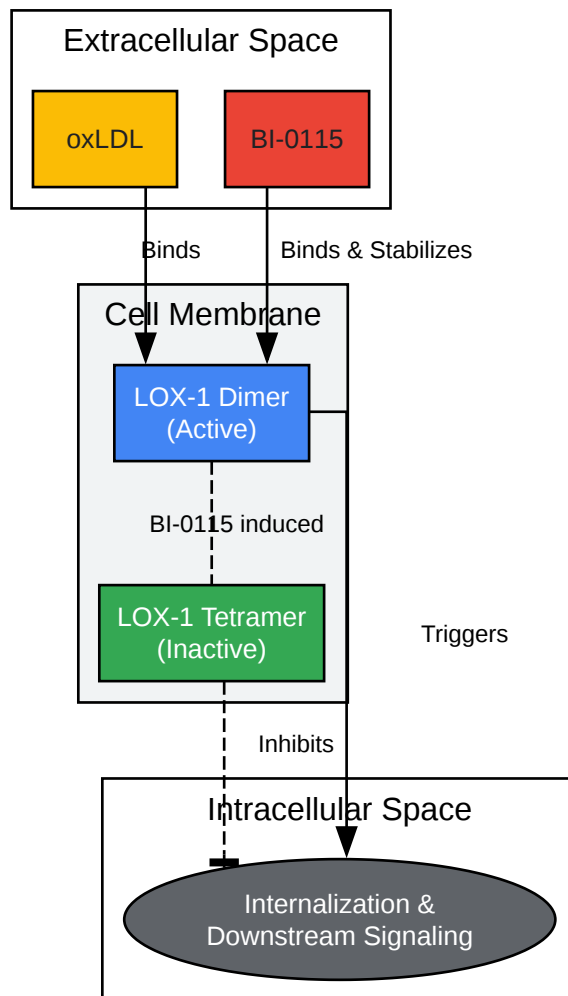

[Click to download full resolution via product page](#)

Caption: Mechanism of **BI-0115** action on the LOX-1 signaling pathway.

Troubleshooting Unexpected Experimental Outcomes

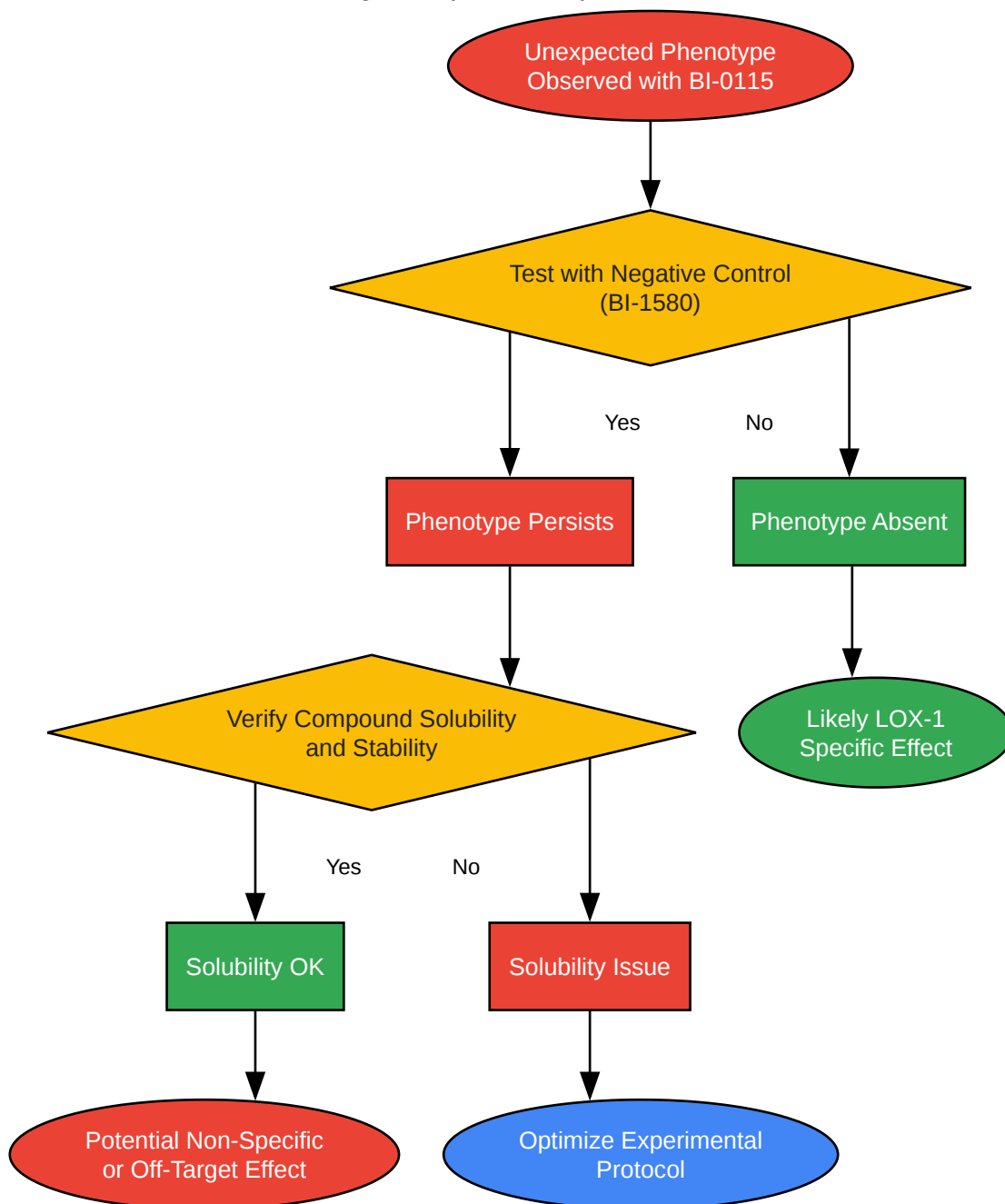

[Click to download full resolution via product page](#)

Caption: A logical workflow for troubleshooting unexpected results with **BI-0115**.

Need Custom Synthesis?

BenchChem offers custom synthesis for rare earth carbides and specific isotopic labeling.

Email: info@benchchem.com or [Request Quote Online](#).

References

- [1. opnme.com \[opnme.com\]](#)
- [2. opnme.com \[opnme.com\]](#)
- [3. researchgate.net \[researchgate.net\]](#)
- [4. discovery.researcher.life \[discovery.researcher.life\]](#)
- [5. medchemexpress.com \[medchemexpress.com\]](#)
- [6. biorxiv.org \[biorxiv.org\]](#)
- To cite this document: BenchChem. [BI-0115 Technical Support Center: Troubleshooting and FAQs]. BenchChem, [2026]. [Online PDF]. Available at: [\[https://www.benchchem.com/product/b10821675/docs#bi-0115-technical-support-center-troubleshooting-and-faqs\]](https://www.benchchem.com/product/b10821675/docs#bi-0115-technical-support-center-troubleshooting-and-faqs)

Disclaimer & Data Validity:

The information provided in this document is for Research Use Only (RUO) and is strictly not intended for diagnostic or therapeutic procedures. While BenchChem strives to provide accurate protocols, we make no warranties, express or implied, regarding the fitness of this product for every specific experimental setup.

Technical Support: The protocols provided are for reference purposes. Unsure if this reagent suits your experiment?

Need Industrial/Bulk Grade? [Request Custom Synthesis Quote](#)

BenchChem

Our mission is to be the trusted global source of essential and advanced chemicals, empowering scientists and researchers to drive progress in science and industry.

Contact

Address: 3281 E Guasti Rd
Ontario, CA 91761, United States
Phone: (601) 213-4426
Email: info@benchchem.com

Contact our Ph.D. Support Team for a compatibility check