

Technical Support Center: Atorvastatin-d5 Signal Suppression

Author: BenchChem Technical Support Team. **Date:** May 2026

Compound of Interest

Compound Name: Atorvastatin-d5 (calcium salt)

Cat. No.: B10820785

[Get Quote](#)

Prepared by: Your Senior Application Scientist

Welcome to the technical support center for bioanalytical assays involving Atorvastatin. This guide is designed for researchers, scientists, and drug development professionals encountering challenges with Atorvastatin-d5 internal standard (IS) signal suppression during LC-MS/MS analysis. Unreliable IS response is a critical issue that can compromise the accuracy, precision, and overall validity of pharmacokinetic and bioequivalence studies.

This document provides in-depth, experience-driven troubleshooting guides and FAQs to help you diagnose the root cause of signal suppression and implement effective solutions.

Section 1: Foundational FAQs

Q1: What is internal standard signal suppression and why is it a critical problem?

A: Internal standard signal suppression is a specific form of a phenomenon known as the "matrix effect," which frequently occurs in liquid chromatography-mass spectrometry (LC-MS). [1] It refers to the reduction in the ionization efficiency of your internal standard (Atorvastatin-d5) in the mass spectrometer's ion source due to the presence of co-eluting, interfering

compounds from the sample matrix (e.g., plasma, serum).[2][3] These interferences compete with your IS for the available charge in the ion source, leading to a diminished signal.[4]

This is a critical problem because the fundamental assumption of using an internal standard is that it will behave identically to the analyte (Atorvastatin) and that any variations during sample preparation or injection will be mirrored in both signals, keeping their ratio constant. When the IS signal is suppressed inconsistently, this core assumption is violated, leading to:

- **Inaccurate Quantification:** The analyte/IS ratio is skewed, causing over or underestimation of the analyte concentration.
- **Poor Precision and Reproducibility:** Variability in the matrix from sample to sample (e.g., different patient plasma) can cause different degrees of suppression, leading to scattered and unreliable results.[1]
- **Failure to Meet Regulatory Standards:** Bioanalytical method validation guidelines from bodies like the U.S. Food and Drug Administration (FDA) require a thorough evaluation and mitigation of matrix effects to ensure data integrity.[1]

Q2: My Atorvastatin-d5 signal is low or variable across my analytical batch. What are the most common culprits?

A: An unstable Atorvastatin-d5 signal is a classic and solvable challenge in bioanalysis. The causes can be grouped into three main categories. The key to efficient troubleshooting is to investigate them systematically, starting from the most likely cause.

- **Matrix Effects (Most Common):** Endogenous components from your biological sample are co-eluting with the Atorvastatin-d5 and suppressing its ionization. The most notorious offenders in plasma are phospholipids.[5][6][7][8]
- **Internal Standard Integrity:** The issue may lie with the IS itself. This can include chemical instability, incorrect concentration, or, specifically for deuterated standards, the back-exchange of deuterium atoms for hydrogen.[9][10]
- **LC-MS/MS System Issues:** Problems with the instrument, such as a contaminated ion source, a failing column, or an inconsistent autosampler, can manifest as signal instability. [11]

The following workflow provides a logical path for diagnosing the issue.

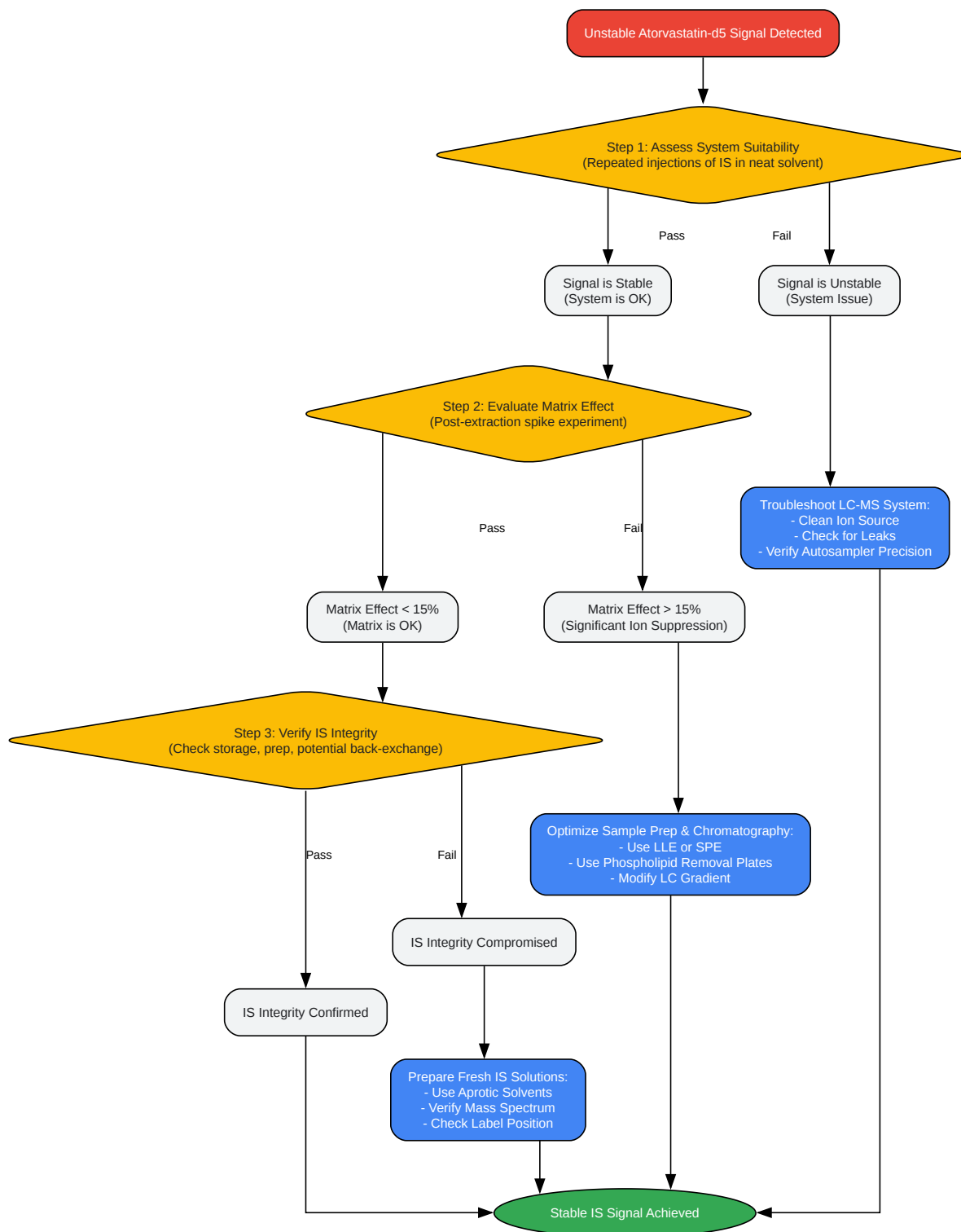

[Click to download full resolution via product page](#)

Caption: Systematic workflow for troubleshooting Atorvastatin-d5 signal suppression.

Section 2: Troubleshooting Guide: Matrix Effects

Q3: How do I definitively determine if matrix effects are causing the suppression of my Atorvastatin-d5 signal?

A: You need to perform an experiment designed to isolate the influence of the matrix. The most direct and widely accepted method is the post-extraction spike analysis.^[12] The logic is to compare the IS signal in a "clean" solution (neat solvent) versus its signal in a solution containing extracted matrix components. A significant difference between the two points directly to matrix-induced suppression or enhancement.

The experiment involves preparing three sets of samples:

- Set A (Neat Solution): Atorvastatin-d5 spiked into the final reconstitution solvent. This is your baseline 100% response.
- Set B (Post-Extraction Spike): Blank biological matrix (e.g., human plasma) is taken through the entire extraction procedure (protein precipitation, LLE, or SPE). The Atorvastatin-d5 is spiked into the final, clean extract. This sample contains all the co-extracted matrix components.
- Set C (Pre-Extraction Spike): This is your typical QC sample, where the Atorvastatin-d5 is spiked into the matrix before extraction. This set is used to determine recovery.

By comparing the peak area of the IS in Set B to Set A, you can calculate the matrix effect.

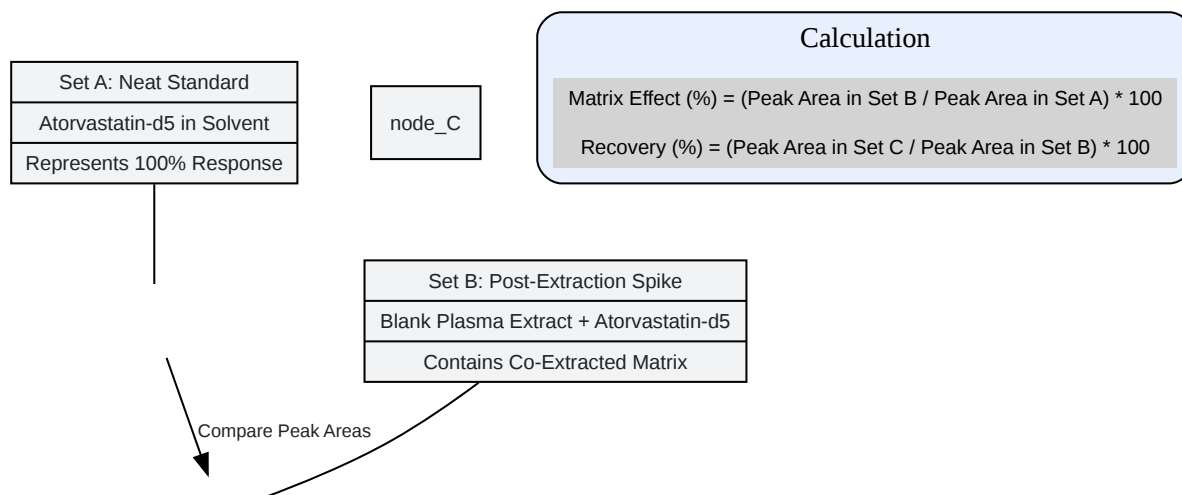

[Click to download full resolution via product page](#)

Caption: Experimental design for quantifying matrix effect and recovery.

Q4: What is a step-by-step protocol to quantitatively assess the matrix effect, and how do I interpret the results?

A: This protocol provides a robust way to measure matrix effects using samples prepared from at least six different sources of blank matrix to assess variability.

Experimental Protocol: Quantitative Matrix Effect Assessment

- Prepare Solutions:
 - Prepare a stock solution of Atorvastatin-d5 in a suitable organic solvent (e.g., Methanol).
 - Prepare a working solution by diluting the stock to the concentration used in your analytical method.
- Prepare Sample Sets (n=6 for each):

- Set A (Neat Standard): In an autosampler vial, add your final reconstitution solvent (e.g., 100 µL of 50:50 Acetonitrile:Water) and spike with the IS working solution (e.g., 10 µL).
- Set B (Post-Extraction Spike): i. Take six different lots of blank plasma (e.g., 100 µL). ii. Process each through your validated extraction method (e.g., protein precipitation with 300 µL of Acetonitrile). iii. Evaporate the supernatant to dryness and reconstitute in the final solvent (e.g., 100 µL). iv. After reconstitution, spike with the IS working solution (e.g., 10 µL).
- Analysis:
 - Inject all samples from Set A and Set B onto the LC-MS/MS system.
 - Record the peak area for Atorvastatin-d5 for each injection.
- Calculation and Interpretation:
 - Calculate the Matrix Factor (MF) for each of the six lots: $MF = (\text{Mean Peak Area of Set B} / \text{Mean Peak Area of Set A})$
 - Calculate the IS-Normalized Matrix Factor if you are also evaluating the analyte.
 - Calculate the Coefficient of Variation (%CV) of the Matrix Factor across the six lots.

Data Interpretation Table

Matrix Factor (MF)	%CV of MF	Interpretation	Action Required
0.85 - 1.15	< 15%	No significant matrix effect. The method is robust.	Proceed with validation.
< 0.85	< 15%	Consistent Ion Suppression. The IS signal is consistently lowered by the matrix. While a stable isotope-labeled IS can often compensate for this, significant suppression can harm sensitivity.[13]	Consider optimizing sample cleanup to improve the Lower Limit of Quantification (LLOQ).
> 1.15	< 15%	Consistent Ion Enhancement. The IS signal is consistently increased by the matrix.	Proceed with caution. Ensure the IS tracks the analyte enhancement perfectly.
Any value	> 15%	Variable Matrix Effect. This is the most problematic scenario. It indicates that the degree of suppression or enhancement varies between different sources of matrix, making reliable quantification impossible.	Method redesign is necessary. Focus on improving sample cleanup and/or chromatographic separation.

Acceptable ranges are based on common industry practice and regulatory expectations.

Q5: My results show significant ion suppression from phospholipids. How can I mitigate this?

A: Phospholipids are a major source of matrix effects in plasma and are notoriously difficult to remove with simple protein precipitation.[\[5\]](#)[\[6\]](#)[\[14\]](#) Improving your sample preparation is the most effective strategy.[\[13\]](#)[\[15\]](#)

Comparison of Sample Preparation Techniques to Reduce Matrix Effects

Technique	Mechanism	Pros	Cons
Protein Precipitation (PPT)	Proteins are denatured and precipitated with an organic solvent (e.g., Acetonitrile).	Fast, simple, inexpensive.	Poor removal of phospholipids, salts, and other small molecules. Often leads to significant matrix effects.[13][16]
Liquid-Liquid Extraction (LLE)	Analytes are partitioned between two immiscible liquid phases based on polarity.[17][18]	Good at removing non-polar lipids and salts. Can provide a very clean extract.	Can be labor-intensive, requires solvent optimization, may have lower analyte recovery.
Solid-Phase Extraction (SPE)	Analytes are retained on a solid sorbent while interferences are washed away.[15]	Highly selective, excellent at removing phospholipids and salts, leading to very clean extracts and reduced matrix effects.[16][19]	More expensive, requires method development to select the correct sorbent and solvents.
Phospholipid Removal Plates (e.g., HybridSPE®)	Combines protein precipitation with specific removal of phospholipids via a filtration plate.[6][14]	Very effective and targeted removal of phospholipids. Simpler than traditional SPE.[6]	Higher cost per sample than PPT or LLE.
Sample Dilution	The sample is simply diluted with mobile phase.[20]	Very simple, reduces the concentration of all matrix components.	Reduces analyte concentration, potentially compromising sensitivity and the LLOQ.[20]

Recommendation: For Atorvastatin, which is commonly analyzed in plasma, moving from a simple protein precipitation method to Solid-Phase Extraction (SPE) or a dedicated

phospholipid removal plate is the most robust solution for eliminating phospholipid-based ion suppression.[\[6\]](#)[\[14\]](#)[\[16\]](#)

Section 3: Troubleshooting Guide: Internal Standard Integrity

Q7: I've improved my sample cleanup, but my IS signal is still inconsistent. Could the Atorvastatin-d5 standard itself be the problem?

A: Yes, absolutely. While stable isotope-labeled internal standards (SIL-IS) are the gold standard, they are not infallible. Several factors related to the IS itself can lead to signal variability.

- **Chemical Stability:** Atorvastatin can degrade when exposed to heat, light, oxygen, or humidity.[\[21\]](#)[\[22\]](#) Although the deuterated form is generally stable, improper storage or repeated freeze-thaw cycles of stock solutions can lead to degradation. Atorvastatin has been shown to be stable in plasma for at least 24 hours at room temperature and for several months at -20°C or below.[\[23\]](#)
- **Deuterium Back-Exchange:** This is a critical and often overlooked issue. If the deuterium atoms on the Atorvastatin-d5 molecule are located at chemically labile positions (e.g., on a hydroxyl or amine group), they can exchange with hydrogen atoms from the solvent (especially water or protic solvents like methanol) under acidic or basic conditions.[\[9\]](#)[\[10\]](#)[\[24\]](#) This results in a gradual loss of the d5-labeled species and an increase in d4, d3, etc., causing the signal at the d5 mass transition to decrease over time. It is crucial to use an IS where the labels are on stable positions, such as aromatic or aliphatic carbons.[\[25\]](#)
- **Preparation Errors:** Simple errors like incorrect dilution, solvent evaporation, or contamination of the stock solution can lead to an incorrect IS concentration in your samples and cause significant issues.

Q8: How can I check for deuterium back-exchange?

A: You can investigate for back-exchange using the mass spectrometer.

Protocol: Checking for Deuterium Back-Exchange

- Acquire a Full Scan Spectrum: Prepare a fresh, high-concentration solution of your Atorvastatin-d5 standard in the mobile phase. Infuse this solution directly into the mass spectrometer and acquire a full scan (Q1 scan) spectrum.
- Analyze the Isotopic Cluster:
 - Expected Result: You should see a clean, primary peak at the m/z corresponding to $[\text{Atorvastatin-d5+H}]^+$. You will also see smaller isotopic peaks (M+1, M+2) due to the natural abundance of ^{13}C .
 - Sign of Back-Exchange: If you observe significant peaks at m/z values corresponding to $[\text{Atorvastatin-d4+H}]^+$, $[\text{Atorvastatin-d3+H}]^+$, etc., it is a strong indicator that back-exchange is occurring.[\[10\]](#)
- Perform a Stability Study: Store your IS working solution under the same conditions as your analytical samples (e.g., in the autosampler at 10°C for 24 hours). Re-inject the solution and acquire another full scan spectrum. A significant increase in the lower mass peaks over time confirms instability and back-exchange under your analytical conditions.

Q9: What are the best practices for preparing and storing Atorvastatin-d5 solutions to ensure stability?

A: Adhering to strict preparation and storage protocols is essential for maintaining the integrity of your internal standard.

- Solvent Choice: For long-term stock solutions, use a high-purity aprotic solvent like acetonitrile if possible, as it lacks exchangeable protons. If a protic solvent like methanol is required for solubility, ensure it is fresh and stored under inert gas (e.g., argon or nitrogen) to minimize dissolved water and CO_2 .
- Storage Conditions: Store stock solutions in amber glass vials at -20°C or, preferably, -80°C to minimize degradation from light and temperature.[\[16\]](#)[\[18\]](#)
- Working Solutions: Prepare fresh working solutions from the stock solution frequently (e.g., daily or for each new batch). Do not store dilute working solutions for extended periods.

- **Avoid Acidity/Basicity:** If back-exchange is suspected, avoid using strong acids or bases in your stock solution solvent.^[10] Buffer your mobile phases to a neutral or near-neutral pH where Atorvastatin is stable.
- **Documentation:** Keep a detailed log of when stock solutions are prepared and used. Perform periodic checks (e.g., monthly) on the stock solution's purity and concentration.

Section 4: Troubleshooting Guide: LC-MS/MS System Issues

Q10: How do I differentiate between matrix effects and system-level problems?

A: A System Suitability Test (SST) is the best way to confirm your LC-MS/MS is performing correctly before you start analyzing biological samples. This test isolates the instrument's performance from any sample-related variability.

Protocol: System Suitability Test

- **Prepare an SST Sample:** Prepare a sample of Atorvastatin and Atorvastatin-d5 in a clean, neat solvent (e.g., your initial mobile phase composition). The concentration should be around the middle of your calibration curve (mid-QC level).
- **Perform Repeat Injections:** Before running your analytical batch, inject the SST sample 5-6 times consecutively.^[26]
- **Evaluate Performance:**
 - **Peak Area Reproducibility:** The %CV of the peak areas for both the analyte and the IS should be less than 5% (ideally < 2%).
 - **Retention Time Stability:** The retention time should not drift by more than $\pm 2\%$ across the injections.
 - **Peak Shape:** The chromatographic peaks should be symmetrical and free of splitting or excessive tailing.

Interpretation:

- If the SST passes: Your LC-MS/MS system is performing correctly. Any signal instability observed in your analytical batch is almost certainly due to matrix effects or IS integrity issues.[26]
- If the SST fails: There is a problem with the instrument. Do not proceed with the batch. The issue could be a dirty ion source, an aging column, an inconsistent autosampler, or unstable pump flow.[11]

Q11: The SST failed, showing a drifting or decreasing IS signal. What are the signs of ion source contamination and how do I fix it?

A: Ion source contamination is a very common cause of gradual or sudden signal loss, especially when running samples with insufficient cleanup.[11] Non-volatile matrix components, particularly phospholipids and salts, build up on the ion source components (e.g., the capillary, spray shield, and orifice).[8]

Symptoms of a Contaminated Ion Source:

- Gradual decline in signal intensity over the course of an analytical batch.
- Sudden signal loss ("signal crash").
- Increased chemical noise or background.
- Poor peak shape.
- The instrument fails tuning or calibration routines.

Solution: Ion Source Cleaning

The solution is to clean the ion source according to the manufacturer's protocol. This typically involves:

- Venting the instrument.
- Carefully removing the ion source components (capillary, skimmer, lenses, etc.).

- Cleaning the components by sonicating them in a sequence of solvents, typically starting with HPLC-grade water, followed by methanol, and then isopropanol or hexane to remove different types of contaminants.
- Drying the components thoroughly with high-purity nitrogen.
- Reassembling the source, pumping the system down, and re-calibrating.

Preventative Maintenance is Key: Regularly cleaning the ion source (e.g., weekly or monthly, depending on sample throughput and cleanliness) is the best way to prevent unexpected downtime and ensure consistent instrument performance.

References

- Shimadzu Corporation. (n.d.). LC/MS/MS High Sensitivity Bioanalytical Method: Atorvastatin Calcium in Human Plasma. Shimadzu.
- AMSbiopharma. (2025). Optimize LC-MS/MS Sensitivity: Ion Suppression in Bioanalysis.
- ResearchGate. (2025). LC-MS-MS Simultaneous Determination of Atorvastatin and Ezetimibe in Human Plasma.
- Shah, J., et al. (2013). LC–MS–MS Simultaneous Determination of Atorvastatin and Ezetimibe in Human Plasma. *Journal of Chromatographic Science*, Oxford Academic. DOI: 10.1093/chromsci/bmt087. Retrieved from [[Link](#)]
- Kole, P. L., et al. (n.d.). Ion Suppression: A Major Concern in Mass Spectrometry. LCGC International.
- AMSbiopharma. (n.d.). Matrix Effects and Ion Suppression in LC-MS: Essential Strategies for Research.
- SCIEX. (2024). Diagnosing signal instability when processing data in Analyst®, MultiQuant™, or SCIEX OS software.
- Al-Saffar, F. K., et al. (2018). Simultaneous LC-MS/MS analysis of simvastatin, atorvastatin, rosuvastatin and their active metabolites for plasma samples of obese patients underwent gastric bypass surgery. NIH National Library of Medicine. DOI: 10.1016/j.jpba.2018.10.035. Retrieved from [[Link](#)]
- Varga, B., et al. (n.d.). Sensitive, High-Throughput Liquid Chromatography-Tandem Mass Spectrometry Analysis of Atorvastatin and Its Pharmacologically Active Metabolites in Serum for Supporting Precision Pharmacotherapy. PubMed Central. Retrieved from [[Link](#)]

- Wales, T. E., et al. (2025). Comprehensive Internal Standards for Hydrogen–Deuterium Exchange Mass Spectrometry. Analytical Chemistry, ACS Publications. DOI: 10.1021/acs.analchem.0c03914. Retrieved from [[Link](#)]
- van den Broek, I., et al. (n.d.). Innovations and Strategies of Sample Preparation Techniques to Reduce Matrix Effects During LC–MS/MS Bioanalysis. LCGC International.
- Xu, R. N., et al. (2011). Phospholipid-Based Matrix Effects in LC–MS Bioanalysis. Taylor & Francis Online. DOI: 10.1080/19475411.2011.552255. Retrieved from [[Link](#)]
- Zhang, Y., et al. (n.d.). Evaluation Methods for Stability and Analysis of Underlying Causes of Instability in Form I Atorvastatin Calcium Drug Substance. MDPI. Retrieved from [[Link](#)]
- Dai, X., et al. (n.d.). HybridSPE: A novel technique to reduce phospholipid-based matrix effect in LC–ESI-MS Bioanalysis. NIH National Library of Medicine. DOI: 10.1016/j.jchromb.2010.07.031. Retrieved from [[Link](#)]
- ResearchGate. (2018). Abnormal Variations in the Internal Standard Signal in UPLC-MS/MS?. Retrieved from [[Link](#)]
- Gucinski, A. C., et al. (n.d.). Automated extraction of backbone deuteration levels from amide H/2H mass spectrometry experiments. NIH National Library of Medicine. DOI: 10.1110/ps.04943004. Retrieved from [[Link](#)]
- Thermo Fisher Scientific. (n.d.). Ion suppression in Biological Sample Analysis: You May or May Not See It but It's There.
- Carling, R. S., et al. (n.d.). Potential problems with using deuterated internal standards for liquid chromatography-tandem mass spectrometry. ResearchGate. Retrieved from [[Link](#)]
- Liu, G., et al. (2024). Internal standard variability: root cause investigation, parallelism for evaluating trackability and practical considerations. NIH National Library of Medicine. DOI: 10.4155/bio-2023-0211. Retrieved from [[Link](#)]
- da Silva, R. G. C., et al. (n.d.). Compensate for or Minimize Matrix Effects? Strategies for Overcoming Matrix Effects in Liquid Chromatography-Mass Spectrometry Technique: A Tutorial Review. NIH National Library of Medicine. Retrieved from [[Link](#)]

- Crevar-Sakač, M., et al. (2015). LC–MS/MS Method for Quantification of Atorvastatin, o-Hydroxyatorvastatin, p-Hydroxyatorvastatin, and Atorvastatin Lactone. AKJournals. DOI: 10.1556/JPC.28.2015.4.1. Retrieved from [[Link](#)]
- Kumar, V., et al. (n.d.). Stress Degradation Behavior of Atorvastatin Calcium and Development of a Suitable Stability-Indicating LC Method for the Determination of Atorvastatin, its Related Impurities, and its Degradation Products. NIH National Library of Medicine. Retrieved from [[Link](#)]
- Wikipedia. (n.d.). Ion suppression (mass spectrometry). Retrieved from [[Link](#)]
- ResearchGate. (2025). Phospholipid-Based Matrix Effects in LC–MS Bioanalysis | Request PDF. Retrieved from [[Link](#)]
- Resolve Mass Spectrometry. (2025). Deuterated Internal Standards for LC-MS: Selection & Custom Synthesis. YouTube. Retrieved from [[Link](#)]
- ResearchGate. (n.d.). Stability of atorvastatin in human plasma | Download Table. Retrieved from [[Link](#)]
- ResearchGate. (2014). HELP WITH INCONSISTENT AND FLUCTUATING SIGNAL ON LC/MS/MS. Retrieved from [[Link](#)]
- Element Lab Solutions. (n.d.). Hidden Problems in your LCMS data?. Retrieved from [[Link](#)]
- Bioanalysis Zone. (n.d.). Two distinct sample prep approaches to overcome matrix effect in LC/MS of serum or plasma samples. Retrieved from [[Link](#)]
- Stoll, D. R. (2025). Matrix Effects on Quantitation in Liquid Chromatography: Sources and Solutions. Chromatography Online.

Need Custom Synthesis?

BenchChem offers custom synthesis for rare earth carbides and specific isotopic labeling.

Email: info@benchchem.com or [Request Quote Online](#).

Sources

- [1. chromatographyonline.com \[chromatographyonline.com\]](https://www.chromatographyonline.com)
- [2. Optimize LC-MS/MS Sensitivity: Ion Suppression in Bioanalysis | AMSbiopharma \[amsbiopharma.com\]](https://www.amsbiopharma.com)
- [3. Ion suppression \(mass spectrometry\) - Wikipedia \[en.wikipedia.org\]](https://en.wikipedia.org)
- [4. Ion-Suppression & Phospholipid Contamination \[sigmaaldrich.com\]](https://www.sigmaaldrich.com)
- [5. tandfonline.com \[tandfonline.com\]](https://www.tandfonline.com)
- [6. HybridSPE: A novel technique to reduce phospholipid-based matrix effect in LC–ESI-MS Bioanalysis - PMC \[pmc.ncbi.nlm.nih.gov\]](https://pubmed.ncbi.nlm.nih.gov)
- [7. researchgate.net \[researchgate.net\]](https://www.researchgate.net)
- [8. bioanalysis-zone.com \[bioanalysis-zone.com\]](https://www.bioanalysis-zone.com)
- [9. pubs.acs.org \[pubs.acs.org\]](https://pubs.acs.org)
- [10. researchgate.net \[researchgate.net\]](https://www.researchgate.net)
- [11. Diagnosing signal instability when processing data in Analyst®, MultiQuant™, or SCIEX OS software \[sciex.com\]](https://www.sciex.com)
- [12. Simultaneous LC-MS/MS analysis of simvastatin, atorvastatin, rosuvastatin and their active metabolites for plasma samples of obese patients underwent gastric bypass surgery - PMC \[pmc.ncbi.nlm.nih.gov\]](https://pubmed.ncbi.nlm.nih.gov)
- [13. chromatographyonline.com \[chromatographyonline.com\]](https://www.chromatographyonline.com)
- [14. Two Distinct Sample Prep Approaches to Overcome Matrix Effect in LC/MS of Serum or Plasma Samples \[sigmaaldrich.com\]](https://www.sigmaaldrich.com)
- [15. longdom.org \[longdom.org\]](https://www.longdom.org)
- [16. akjournals.com \[akjournals.com\]](https://www.akjournals.com)
- [17. researchgate.net \[researchgate.net\]](https://www.researchgate.net)
- [18. academic.oup.com \[academic.oup.com\]](https://academic.oup.com)
- [19. chromatographyonline.com \[chromatographyonline.com\]](https://www.chromatographyonline.com)
- [20. Compensate for or Minimize Matrix Effects? Strategies for Overcoming Matrix Effects in Liquid Chromatography-Mass Spectrometry Technique: A Tutorial Review - PMC \[pmc.ncbi.nlm.nih.gov\]](https://pubmed.ncbi.nlm.nih.gov)
- [21. mdpi.com \[mdpi.com\]](https://www.mdpi.com)

- [22. Stress Degradation Behavior of Atorvastatin Calcium and Development of a Suitable Stability-Indicating LC Method for the Determination of Atorvastatin, its Related Impurities, and its Degradation Products - PMC \[pmc.ncbi.nlm.nih.gov\]](#)
- [23. researchgate.net \[researchgate.net\]](#)
- [24. Automated extraction of backbone deuteration levels from amide H/2H mass spectrometry experiments - PMC \[pmc.ncbi.nlm.nih.gov\]](#)
- [25. m.youtube.com \[m.youtube.com\]](#)
- [26. researchgate.net \[researchgate.net\]](#)
- To cite this document: BenchChem. [Technical Support Center: Atorvastatin-d5 Signal Suppression]. BenchChem, [2026]. [Online PDF]. Available at: [\[https://www.benchchem.com/product/b10820785/docs#technical-support-center-atorvastatin-d5-signal-suppression\]](https://www.benchchem.com/product/b10820785/docs#technical-support-center-atorvastatin-d5-signal-suppression)

Disclaimer & Data Validity:

The information provided in this document is for Research Use Only (RUO) and is strictly not intended for diagnostic or therapeutic procedures. While BenchChem strives to provide accurate protocols, we make no warranties, express or implied, regarding the fitness of this product for every specific experimental setup.

Technical Support: The protocols provided are for reference purposes. Unsure if this reagent suits your experiment?

Need Industrial/Bulk Grade? [Request Custom Synthesis Quote](#)

BenchChem

Our mission is to be the trusted global source of essential and advanced chemicals, empowering scientists and researchers to drive progress in science and industry.

Contact

Address: 3281 E Guasti Rd
Ontario, CA 91761, United States
Phone: (601) 213-4426
Email: info@benchchem.com

Contact our Ph.D. Support Team for a compatibility check