

Technical Support Center: Overcoming JR14a Variability in Experimental Results

Author: BenchChem Technical Support Team. **Date:** April 2026

Compound of Interest

Compound Name: JR14a
Cat. No.: B10819433

[Get Quote](#)

This technical support center provides troubleshooting guides and frequently asked questions (FAQs) to assist researchers, scientists, and drug development professionals in addressing the experimental variability associated with the C3a receptor modulator, **JR14a**.

Frequently Asked Questions (FAQs)

Q1: What is **JR14a** and what is its primary mechanism of action?

JR14a is a potent small-molecule thiophene compound that acts as a modulator of the human complement C3a receptor (C3aR), a G protein-coupled receptor (GPCR) involved in inflammatory and immune responses.^{[1][2]} While initially reported as a selective antagonist of C3aR, subsequent studies have revealed that **JR14a** can also exhibit agonist activity.^{[3][4][5]} This dual functionality is a primary source of experimental variability.

Q2: Why am I seeing conflicting results (both antagonism and agonism) with **JR14a** in my experiments?

The dual agonist/antagonist behavior of **JR14a** is a key challenge. The observed effect can depend on several factors:

- **Receptor Desensitization:** **JR14a** can act as a potent agonist, leading to rapid C3aR phosphorylation, β -arrestin recruitment, and subsequent receptor internalization and desensitization.[6][7][8] This can result in a state where the receptor is unresponsive to further stimulation by either **JR14a** or the endogenous ligand C3a, giving the appearance of antagonism.
- **Experimental Conditions:** The specific cell type, receptor expression level, incubation time, and the functional assay being used can all influence whether the agonistic or antagonistic properties of **JR14a** are more prominent.
- **Signal Bias:** Like many GPCR modulators, **JR14a** may exhibit biased agonism, preferentially activating one downstream signaling pathway (e.g., G protein activation) over another (e.g., β -arrestin recruitment).

Q3: How should I store and prepare **JR14a** to ensure its stability and activity?

Proper storage and handling are critical for consistent results.

- **Storage:** **JR14a** stock solutions should be stored at -20°C for up to one year or at -80°C for up to two years.[1]
- **Solvents:** **JR14a** is typically dissolved in dimethyl sulfoxide (DMSO) to create a stock solution.[9] For in vivo experiments, various solvent mixtures including PEG300, Tween-80, and saline have been used.[1]
- **Working Solutions:** It is recommended to prepare fresh working solutions for each experiment to avoid degradation and precipitation.[1] If precipitation occurs upon dilution, gentle warming or sonication can be used to aid dissolution.[1]

Q4: What cell lines are commonly used to study **JR14a**'s effects on C3aR?

Several cell lines have been successfully used in **JR14a** research, including:

- **Human Mast Cell Line (LAD2):** For studying degranulation (β -hexosaminidase release).[1][2]
- **Human Monocytic Cell Line (THP-1):** For cAMP and calcium flux assays.[3]

- Human Embryonic Kidney Cells (HEK293): Often used for heterologous expression of C3aR to study specific signaling pathways like cAMP modulation and β -arrestin recruitment.[3]
- Primary Cells: Including human monocyte-derived macrophages and mouse primary brain endothelial cells, have also been used to investigate the effects of **JR14a**. [1][10]

C3aR Signaling Pathway

The complement C3a receptor (C3aR) is a versatile GPCR that can couple to multiple G proteins, primarily $G_{\alpha i}$ and $G_{\alpha q}$, to initiate diverse downstream signaling cascades.

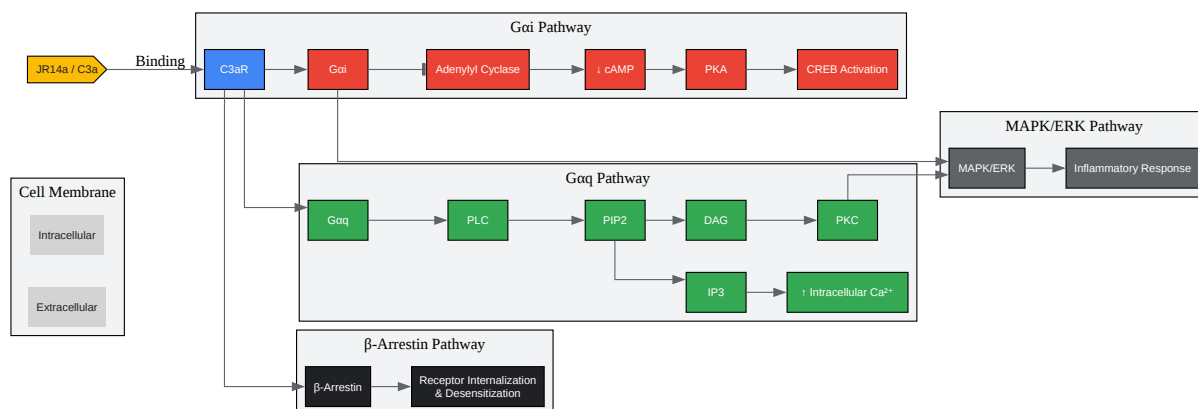

[Click to download full resolution via product page](#)

Caption: C3aR signaling pathways activated by **JR14a**.

Troubleshooting Guides and Experimental Protocols

This section provides detailed troubleshooting guides and standardized protocols for key experiments used to characterize the activity of **JR14a**.

Experimental Workflow Overview

The following diagram outlines a general workflow for characterizing the effects of **JR14a**.

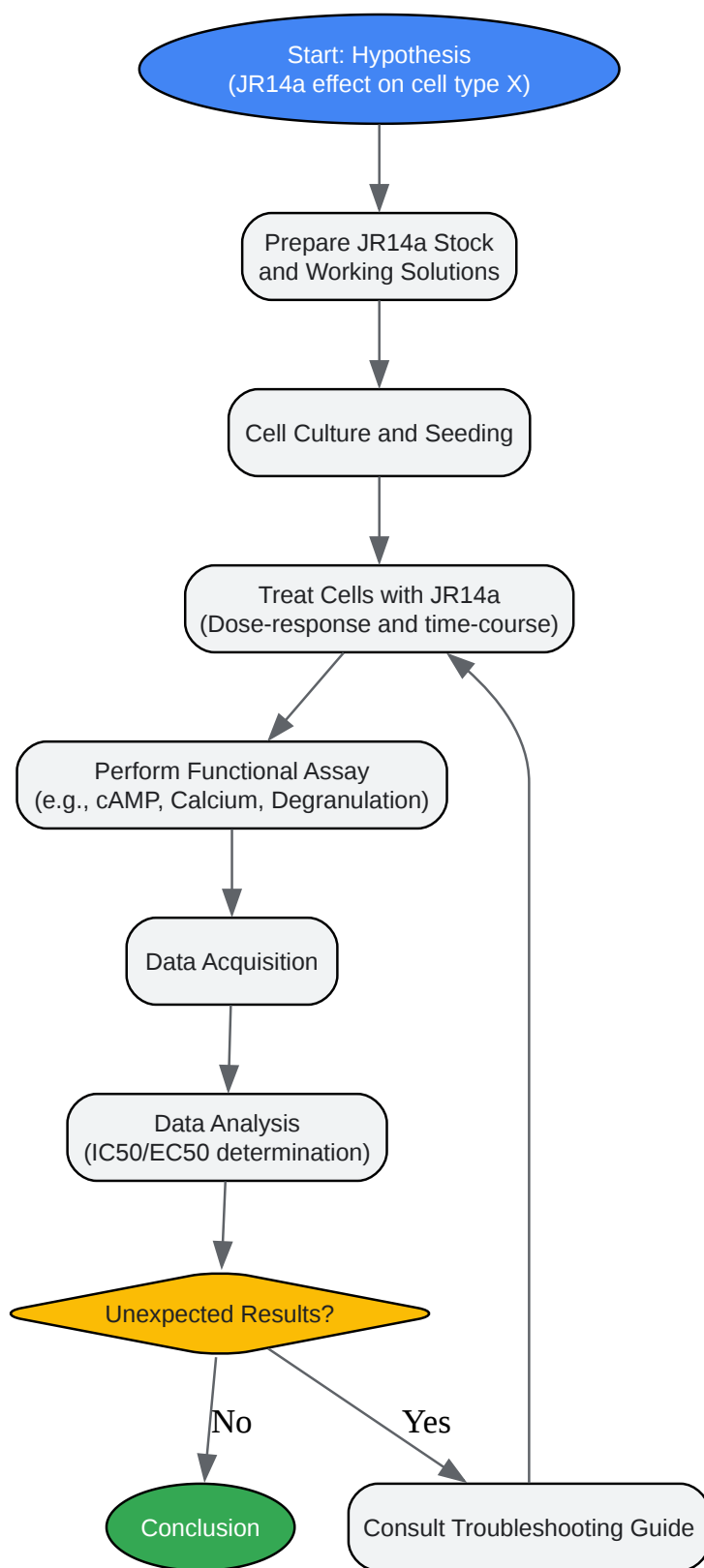

[Click to download full resolution via product page](#)

Caption: General experimental workflow for **JR14a** studies.

Calcium Flux Assay

This assay measures changes in intracellular calcium concentration upon C3aR activation.

Detailed Protocol:

- Cell Preparation:
 - Culture cells (e.g., HEK293-C3aR, THP-1) to 80-90% confluency.
 - Harvest and resuspend cells in a suitable buffer (e.g., HBSS with 20 mM HEPES).
 - Load cells with a calcium-sensitive dye (e.g., Fluo-4 AM or Indo-1 AM) according to the manufacturer's instructions. This typically involves incubation for 30-60 minutes at 37°C.
 - Wash the cells to remove excess dye and resuspend in assay buffer.
- Assay Procedure:
 - Aliquot the dye-loaded cells into a 96-well plate.
 - Use a fluorescence plate reader with an automated injection system.
 - Establish a baseline fluorescence reading for approximately 30 seconds.
 - Inject **JR14a** at various concentrations and continue to measure fluorescence in real-time for at least 2-3 minutes to capture the transient calcium response.
 - Include positive controls (e.g., C3a, ionomycin) and a vehicle control (e.g., DMSO).
- Data Analysis:
 - Calculate the change in fluorescence intensity over baseline.
 - Plot the peak fluorescence response against the **JR14a** concentration.
 - Determine the EC50 value from the dose-response curve.

Troubleshooting Guide: Calcium Flux Assay

Issue	Possible Cause(s)	Suggested Solution(s)
No response to JR14a or C3a	Low C3aR expression; inactive JR14a/C3a; improper dye loading.	Verify C3aR expression via qPCR or Western blot. Use a fresh aliquot of JR14a and C3a. Optimize dye loading concentration and incubation time.
High background signal	Cell death; dye leakage; constitutive receptor activity.	Check cell viability. Ensure gentle handling of cells. Use a lower dye concentration. If high basal activity is suspected, consider using an inverse agonist.
Variable results between replicates	Inconsistent cell numbers; pipetting errors; JR14a precipitation.	Ensure a homogenous cell suspension. Calibrate pipettes. Prepare fresh JR14a dilutions and vortex thoroughly before use.
Initial agonist response followed by loss of signal (antagonist-like effect)	Receptor desensitization and internalization.	This may be an inherent property of JR14a. To investigate, pre-treat cells with JR14a for varying times before adding C3a to see if the C3a response is blunted.

Mast Cell Degranulation (β -Hexosaminidase Release) Assay

This assay quantifies the release of the granular enzyme β -hexosaminidase from mast cells as a measure of degranulation.

Detailed Protocol:

- Cell Preparation:

- Culture LAD2 mast cells according to established protocols.
- Sensitize cells with IgE overnight if studying IgE-mediated degranulation.
- Wash the cells and resuspend them in a suitable buffer (e.g., HEPES buffer with BSA).
- Assay Procedure:
 - Aliquot cells into a 96-well plate.
 - To measure antagonism, pre-incubate the cells with various concentrations of **JR14a** for 30 minutes at 37°C.
 - Induce degranulation by adding a C3aR agonist (e.g., C3a).
 - Incubate for 30 minutes at 37°C.
 - Centrifuge the plate to pellet the cells.
- Enzyme Activity Measurement:
 - Transfer the supernatant to a new plate.
 - Lyse the remaining cells with Triton X-100 to determine the total β -hexosaminidase content.
 - Add the substrate p-nitrophenyl-N-acetyl- β -D-glucosaminide (PNAG) to both the supernatant and lysate samples.
 - Incubate for 60-90 minutes at 37°C.
 - Stop the reaction with a stop solution (e.g., glycine buffer).
 - Read the absorbance at 405 nm.
- Data Analysis:
 - Calculate the percentage of β -hexosaminidase release for each condition.

- Plot the percentage of inhibition against the **JR14a** concentration to determine the IC50 value.

Troubleshooting Guide: β -Hexosaminidase Release Assay

Issue	Possible Cause(s)	Suggested Solution(s)
High spontaneous release	Poor cell health; rough handling of cells.	Ensure cells are healthy and not over-confluent. Handle cells gently during washing and plating.
Low signal window (low release with agonist)	Insufficient agonist concentration; low C3aR expression.	Optimize the concentration of the C3aR agonist. Confirm C3aR expression on the mast cells.
JR14a shows agonist activity (induces degranulation)	This may occur at high concentrations of JR14a.	Test a wider range of JR14a concentrations to identify a window where it acts as an antagonist without causing degranulation itself.
Inconsistent results	Variation in cell number; temperature fluctuations.	Use a cell counter for accurate plating. Ensure all incubations are performed at a stable 37°C.

cAMP Accumulation Assay

This assay measures the inhibition of adenylyl cyclase activity (and thus cAMP production) following the activation of the G α i-coupled C3aR.

Detailed Protocol:

- Cell Preparation:
 - Culture cells (e.g., HEK293-C3aR, THP-1) in 96-well plates.

- On the day of the assay, replace the culture medium with stimulation buffer containing a phosphodiesterase (PDE) inhibitor like IBMX to prevent cAMP degradation.
- Assay Procedure:
 - Pre-incubate the cells with the PDE inhibitor for 15-30 minutes.
 - Add various concentrations of **JR14a** to the cells.
 - Stimulate the cells with forskolin (an adenylyl cyclase activator) to induce cAMP production.
 - Incubate for 15-30 minutes at 37°C.
- cAMP Measurement:
 - Lyse the cells.
 - Measure cAMP levels using a commercially available kit (e.g., HTRF, ELISA, or luminescence-based assays) following the manufacturer's instructions.
- Data Analysis:
 - Generate a standard curve using known cAMP concentrations.
 - Calculate the amount of cAMP produced in each sample.
 - Plot the inhibition of forskolin-induced cAMP production against the **JR14a** concentration to determine the IC50 value.

Troubleshooting Guide: cAMP Assay

Issue	Possible Cause(s)	Suggested Solution(s)
High basal cAMP levels	Constitutive C3aR activity; issues with the cell line.	Ensure the use of low-passage cells. If constitutive activity is high, it may be a characteristic of the receptor expression level.
Poor forskolin stimulation	Inactive forskolin; insufficient incubation time.	Use a fresh preparation of forskolin. Optimize the forskolin concentration and stimulation time.
No inhibition by JR14a	Low C3aR coupling to G α i; inactive JR14a.	Confirm that C3aR is functionally coupled to the G α i pathway in your cell line. Use a fresh aliquot of JR14a.
High variability	Cell plating inconsistency; assay edge effects.	Ensure uniform cell seeding. Avoid using the outer wells of the plate or fill them with buffer to minimize edge effects.

Quantitative Data Summary

The following tables summarize key quantitative data reported for **JR14a** in various in vitro and in vivo models.

Table 1: In Vitro Activity of **JR14a**

Assay	Cell Line	Parameter	Value	Reference
β -Hexosaminidase Release Inhibition	Human LAD2 Mast Cells	IC50	8 nM	[1][2]
Intracellular Ca^{2+} Release Inhibition	Human Monocyte-Derived Macrophages	IC50	10 nM	[1][2]
cAMP Inhibition (Gi activation)	HEK293-C3aR	EC50	~1 nM	[3]
β -Arrestin Recruitment	HEK293-C3aR	EC50	~5 nM	[3]

Table 2: In Vivo Pharmacokinetics of **JR14a** in Rats

Route of Administration	Dose	Cmax	Tmax	t1/2	AUC	Reference
Intravenous (i.v.)	1 mg/kg	-	-	191 min	3795 ng·h/mL	[1]
Oral (p.o.)	10 mg/kg	88 ng/mL	300 min	-	478 ng·h/mL	[1]

Table 3: Troubleshooting Logic for **JR14a** Variability

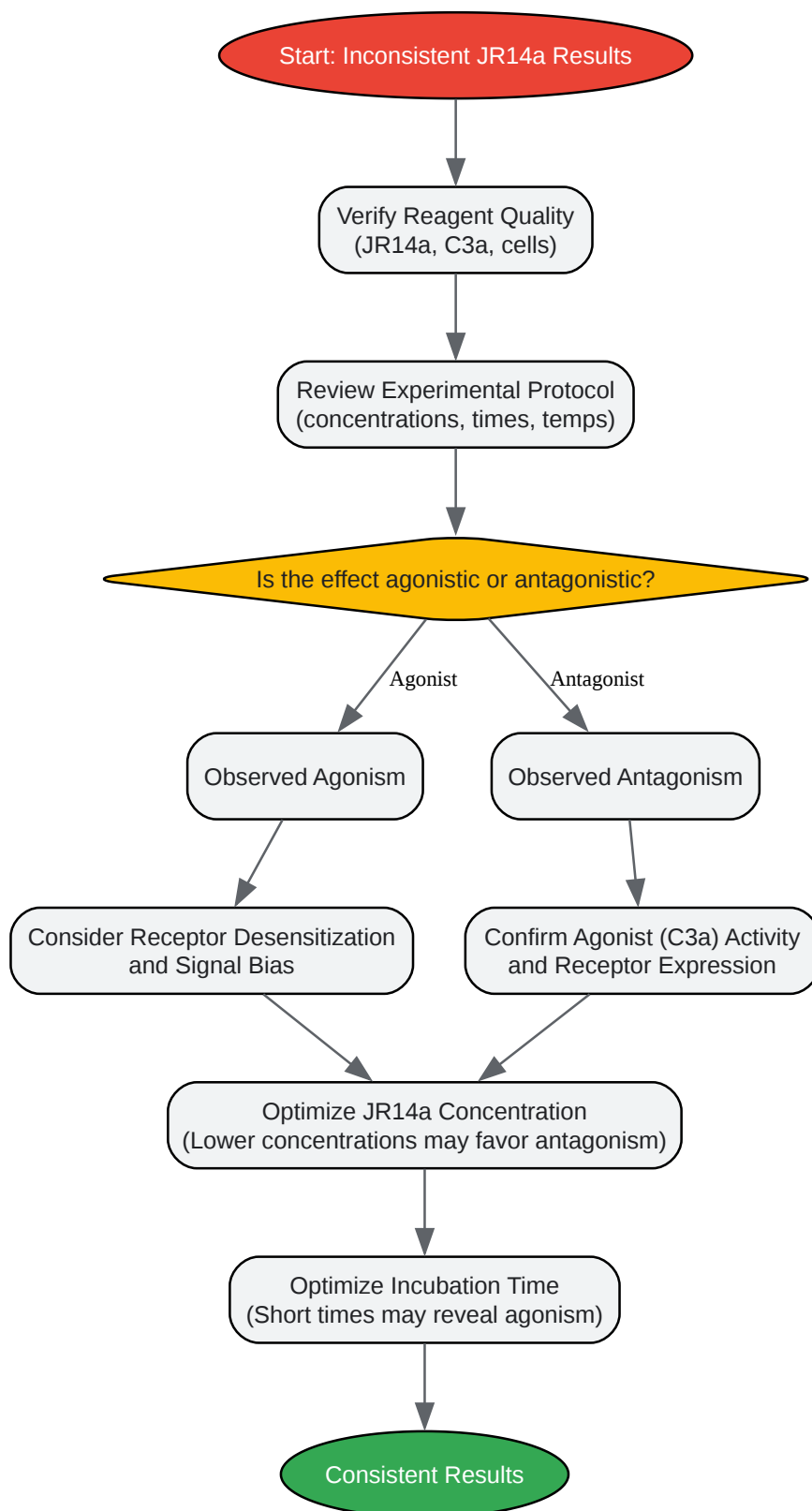

[Click to download full resolution via product page](#)

Caption: A logical approach to troubleshooting **JR14a** variability.

Need Custom Synthesis?

BenchChem offers custom synthesis for rare earth carbides and specific isotopic labeling.

Email: info@benchchem.com or [Request Quote Online](#).

References

- [1. researchgate.net \[researchgate.net\]](#)
- [2. benchchem.com \[benchchem.com\]](#)
- [3. Measuring Mast Cell Mediator Release - PMC \[pmc.ncbi.nlm.nih.gov\]](#)
- [4. abmgood.com \[abmgood.com\]](#)
- [5. researchgate.net \[researchgate.net\]](#)
- [6. Structural insights into the agonist activity of the nonpeptide modulator JR14a on C3aR - PMC \[pmc.ncbi.nlm.nih.gov\]](#)
- [7. Structural insights into small-molecule agonist recognition and activation of complement receptor C3aR - PMC \[pmc.ncbi.nlm.nih.gov\]](#)
- [8. A Novel Class of Complement 3a Receptor Agonists and Antagonists Derived from the TLQP-21 Peptide - PMC \[pmc.ncbi.nlm.nih.gov\]](#)
- [9. Detecting degranulation via hexosaminidase assay \[protocols.io\]](#)
- [10. benchchem.com \[benchchem.com\]](#)
- To cite this document: BenchChem. [Technical Support Center: Overcoming JR14a Variability in Experimental Results]. BenchChem, [2026]. [Online PDF]. Available at: [<https://www.benchchem.com/product/b10819433/docs#technical-support-center-overcoming-jr14a-variability-in-experimental-results>]

Disclaimer & Data Validity:

The information provided in this document is for Research Use Only (RUO) and is strictly not intended for diagnostic or therapeutic procedures. While BenchChem strives to provide accurate protocols, we make no warranties, express or implied, regarding the fitness of this product for every specific experimental setup.

Technical Support: The protocols provided are for reference purposes. Unsure if this reagent suits your experiment?

Need Industrial/Bulk Grade? [Request Custom Synthesis Quote](#)

BenchChem

Our mission is to be the trusted global source of essential and advanced chemicals, empowering scientists and researchers to drive progress in science and industry.

Contact

Address: 3281 E Guasti Rd
Ontario, CA 91761, United States
Phone: (601) 213-4426
Email: info@benchchem.com

[Contact our Ph.D. Support Team for a compatibility check](#)