

# Technical Support Center: Optimizing BAY-179 Permeability in Caco-2 Assays

**Author:** BenchChem Technical Support Team. **Date:** April 2026

## Compound of Interest

Compound Name: BAY-179  
Cat. No.: B10819848

[Get Quote](#)

Welcome to the technical support center for researchers utilizing Caco-2 assays to evaluate the permeability of **BAY-179**. This resource provides troubleshooting guidance and frequently asked questions (FAQs) to address common challenges encountered during these experiments.

## Troubleshooting Guides

This section provides solutions to specific problems you may encounter when assessing the permeability of **BAY-179**.

### Issue 1: Low Apparent Permeability ( $P_{app}$ ) of **BAY-179**

If you are observing a lower than expected apparent permeability ( $P_{app}$ ) for **BAY-179** in the apical to basolateral (A  $\rightarrow$  B) direction, consider the following troubleshooting steps.

Potential Cause	Recommended Action	Rationale
Poor Aqueous Solubility	Increase the concentration of a co-solvent like DMSO (up to 1%) in the transport buffer. Ensure the final concentration does not compromise monolayer integrity.	Many drug candidates exhibit low aqueous solubility, which can limit the concentration of the compound available for transport across the Caco-2 monolayer.[1][2][3]
Active Efflux	Perform a bi-directional transport assay (A → B and B → A) to determine the efflux ratio. If the efflux ratio is >2, consider co-incubating with a general P-gp inhibitor (e.g., verapamil) or a BCRP inhibitor (e.g., fumitremorgin C).[4][5]	Caco-2 cells express various efflux transporters, such as P-glycoprotein (P-gp) and Breast Cancer Resistance Protein (BCRP), which can actively pump the compound back into the apical chamber, reducing the net A → B transport.[4][6]
Low Compound Recovery	See "Issue 2: Poor Compound Recovery" for detailed steps.	If the total amount of BAY-179 recovered from both apical and basolateral chambers is low, it can lead to an underestimation of the Papp value.[7]
Monolayer Integrity Issues	Verify the transepithelial electrical resistance (TEER) values are within the acceptable range for your laboratory (typically >200 Ω·cm <sup>2</sup> ). Perform a Lucifer Yellow rejection assay to confirm low paracellular leakage.[4][8]	A compromised Caco-2 monolayer with leaky tight junctions will not accurately model intestinal permeability.

## Issue 2: Poor Compound Recovery of **BAY-179**

Low recovery of **BAY-179** at the end of the assay can lead to inaccurate permeability assessment.

Potential Cause	Recommended Action	Rationale
Nonspecific Binding	Pre-treat collection plates with an organic solvent. Use low-binding plates and pipette tips. Include a protein like Bovine Serum Albumin (BSA) in the basolateral receiver buffer.[7] [9]	Hydrophobic compounds can bind to plastic surfaces of the assay plates and labware, reducing the concentration available for analysis.[7]
Compound Instability	Assess the stability of BAY-179 in the assay buffer over the incubation period. If instability is observed, consider shortening the incubation time.	The compound may degrade in the aqueous buffer at 37°C over the course of the experiment.
Cellular Metabolism	Analyze cell lysates to determine if BAY-179 is being metabolized by the Caco-2 cells.	Caco-2 cells can express some metabolic enzymes that may alter the structure of the test compound.[10]

## Frequently Asked Questions (FAQs)

Q1: What is a typical Caco-2 cell culture and differentiation period?

A1: Caco-2 cells are typically cultured for 21 days post-seeding on semi-permeable inserts to allow for spontaneous differentiation into a polarized monolayer with well-defined tight junctions, mimicking the intestinal epithelium.[4][5]

Q2: How do I determine if **BAY-179** is a substrate for active efflux transporters?

A2: To assess active efflux, a bi-directional permeability assay is necessary. You will measure the transport of **BAY-179** from the apical to the basolateral side (A → B) and from the basolateral to the apical side (B → A). An efflux ratio, calculated as  $P_{app}(B \rightarrow A) / P_{app}(A \rightarrow B)$ , greater than 2 suggests that the compound is subject to active efflux.[4][5]

Q3: What are the recommended control compounds for a Caco-2 permeability assay?

A3: It is recommended to include high and low permeability control compounds in each assay. Commonly used controls include:

- Atenolol: A low permeability, paracellularly transported compound.[5]
- Propranolol or Antipyrine: High permeability, transcellularly transported compounds.[4][5]
- Digoxin or Talinolol: Known P-gp substrates to verify the activity of efflux transporters.[4][5]

Q4: How can I improve the permeability of a highly lipophilic compound like **BAY-179**?

A4: For highly lipophilic compounds, you can try optimizing the assay conditions. This may include adding Bovine Serum Albumin (BSA) to the receiver medium to mimic physiological conditions and improve the solubility of the compound once it crosses the monolayer. Increasing the stirring rate during the assay can also reduce the impact of the unstirred water layer.[9]

## Experimental Protocols

### Standard Caco-2 Permeability Assay Protocol

This protocol outlines the key steps for performing a uni-directional (A → B) permeability assay.

- Cell Culture:
  - Culture Caco-2 cells on semi-permeable Transwell™ inserts for 21 days.
  - Replace the culture medium every 2-3 days.
- Monolayer Integrity Check:
  - Before the experiment, measure the Transepithelial Electrical Resistance (TEER) of each monolayer. Ensure values are above the established threshold for your lab (e.g., >200  $\Omega \cdot \text{cm}^2$ ).[8]
- Assay Preparation:

- Wash the Caco-2 monolayers with pre-warmed (37°C) transport buffer (e.g., Hanks' Balanced Salt Solution with HEPES).
- Equilibrate the monolayers with transport buffer for 30 minutes at 37°C.
- Dosing and Incubation:
  - Prepare the dosing solution of **BAY-179** in transport buffer. The final concentration of any co-solvent (like DMSO) should be low (e.g., <1%).
  - Remove the equilibration buffer from the apical (donor) chamber and replace it with the **BAY-179** dosing solution.
  - Add fresh transport buffer to the basolateral (receiver) chamber.
  - Incubate the plate at 37°C with gentle shaking for a defined period (e.g., 2 hours).
- Sampling and Analysis:
  - At the end of the incubation, take samples from both the apical and basolateral chambers.
  - Analyze the concentration of **BAY-179** in the samples using a suitable analytical method, such as LC-MS/MS.[6]
- Data Analysis:
  - Calculate the apparent permeability coefficient (P<sub>app</sub>) using the following formula:
    - $P_{app} \text{ (cm/s)} = (dQ/dt) / (A * C_0)$
    - Where dQ/dt is the rate of compound appearance in the receiver chamber, A is the surface area of the insert, and C<sub>0</sub> is the initial concentration in the donor chamber.[4]

## Visualizations

Below are diagrams illustrating key workflows and concepts relevant to Caco-2 permeability assays.

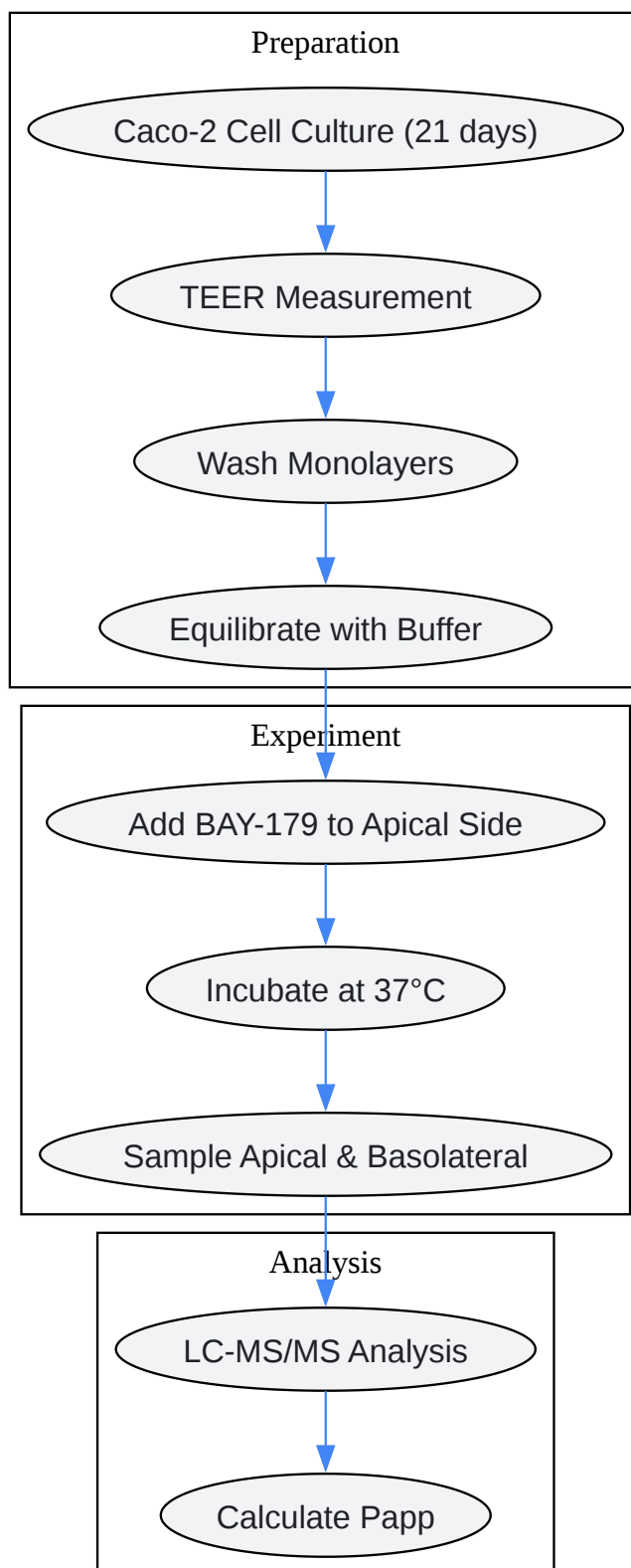

[Click to download full resolution via product page](#)

Caption: Workflow for a standard Caco-2 permeability assay.

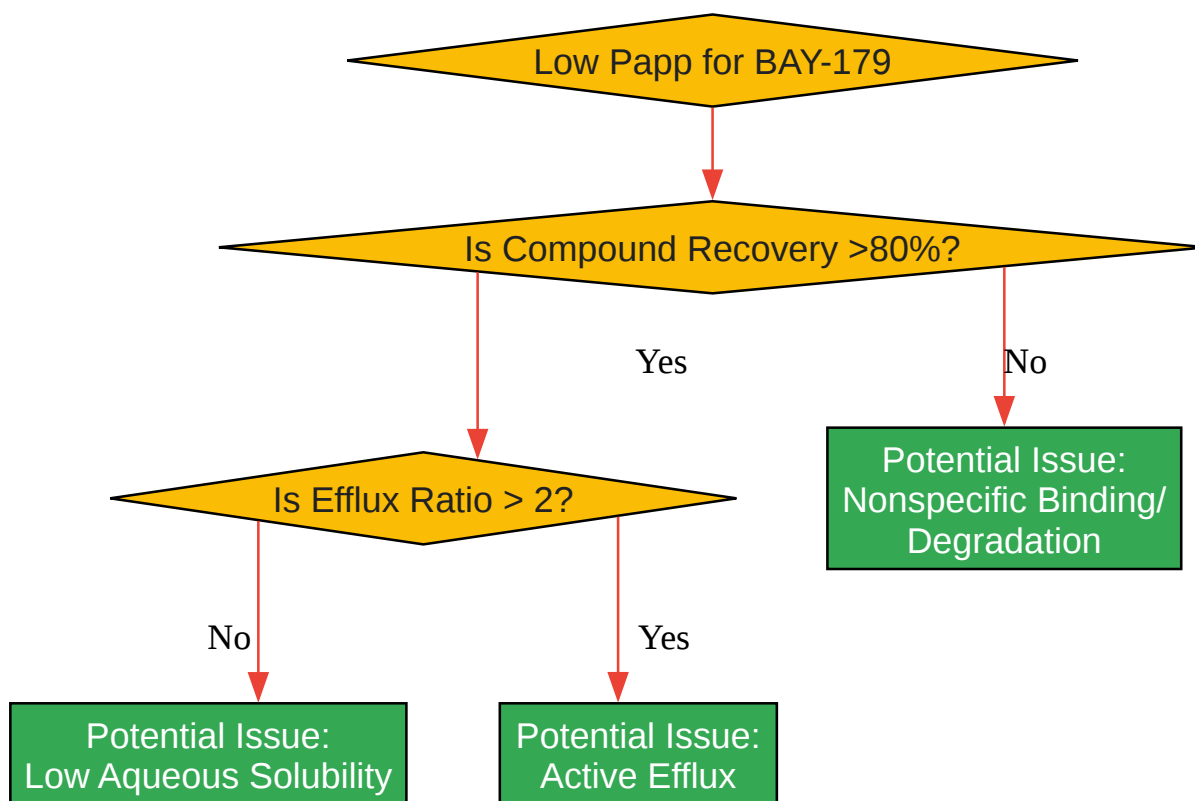

[Click to download full resolution via product page](#)

Caption: Troubleshooting logic for low apparent permeability.

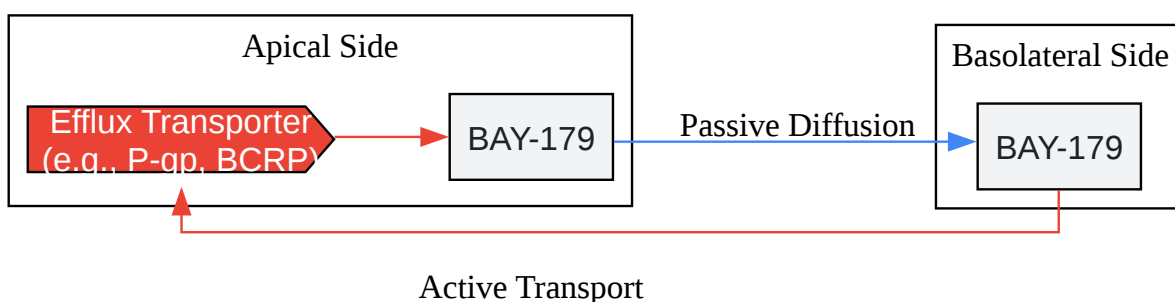

[Click to download full resolution via product page](#)

Caption: Transcellular transport pathways in Caco-2 cells.

### Need Custom Synthesis?

BenchChem offers custom synthesis for rare earth carbides and specific isotopic labeling.

Email: [info@benchchem.com](mailto:info@benchchem.com) or [Request Quote Online](#).

## References

- 1. Optimization of the Caco-2 Permeability Assay to Screen Drug Compounds for Intestinal Absorption and Efflux | Springer Nature Experiments [[experiments.springernature.com](https://experiments.springernature.com)]
- 2. Optimization of the Caco-2 permeability assay to screen drug compounds for intestinal absorption and efflux - PubMed [[pubmed.ncbi.nlm.nih.gov](https://pubmed.ncbi.nlm.nih.gov)]
- 3. [researchgate.net](https://researchgate.net) [[researchgate.net](https://researchgate.net)]
- 4. Caco-2 permeability assay - Creative Bioarray | Creative Bioarray [[creative-bioarray.com](https://creative-bioarray.com)]
- 5. Caco-2 Permeability | Evotec [[evotec.com](https://evotec.com)]
- 6. [enamine.net](https://enamine.net) [[enamine.net](https://enamine.net)]
- 7. Approach to improve compound recovery in a high-throughput Caco-2 permeability assay supported by liquid chromatography-tandem mass spectrometry - PubMed [[pubmed.ncbi.nlm.nih.gov](https://pubmed.ncbi.nlm.nih.gov)]
- 8. [static1.1.sqspcdn.com](https://static1.1.sqspcdn.com) [[static1.1.sqspcdn.com](https://static1.1.sqspcdn.com)]
- 9. Optimisation of the caco-2 permeability assay using experimental design methodology - PubMed [[pubmed.ncbi.nlm.nih.gov](https://pubmed.ncbi.nlm.nih.gov)]
- 10. Caco-2 cell permeability assays to measure drug absorption - PubMed [[pubmed.ncbi.nlm.nih.gov](https://pubmed.ncbi.nlm.nih.gov)]
- To cite this document: BenchChem. [Technical Support Center: Optimizing BAY-179 Permeability in Caco-2 Assays]. BenchChem, [2026]. [Online PDF]. Available at: [<https://www.benchchem.com/product/b10819848/docs#technical-support-center-optimizing-bay-179-permeability-in-caco-2-assays>]

---

### Disclaimer & Data Validity:

The information provided in this document is for Research Use Only (RUO) and is strictly not intended for diagnostic or therapeutic procedures. While BenchChem strives to provide

accurate protocols, we make no warranties, express or implied, regarding the fitness of this product for every specific experimental setup.

**Technical Support:** The protocols provided are for reference purposes. Unsure if this reagent suits your experiment?

**Need Industrial/Bulk Grade?** [Request Custom Synthesis Quote](#)

## BenchChem

Our mission is to be the trusted global source of essential and advanced chemicals, empowering scientists and researchers to drive progress in science and industry.

### Contact

Address: 3281 E Guasti Rd  
Ontario, CA 91761, United States  
Phone: (601) 213-4426  
Email: [info@benchchem.com](mailto:info@benchchem.com)

[Contact our Ph.D. Support Team for a compatibility check](#)