

Technical Support Center: Optimizing BAY-179 Concentration for Cell Viability Assays

Author: BenchChem Technical Support Team. **Date:** April 2026

Compound of Interest

Compound Name: BAY-179
Cat. No.: B10819848

[Get Quote](#)

This technical support center provides researchers, scientists, and drug development professionals with troubleshooting guides and frequently asked questions (FAQs) for optimizing the use of **BAY-179** in cell viability assays.

Frequently Asked Questions (FAQs)

Q1: What is **BAY-179** and what is its primary mechanism of action?

A1: **BAY-179** is a potent and selective chemical probe that acts as a mitochondrial complex I inhibitor.^{[1][2]} Its primary mechanism is the inhibition of the electron transport chain at complex I, leading to decreased ATP production and inducing cellular stress.^{[1][3]} It is a valuable tool for investigating the biological significance of complex I inhibition in various contexts, particularly in cancer research.^{[1][3]}

Q2: What is a good starting concentration range for **BAY-179** in a cell viability assay?

A2: A good starting point for a dose-response experiment with **BAY-179** would be a wide concentration range spanning from low nanomolar to low micromolar (e.g., 1 nM to 10 μM). The IC₅₀ values for complex I inhibition are in the nanomolar range for human, mouse, rat, and dog cells, suggesting that effects on cell viability will likely be observed in a similar range.^[2]

However, the optimal concentration is highly dependent on the cell line and the duration of the assay.

Q3: How long should I incubate cells with **BAY-179**?

A3: The incubation time for **BAY-179** can significantly impact the observed effect on cell viability.^{[4][5]} A common starting point is 24 to 72 hours. Shorter incubation times may not be sufficient to observe significant effects on cell proliferation, while longer incubation times can lead to secondary effects not directly related to the initial inhibition of complex I.^[6] It is recommended to perform a time-course experiment (e.g., 24, 48, and 72 hours) to determine the optimal endpoint for your specific cell line and experimental question.

Q4: Can **BAY-179** have off-target effects?

A4: While **BAY-179** is described as a selective complex I inhibitor, it is crucial to consider the possibility of off-target effects, especially at higher concentrations.^[1] An analog of **BAY-179** has shown selectivity against other complexes of the respiratory chain. However, comprehensive kinome-wide selectivity profiling data for **BAY-179** is not readily available in the provided search results. As with any small molecule inhibitor, it is good practice to use the lowest effective concentration to minimize the risk of off-target activities.

Q5: How does **BAY-179**-induced cell death typically occur?

A5: Inhibition of mitochondrial complex I can lead to both apoptosis (programmed cell death) and necrosis (uncontrolled cell death).^{[7][8]} The dominant mode of cell death can be concentration- and cell-type-dependent.^[9] At lower concentrations, apoptosis is often the primary mechanism, while higher concentrations may lead to necrosis due to severe energy depletion.^[9] It is advisable to perform assays that can distinguish between these two cell death mechanisms, such as Annexin V/PI staining.

Troubleshooting Guides

Issue 1: No significant decrease in cell viability is observed.

Possible Cause	Troubleshooting Step
Insufficient Concentration	The concentration of BAY-179 may be too low for your specific cell line. Perform a dose-response experiment with a wider and higher concentration range (e.g., up to 50 μ M).
Short Incubation Time	The cytotoxic effects of BAY-179 may be time-dependent.[4][5][10] Increase the incubation time (e.g., up to 72 hours or longer) and perform a time-course experiment.
Cell Line Resistance	Some cell lines may be inherently resistant to complex I inhibition due to metabolic plasticity, such as an increased reliance on glycolysis.[11] Consider using a cell line known to be sensitive to mitochondrial inhibitors or measure lactate production to assess glycolytic activity.
Compound Instability	BAY-179 may be unstable in your cell culture medium over long incubation periods. Prepare fresh dilutions of the compound for each experiment and minimize exposure to light.
Assay Interference	The chosen viability assay may not be suitable. For example, assays relying on metabolic activity (e.g., MTT, XTT) can be confounded by the metabolic effects of BAY-179.[12] Use an orthogonal assay that measures a different parameter, such as cell number (e.g., crystal violet staining) or membrane integrity (e.g., LDH release).

Issue 2: High variability between replicate wells.

Possible Cause	Troubleshooting Step
Uneven Cell Seeding	Ensure a homogenous single-cell suspension before seeding. After seeding, allow plates to sit at room temperature for a short period to allow for even cell distribution before transferring to the incubator.
Edge Effects	Evaporation from the outer wells of a microplate can concentrate the compound and affect cell growth. To mitigate this, fill the outer wells with sterile PBS or medium without cells and do not use them for experimental data.
Compound Precipitation	At higher concentrations, BAY-179 may precipitate out of the medium. Visually inspect the wells under a microscope for any signs of precipitation. If observed, consider using a lower top concentration or a different solvent.
Pipetting Errors	Ensure accurate and consistent pipetting, especially when performing serial dilutions. Use calibrated pipettes and fresh tips for each dilution.

Issue 3: Unexpected dose-response curve (e.g., U-shaped curve).

Possible Cause	Troubleshooting Step
Compound Precipitation at High Concentrations	<p>As mentioned above, compound precipitation can scatter light and interfere with absorbance or fluorescence readings, leading to an apparent increase in viability at high concentrations.[13]</p> <p>Visually inspect the wells and consider a solubility assay for BAY-179 in your specific medium.</p>
Off-Target Effects at High Concentrations	<p>At high concentrations, BAY-179 might engage off-target molecules that could promote survival or interfere with the assay chemistry.[14] Try to stay within a concentration range that is relevant to its known IC50 for complex I inhibition.</p>
Assay Artifact	<p>Some assay reagents can be directly affected by the chemical properties of the test compound.[13] Run a cell-free control where you add BAY-179 to the medium and the assay reagent to check for any direct chemical interaction.</p>
Cellular Stress Response	<p>At certain concentrations, cells might activate pro-survival signaling pathways in response to mitochondrial stress, leading to a temporary increase in viability markers.[15] Analyze markers of cellular stress and specific signaling pathways to investigate this possibility.</p>

Experimental Protocols

Protocol 1: ATP-Based Cell Viability Assay

This protocol is recommended for assessing the direct impact of **BAY-179** on cellular energy levels.

Materials:

- Target cell line
- Complete cell culture medium
- **BAY-179** stock solution (e.g., 10 mM in DMSO)
- Opaque-walled 96-well plates
- Luminescent ATP detection reagent (e.g., CellTiter-Glo®)
- Plate reader with luminescence detection capabilities

Methodology:

- Cell Seeding: Seed cells into an opaque-walled 96-well plate at a predetermined optimal density and allow them to adhere overnight.
- Compound Preparation: Prepare serial dilutions of **BAY-179** in complete cell culture medium to achieve the desired final concentrations. Include a vehicle control (DMSO) at the same final concentration as the highest **BAY-179** treatment.
- Cell Treatment: Remove the seeding medium and add 100 µL of the prepared **BAY-179** dilutions or vehicle control to the respective wells.
- Incubation: Incubate the plate for the desired duration (e.g., 24, 48, or 72 hours) at 37°C in a humidified incubator with 5% CO₂.
- ATP Measurement:
 - Equilibrate the plate and the ATP detection reagent to room temperature.
 - Add the ATP detection reagent to each well according to the manufacturer's instructions (typically a 1:1 ratio with the culture medium).
 - Mix the contents on an orbital shaker for 2 minutes to induce cell lysis.
 - Incubate at room temperature for 10 minutes to stabilize the luminescent signal.[\[16\]](#)

- Data Acquisition: Measure the luminescence using a plate reader.
- Data Analysis: Normalize the data to the vehicle control (set as 100% viability) and plot the results as a dose-response curve to determine the IC50 value.

Protocol 2: Annexin V/Propidium Iodide (PI) Apoptosis Assay

This flow cytometry-based assay distinguishes between viable, early apoptotic, late apoptotic, and necrotic cells.

Materials:

- Target cell line
- Complete cell culture medium
- **BAY-179** stock solution (e.g., 10 mM in DMSO)
- 6-well plates
- Annexin V-FITC and Propidium Iodide (PI) staining kit
- Flow cytometer

Methodology:

- Cell Seeding and Treatment: Seed cells in 6-well plates and treat with desired concentrations of **BAY-179** or vehicle control for the chosen duration.
- Cell Harvesting: Collect both adherent and floating cells. For adherent cells, use a gentle dissociation reagent.
- Staining:
 - Wash the cells with cold PBS.
 - Resuspend the cell pellet in 1X Annexin V binding buffer.

- Add Annexin V-FITC and PI according to the manufacturer's protocol.
- Incubate in the dark at room temperature for 15 minutes.[13]
- Flow Cytometry Analysis: Analyze the stained cells on a flow cytometer within one hour of staining.
- Data Interpretation:
 - Viable cells: Annexin V-negative and PI-negative
 - Early apoptotic cells: Annexin V-positive and PI-negative
 - Late apoptotic/necrotic cells: Annexin V-positive and PI-positive

Data Presentation

Table 1: Representative IC50 Values for Complex I Inhibition by **BAY-179**

Species	IC50 (nM)
Human	79
Mouse	38
Rat	27
Dog	47

Data sourced from MedChemExpress and indicates the concentration required to inhibit 50% of complex I activity, not necessarily cell viability.[2]

Table 2: Troubleshooting Summary for Cell Viability Assays with **BAY-179**

Issue	Potential Cause	Recommended Action
No Effect	Insufficient concentration/time, cell resistance	Increase dose/duration, use sensitive cell line, check glycolysis
High Variability	Uneven seeding, edge effects, precipitation	Optimize seeding, use perimeter wells for blanks, check solubility
U-shaped Curve	Precipitation, off-target effects, assay artifact	Visual inspection, use lower concentrations, run cell-free controls

Visualizations

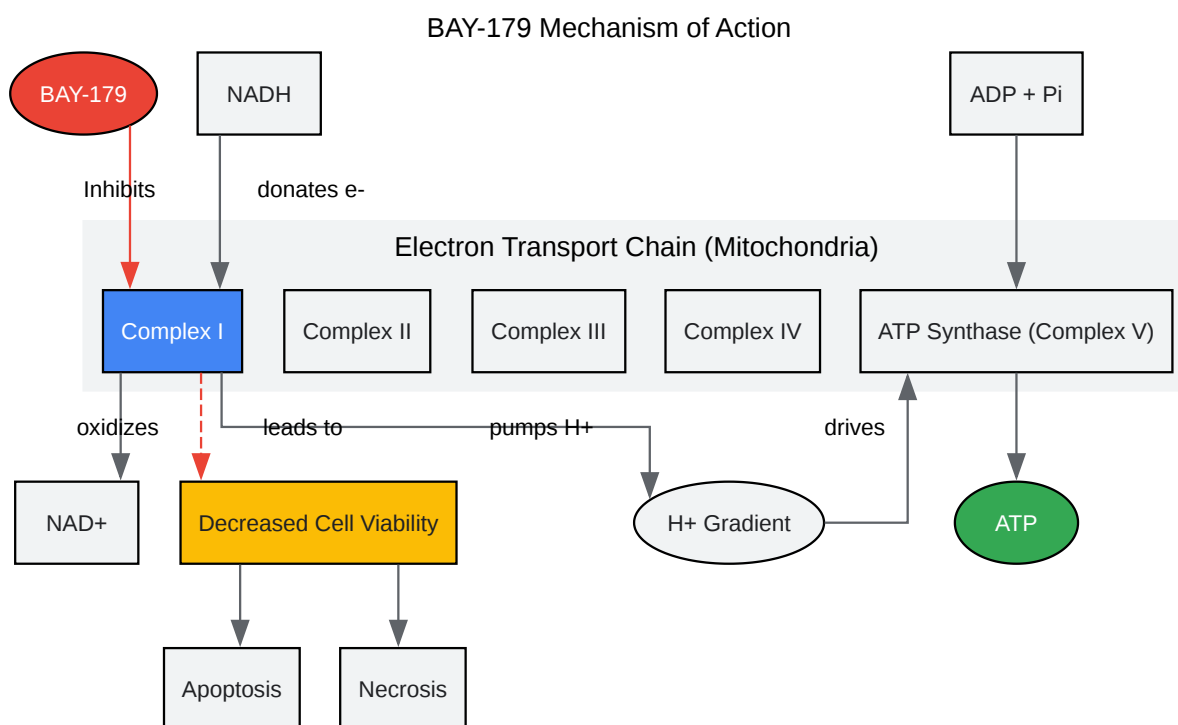

[Click to download full resolution via product page](#)

Caption: Signaling pathway of **BAY-179** leading to decreased cell viability.

Troubleshooting Workflow for BAY-179 Viability Assays

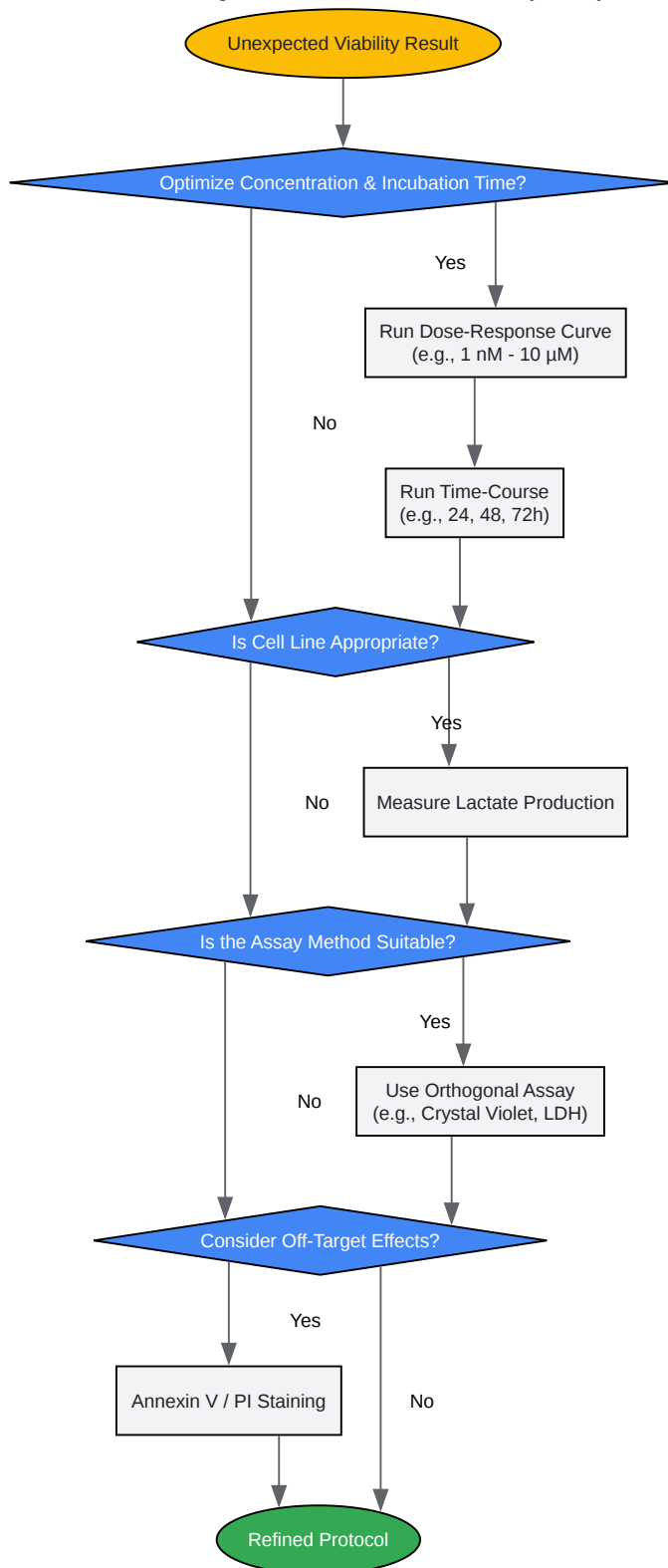

[Click to download full resolution via product page](#)

Caption: A logical workflow for troubleshooting **BAY-179** cell viability assays.

Need Custom Synthesis?

BenchChem offers custom synthesis for rare earth carbides and specific isotopic labeling.

Email: info@benchchem.com or [Request Quote Online](#).

References

- 1. Identification of the Highly Active, Species Cross-Reactive Complex I Inhibitor BAY-179 - PMC [[pmc.ncbi.nlm.nih.gov](https://pubmed.ncbi.nlm.nih.gov)]
- 2. medchemexpress.com [medchemexpress.com]
- 3. Identification of the Highly Active, Species Cross-Reactive Complex I Inhibitor BAY-179 - PubMed [pubmed.ncbi.nlm.nih.gov]
- 4. Time-dependent cytotoxic drugs selectively cooperate with IL-18 for cancer chemo-immunotherapy - PMC [[pmc.ncbi.nlm.nih.gov](https://pubmed.ncbi.nlm.nih.gov)]
- 5. Can Cytotoxic Effects Induced by Industrial Chemicals be Time-dependent? - PubMed [pubmed.ncbi.nlm.nih.gov]
- 6. In Vitro Long-Term Proliferation Assays to Study Antiproliferative Effects of PARP Inhibitors on Cancer Cells - PubMed [pubmed.ncbi.nlm.nih.gov]
- 7. What is the difference between necrosis and apoptosis? | Proteintech Group [ptglab.com]
- 8. Induction of apoptosis as well as necrosis by hypoxia and predominant prevention of apoptosis by Bcl-2 and Bcl-XL - PubMed [pubmed.ncbi.nlm.nih.gov]
- 9. In vitro induction of apoptosis vs. necrosis by widely used preservatives: 2-phenoxyethanol, a mixture of isothiazolinones, imidazolidinyl urea and 1,2-pentanediol - PubMed [pubmed.ncbi.nlm.nih.gov]
- 10. Time-dependent cytotoxic drugs selectively cooperate with IL-18 for cancer chemo-immunotherapy - PubMed [pubmed.ncbi.nlm.nih.gov]
- 11. Synergistic Anticancer Effect of Glycolysis and Histone Deacetylases Inhibitors in a Glioblastoma Model - PMC [[pmc.ncbi.nlm.nih.gov](https://pubmed.ncbi.nlm.nih.gov)]
- 12. pitfalls-of-the-mtt-assay-direct-and-off-target-effects-of-inhibitors-can-result-in-over-underevaluation-of-cell-viability - Ask this paper | Bohrium [bohrium.com]
- 13. benchchem.com [benchchem.com]
- 14. A Potential Off-Target Effect of the Wnt/ β -Catenin Inhibitor KYA1797K: PD-L1 Binding and Checkpoint Inhibition - PMC [[pmc.ncbi.nlm.nih.gov](https://pubmed.ncbi.nlm.nih.gov)]

- [15. Advances in Targeting Signal Transduction Pathways - PMC \[pmc.ncbi.nlm.nih.gov\]](#)
- [16. Medicinal plants that can help with diabetes - Diabetes Action Research and Education Foundation \[diabetesaction.org\]](#)
- To cite this document: BenchChem. [Technical Support Center: Optimizing BAY-179 Concentration for Cell Viability Assays]. BenchChem, [2026]. [Online PDF]. Available at: [<https://www.benchchem.com/product/b10819848/docs#technical-support-center-optimizing-bay-179-concentration-for-cell-viability-assays>]

Disclaimer & Data Validity:

The information provided in this document is for Research Use Only (RUO) and is strictly not intended for diagnostic or therapeutic procedures. While BenchChem strives to provide accurate protocols, we make no warranties, express or implied, regarding the fitness of this product for every specific experimental setup.

Technical Support: The protocols provided are for reference purposes. Unsure if this reagent suits your experiment?

Need Industrial/Bulk Grade? [Request Custom Synthesis Quote](#)

BenchChem

Our mission is to be the trusted global source of essential and advanced chemicals, empowering scientists and researchers to drive progress in science and industry.

Contact

Address: 3281 E Guasti Rd
Ontario, CA 91761, United States
Phone: (601) 213-4426
Email: info@benchchem.com

[Contact our Ph.D. Support Team for a compatibility check](#)

