

Investigating Isodeoxyelephantopin: A Technical Support Center for Researchers

Author: BenchChem Technical Support Team. **Date:** April 2026

Compound of Interest

Compound Name: *Isodeoxyelephantopin*

Cat. No.: *B10819811*

[Get Quote](#)

For researchers, scientists, and drug development professionals utilizing **Isodeoxyelephantopin** (IDET), this technical support center provides essential information, troubleshooting guides, and frequently asked questions to facilitate smooth and effective experimentation. This resource addresses potential off-target effects and provides clarity on the compound's mechanism of action.

Isodeoxyelephantopin, a sesquiterpene lactone, and its isomer Deoxyelephantopin (DET), have garnered significant interest for their anti-cancer properties. These compounds exhibit a multi-targeted approach, influencing several signaling pathways crucial for cancer cell proliferation, survival, and metastasis. While this polypharmacology is beneficial for therapeutic efficacy, it also raises questions about potential off-target effects. This guide aims to provide researchers with the necessary information to design experiments, interpret results, and troubleshoot potential issues related to the use of **Isodeoxyelephantopin**.

Frequently Asked Questions (FAQs)

Q1: What are the known primary targets and mechanisms of action of **Isodeoxyelephantopin**?

A1: **Isodeoxyelephantopin** and its isomer, Deoxyelephantopin, exert their anti-cancer effects through the modulation of multiple signaling pathways.^{[1][2][3][4]} Key mechanisms include:

- **Inhibition of NF- κ B Signaling:** IDET suppresses the activation of NF- κ B, a key transcription factor involved in inflammation, cell survival, and proliferation.[5] This is achieved by inhibiting I κ B α kinase, which prevents the degradation of I κ B α and the subsequent nuclear translocation of p65.
- **Modulation of STAT3 Signaling:** These compounds have been shown to inhibit the activation of STAT3, another critical transcription factor for tumor progression.
- **Induction of Reactive Oxygen Species (ROS):** IDET can induce the generation of ROS within cancer cells, leading to oxidative stress and subsequent apoptosis.[5]
- **Interference with MAPK and PI3K/AKT/mTOR Pathways:** **Isodeoxyelephantopin** can modulate the activity of key signaling cascades like the Mitogen-Activated Protein Kinase (MAPK) pathways (ERK, JNK, p38) and the PI3K/AKT/mTOR pathway, which are frequently dysregulated in cancer.[2][3]

Q2: What is the evidence for off-target effects of **Isodeoxyelephantopin**?

A2: The available literature suggests that **Isodeoxyelephantopin** and Deoxyelephantopin exhibit a high degree of selectivity for cancer cells over normal cells.[2][3][6] This suggests that at therapeutic concentrations, broad off-target effects leading to toxicity in normal tissues are minimal. For instance, Deoxyelephantopin showed a 30-fold higher cytotoxicity in HCT116 colon cancer cells compared to normal colon cells (CCD841CoN).[2][6] Both compounds have also been reported to be non-toxic to normal human lymphocytes at concentrations effective against cancer cells.[1][7][8] While a comprehensive screen of all potential off-target proteins (e.g., a kinome scan) is not publicly available, the current evidence points towards a favorable therapeutic window. The observed "off-target" effects are often part of the compound's intended multi-targeted, anti-cancer activity rather than unintended adverse interactions.

Q3: How can I differentiate between on-target polypharmacology and undesirable off-target effects in my experiments?

A3: Distinguishing between the desired multi-targeted effects and unwanted off-target interactions is crucial. Here are some strategies:

- **Dose-Response Analysis:** A hallmark of on-target activity is a clear dose-response relationship. Undesired off-target effects may appear only at much higher concentrations.

Comparing the IC50 values in your cancer cell line of interest with the reported values for normal cells can provide a therapeutic window.

- **Rescue Experiments:** If a specific pathway is hypothesized to be the primary target, attempting to "rescue" the phenotype by overexpressing a downstream effector or using a pathway activator can help validate the on-target effect.
- **Use of Structurally Related but Inactive Compounds:** If available, using a structurally similar analogue of **Isodeoxyelephantopin** that is known to be inactive against the primary targets can help identify non-specific effects.
- **Cell Line Comparison:** Comparing the effects of **Isodeoxyelephantopin** in a panel of cell lines with varying dependence on the hypothesized target pathways can provide evidence for on-target activity.
- **CRISPR/Cas9-mediated Gene Knockout:** To definitively validate a target, knocking out the gene encoding the putative target protein should confer resistance to the compound.[9]

Quantitative Data Summary

The following tables summarize the reported IC50 values for Deoxyelephantopin (DET) and **Isodeoxyelephantopin** (IDET) in various cancer cell lines, as well as their cytotoxicity in normal cells. This data is crucial for designing experiments with appropriate concentrations and for assessing the selectivity of the compounds.

Table 1: IC50 Values of Deoxyelephantopin (DET) in Cancer Cell Lines[2][10]

Cell Line	Cancer Type	IC50 (µg/mL)	Incubation Time (h)
HCT116	Colorectal Carcinoma	0.73	72
K562	Chronic Myeloid Leukemia	4.02	48
KB	Oral Carcinoma	3.35	48
T47D	Breast Cancer	1.86	48
A549	Lung Adenocarcinoma	12.287	Not Specified
L-929	Tumor Cell Line	11.2	Not Specified

Table 2: IC50 Values of **Isodeoxyelephantopin** (IDET) in Cancer Cell Lines[2][8]

Cell Line	Cancer Type	IC50 (µg/mL)	Incubation Time (h)
HCT116	Colorectal Carcinoma	0.88	72
A549	Lung Carcinoma	10.46	48
T47D	Breast Carcinoma	1.3	48

Table 3: Cytotoxicity Data in Normal Cells[1][2][6]

Compound	Normal Cell Line	Concentration	Observation
DET	CCD841CoN (Normal Colon)	21.69 µg/mL (72h)	Relatively low cytotoxicity
DET	Normal Human Lymphocytes	35 µg/mL	No toxicity
IDET	Normal Lymphocytes	Not Specified	Not significantly toxic

Experimental Protocols

Below are detailed methodologies for key experiments frequently performed when investigating the effects of **Isodeoxyelephantopin**.

1. Cell Viability Assay (MTT Assay)

- Objective: To determine the cytotoxic effects of **Isodeoxyelephantopin** on cancer cells.
- Methodology:
 - Seed cells (e.g., A549, T47D) in a 96-well plate at a density of 5×10^3 to 1×10^4 cells/well and allow them to adhere overnight.
 - Treat the cells with various concentrations of **Isodeoxyelephantopin** (e.g., 0.1, 1, 5, 10, 25, 50 μM) for 24, 48, or 72 hours. Include a vehicle control (e.g., DMSO).
 - After the incubation period, add 20 μL of MTT solution (5 mg/mL in PBS) to each well and incubate for 4 hours at 37°C .
 - Remove the medium and add 150 μL of DMSO to each well to dissolve the formazan crystals.
 - Measure the absorbance at 570 nm using a microplate reader.
 - Calculate the percentage of cell viability relative to the vehicle control and determine the IC50 value.

2. Western Blot Analysis for Signaling Pathway Modulation

- Objective: To assess the effect of **Isodeoxyelephantopin** on the phosphorylation status and expression levels of key proteins in signaling pathways like NF- κB , MAPK, and PI3K/AKT.
- Methodology:
 - Plate cells in 6-well plates and grow to 70-80% confluency.
 - Treat cells with **Isodeoxyelephantopin** at the desired concentration (e.g., IC50 value) for a specified time (e.g., 24 hours).
 - Lyse the cells in RIPA buffer containing protease and phosphatase inhibitors.
 - Determine the protein concentration of the lysates using a BCA assay.

- Separate equal amounts of protein (20-40 µg) by SDS-PAGE and transfer to a PVDF membrane.
- Block the membrane with 5% non-fat milk or BSA in TBST for 1 hour at room temperature.
- Incubate the membrane with primary antibodies against target proteins (e.g., phospho-p65, total p65, phospho-ERK, total ERK, phospho-AKT, total AKT, and a loading control like β-actin or GAPDH) overnight at 4°C.
- Wash the membrane and incubate with HRP-conjugated secondary antibodies for 1 hour at room temperature.
- Detect the protein bands using an enhanced chemiluminescence (ECL) detection system.

3. Reactive Oxygen Species (ROS) Detection Assay

- Objective: To measure the intracellular generation of ROS upon treatment with **Isodeoxyelephantopin**.
- Methodology:
 - Seed cells in a 96-well black plate or on coverslips in a 24-well plate.
 - Treat cells with **Isodeoxyelephantopin** for the desired time.
 - Incubate the cells with a fluorescent ROS indicator dye, such as 2',7'-dichlorodihydrofluorescein diacetate (DCFH-DA), at a final concentration of 10 µM for 30 minutes at 37°C in the dark.
 - Wash the cells with PBS to remove excess dye.
 - Measure the fluorescence intensity using a fluorescence microplate reader (excitation/emission ~485/535 nm) or visualize under a fluorescence microscope.

Troubleshooting Guides

Issue 1: High variability in IC50 values between experiments.

- Possible Causes:
 - Cell Passage Number: High passage numbers can lead to phenotypic drift and altered drug sensitivity.
 - Cell Density: Initial cell seeding density can significantly impact growth rates and drug response.
 - Compound Stability: **Isodeoxyelephantopin** in solution may degrade over time.
 - Assay-Specific Factors: Inconsistent incubation times or variations in reagent preparation.
- Solutions:
 - Use cells within a consistent and low passage number range.
 - Optimize and standardize the initial cell seeding density for each cell line.
 - Prepare fresh stock solutions of **Isodeoxyelephantopin** and store them appropriately. Aliquot single-use amounts to avoid repeated freeze-thaw cycles.
 - Ensure precise and consistent timing for all steps of the assay.

Issue 2: Unexpected or no effect on a known target pathway.

- Possible Causes:
 - Cell Line Specificity: The signaling pathways affected by **Isodeoxyelephantopin** can be cell-type specific.
 - Incorrect Concentration or Time Point: The effect on a particular pathway may be transient or require a specific concentration range.
 - Antibody Quality: Poor quality or non-specific primary antibodies in Western blotting.
- Solutions:
 - Confirm the expression and activity of the target pathway in your specific cell line.

- Perform a time-course and dose-response experiment to identify the optimal conditions for observing the effect.
- Validate your primary antibodies using positive and negative controls.

Issue 3: Observed cytotoxicity in a "normal" or non-cancerous cell line.

- Possible Causes:
 - High Compound Concentration: Even selective compounds can exhibit toxicity at very high concentrations.
 - Proliferative State of Normal Cells: Some "normal" cell lines are highly proliferative and may be more sensitive than quiescent primary cells.
 - On-Target Effect in Normal Cells: The target pathway may also be important for the viability of the specific normal cell line being used.
- Solutions:
 - Carefully review the concentrations used and compare them to the reported selective window (see Table 3).
 - If possible, use primary cells or a less proliferative normal cell line as a control.
 - Investigate whether the target pathway is active and essential in your normal cell line control.

Visualizing Signaling Pathways and Workflows

To aid in the understanding of the complex interactions of **Isodeoxyelephantopin**, the following diagrams illustrate key signaling pathways and experimental workflows.

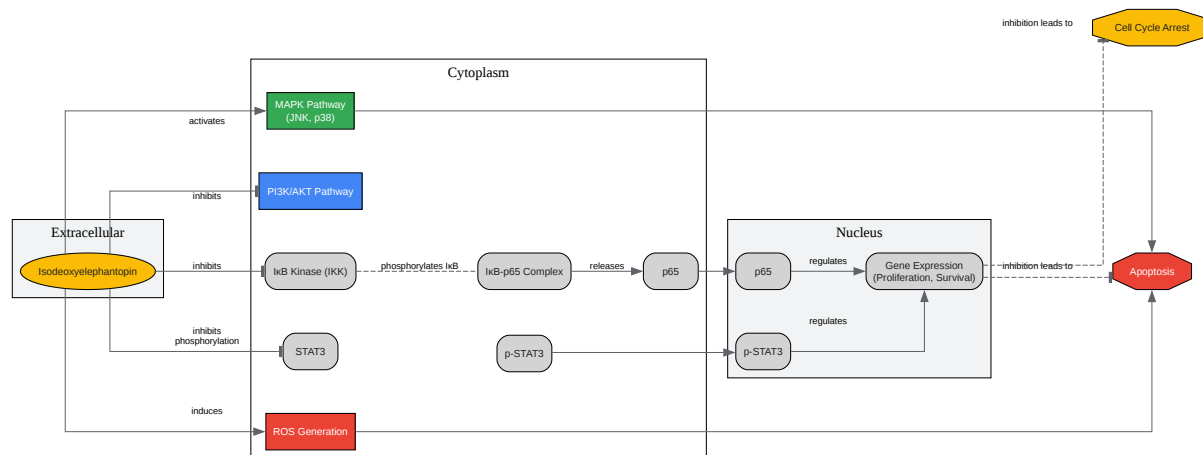

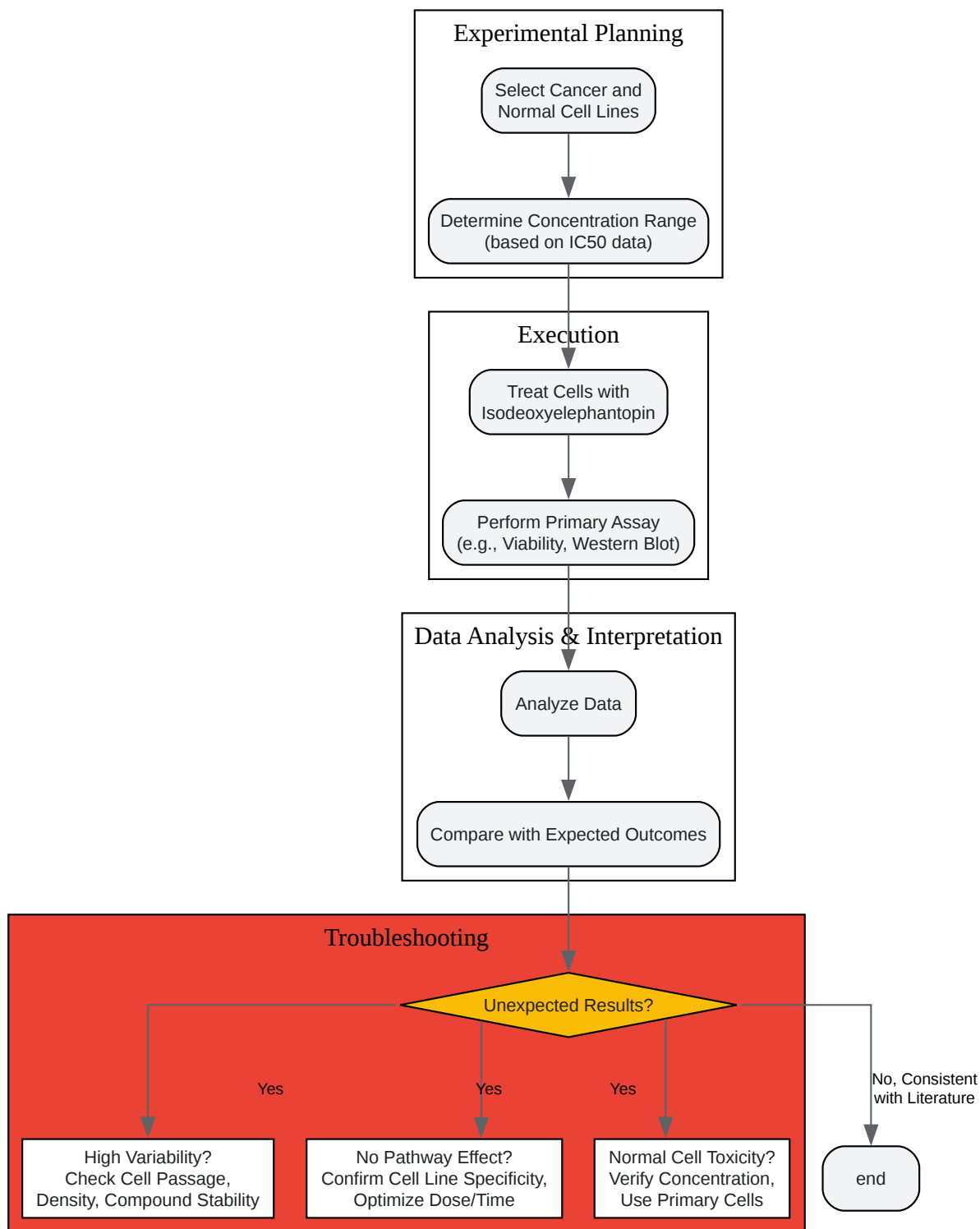

[Click to download full resolution via product page](#)

Need Custom Synthesis?

BenchChem offers custom synthesis for rare earth carbides and specific isotopic labeling.

Email: info@benchchem.com or [Request Quote Online](#).

References

- [1. jcmjournal.com](http://jcmjournal.com) [jcmjournal.com]
- [2. mdpi.com](http://mdpi.com) [mdpi.com]
- [3. Deoxyelephantopin and Isodeoxyelephantopin as Potential Anticancer Agents with Effects on Multiple Signaling Pathways - PMC](#) [pmc.ncbi.nlm.nih.gov]
- [4. mdpi.com](http://mdpi.com) [mdpi.com]
- [5. medchemexpress.com](http://medchemexpress.com) [medchemexpress.com]
- [6. researchgate.net](http://researchgate.net) [researchgate.net]
- [7. researchgate.net](http://researchgate.net) [researchgate.net]
- [8. researchgate.net](http://researchgate.net) [researchgate.net]
- [9. Off-target toxicity is a common mechanism of action of cancer drugs undergoing clinical trials - PMC](#) [pmc.ncbi.nlm.nih.gov]
- [10. Molecular mechanisms of anticancer activity of deoxyelephantopin in cancer cells - PMC](#) [pmc.ncbi.nlm.nih.gov]
- To cite this document: BenchChem. [Investigating Isodeoxyelephantopin: A Technical Support Center for Researchers]. BenchChem, [2026]. [Online PDF]. Available at: [<https://www.benchchem.com/product/b1081981/docs#investigating-isodeoxyelephantopin-a-technical-support-center-for-researchers>]

Disclaimer & Data Validity:

The information provided in this document is for Research Use Only (RUO) and is strictly not intended for diagnostic or therapeutic procedures. While BenchChem strives to provide accurate protocols, we make no warranties, express or implied, regarding the fitness of this product for every specific experimental setup.

Technical Support: The protocols provided are for reference purposes. Unsure if this reagent suits your experiment?

Need Industrial/Bulk Grade? [Request Custom Synthesis Quote](#)

BenchChem

Our mission is to be the trusted global source of essential and advanced chemicals, empowering scientists and researchers to drive progress in science and industry.

Contact

Address: 3281 E Guasti Rd
Ontario, CA 91761, United States
Phone: (601) 213-4426
Email: info@benchchem.com

[Contact our Ph.D. Support Team for a compatibility check](#)