

# Addressing HWL-088 solubility issues in aqueous solutions

**Author:** BenchChem Technical Support Team. **Date:** April 2026

## Compound of Interest

Compound Name: HWL-088  
Cat. No.: B10819329

[Get Quote](#)

## Technical Support Center: HWL-088

This technical support center provides researchers, scientists, and drug development professionals with a comprehensive guide to addressing common solubility issues encountered with **HWL-088** in aqueous solutions.

## Frequently Asked Questions (FAQs)

Q1: What is **HWL-088** and why is its solubility a concern?

A1: **HWL-088** is a potent agonist of the free fatty acid receptor 1 (FFAR1) and a moderate agonist of peroxisome proliferator-activated receptor  $\delta$  (PPAR $\delta$ ), making it a valuable tool for research in diabetes and metabolic diseases.<sup>[1][2][3][4]</sup> Structurally, it is a phenoxyacetic acid derivative, a class of compounds often characterized by low aqueous solubility.<sup>[4][5]</sup> This hydrophobicity can present challenges in preparing homogenous solutions for in vitro and in vivo experiments, potentially impacting the accuracy and reproducibility of results.

Q2: What are the initial recommended solvents for dissolving **HWL-088**?

A2: For creating stock solutions, organic solvents such as dimethyl sulfoxide (DMSO) are generally recommended for compounds with similar characteristics.[6][7][8] It is crucial to use anhydrous, high-purity DMSO as it is hygroscopic and absorbed water can reduce its solvating power.[6]

Q3: I am observing precipitation when diluting my **HWL-088** DMSO stock solution into an aqueous buffer or cell culture media. What can I do?

A3: This is a common issue known as "fall-out" that occurs when a compound that is soluble in a high-concentration organic solvent is introduced into an aqueous environment where its solubility is low.[8] To mitigate this, consider the following:

- Lower the final DMSO concentration: Aim for a final DMSO concentration of less than 0.5% in your aqueous solution to minimize solvent toxicity and precipitation.[8]
- Perform serial dilutions: Instead of a single large dilution, perform stepwise dilutions of your stock solution in the aqueous medium.[8]
- Ensure thorough mixing: Vortex or mix the solution immediately and thoroughly after adding the **HWL-088** stock to promote dispersion.[8]
- Gentle warming: Warming the aqueous medium to 37°C before adding the compound may aid in solubility.[6][8]

Q4: Are there alternative methods to enhance the aqueous solubility of **HWL-088** for my experiments?

A4: Yes, several techniques can be employed to improve the solubility of hydrophobic compounds like **HWL-088**. [7][9][10][11] These include:

- Co-solvents: Using a mixture of water and a water-miscible organic solvent can increase solubility.[7][10]
- pH adjustment: For ionizable compounds, adjusting the pH of the solution can increase solubility.[7][12]

- Use of excipients: Surfactants, cyclodextrins, and polymers can be used to create formulations that enhance solubility.[12][13][14][15] For in vivo studies with **HWL-088**, a suspension in 0.5% aqueous sodium carboxymethyl cellulose has been successfully used.[2]

## Troubleshooting Guide

This guide provides a structured approach to resolving common solubility challenges with **HWL-088**.

Problem	Potential Cause	Suggested Solution
Visible solid particles or cloudiness in the initial stock solution (e.g., in DMSO).	Insufficient mixing or sonication.	Vortex the solution vigorously for 1-2 minutes. If particles persist, sonicate in a water bath for 10-15 minutes.[6]
Low temperature.	Gently warm the solution in a 37°C water bath for 5-10 minutes.[6][8]	
Hygroscopic DMSO.	Use a fresh, unopened bottle of anhydrous, high-purity DMSO.[6]	
Compound precipitates out of solution upon dilution into aqueous media.	Rapid change in solvent polarity.	Perform serial dilutions of the DMSO stock solution into the aqueous buffer.[8]
Final concentration exceeds aqueous solubility.	Reduce the final concentration of HWL-088 in the aqueous solution.	
Insufficient mixing.	Ensure immediate and thorough vortexing or mixing after dilution.[8]	
Inconsistent experimental results.	Inhomogeneous solution due to poor solubility.	Before each experiment, visually inspect the solution for any precipitation. If necessary, briefly sonicate or vortex the solution.
Compound degradation.	Verify the purity and integrity of your HWL-088 stock using analytical methods like HPLC or LC-MS.[6] Chemical stability in the dissolution medium can be a factor.[16][17]	

## Experimental Protocols

### Protocol 1: Preparation of a 10 mM HWL-088 Stock Solution in DMSO

- Weighing: Accurately weigh the required amount of **HWL-088** powder.
- Solvent Addition: Add the calculated volume of high-purity, anhydrous DMSO to achieve a 10 mM concentration.
- Dissolution:
  - Cap the vial tightly and vortex vigorously for 1-2 minutes.
  - Visually inspect for any undissolved particles.
  - If necessary, place the vial in a water bath sonicator for 10-15 minutes.[\[6\]](#)
  - Gentle warming to 37°C for 5-10 minutes can also be applied if sonication is insufficient.[\[6\]](#)  
[\[8\]](#)
- Storage: Once fully dissolved, store the stock solution at -20°C or -80°C, protected from light and moisture. Aliquoting into smaller, single-use volumes is recommended to avoid repeated freeze-thaw cycles.[\[8\]](#)

### Protocol 2: Preparation of an Aqueous Working Solution from a DMSO Stock

- Pre-warm Medium: Warm the aqueous buffer or cell culture medium to 37°C.
- Calculate Dilution: Determine the volume of the DMSO stock solution needed to achieve the desired final concentration of **HWL-088**. Ensure the final DMSO concentration remains below 0.5%.
- Serial Dilution (Recommended):
  - Prepare an intermediate dilution of the DMSO stock in the aqueous medium.

- Add the intermediate dilution to the final volume of the pre-warmed aqueous medium.
- Mixing: Immediately after adding the **HWL-088** solution, vortex or mix thoroughly to ensure homogeneity.
- Visual Inspection: Before use, visually inspect the final working solution to ensure it is clear and free of any visible precipitate.

## Visualizations

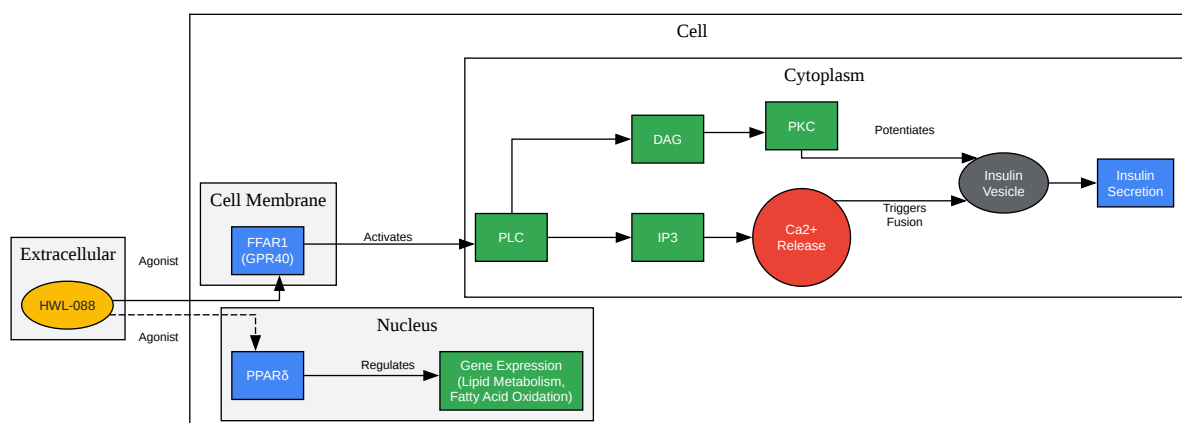

[Click to download full resolution via product page](#)

Caption: Signaling pathway of **HWL-088** as a dual agonist for FFAR1 and PPAR $\delta$ .

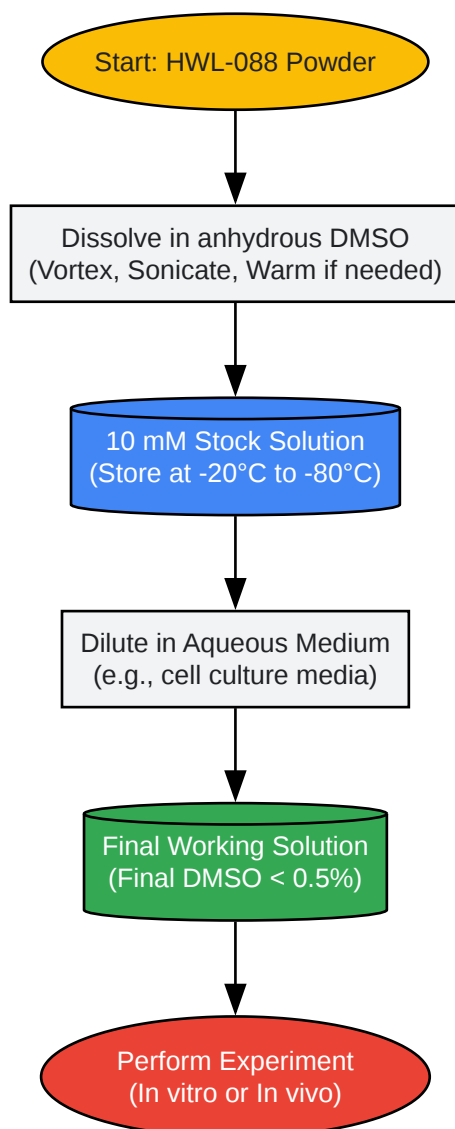

[Click to download full resolution via product page](#)

Caption: Experimental workflow for preparing **HWL-088** solutions.

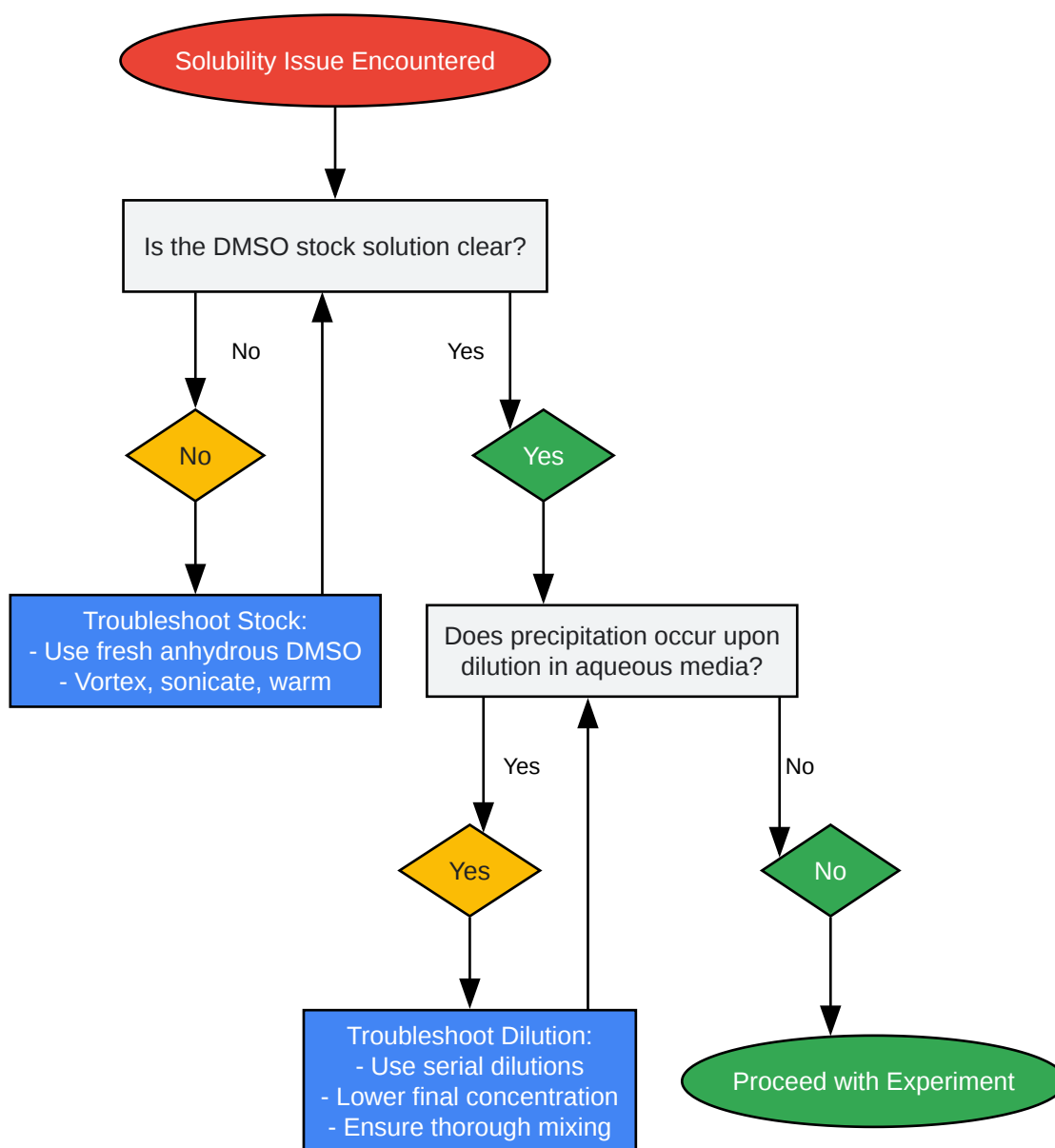

[Click to download full resolution via product page](#)

Caption: Logical workflow for troubleshooting **HWL-088** solubility issues.

### *Need Custom Synthesis?*

*BenchChem offers custom synthesis for rare earth carbides and specific isotopic labeling.*

*Email: [info@benchchem.com](mailto:info@benchchem.com) or [Request Quote Online](#).*

## References

- 1. HWL-088, a new potent free fatty acid receptor 1 (FFAR1) agonist, improves glucolipid metabolism and acts additively with metformin in ob/ob diabetic mice - PubMed [[pubmed.ncbi.nlm.nih.gov](https://pubmed.ncbi.nlm.nih.gov)]
- 2. HWL-088, a new potent free fatty acid receptor 1 (FFAR1) agonist, improves glucolipid metabolism and acts additively with metformin in ob/ob diabetic mice - PMC [[pmc.ncbi.nlm.nih.gov](https://pmc.ncbi.nlm.nih.gov)]
- 3. [researchgate.net](https://researchgate.net) [[researchgate.net](https://researchgate.net)]
- 4. Discovery of HWL-088: A highly potent FFA1/GPR40 agonist bearing a phenoxyacetic acid scaffold - PubMed [[pubmed.ncbi.nlm.nih.gov](https://pubmed.ncbi.nlm.nih.gov)]
- 5. [researchgate.net](https://researchgate.net) [[researchgate.net](https://researchgate.net)]
- 6. [benchchem.com](https://benchchem.com) [[benchchem.com](https://benchchem.com)]
- 7. [wjbphs.com](https://wjbphs.com) [[wjbphs.com](https://wjbphs.com)]
- 8. [benchchem.com](https://benchchem.com) [[benchchem.com](https://benchchem.com)]
- 9. [researchgate.net](https://researchgate.net) [[researchgate.net](https://researchgate.net)]
- 10. [asiapharmaceutics.info](https://asiapharmaceutics.info) [[asiapharmaceutics.info](https://asiapharmaceutics.info)]
- 11. [japer.in](https://japer.in) [[japer.in](https://japer.in)]
- 12. [senpharma.vn](https://senpharma.vn) [[senpharma.vn](https://senpharma.vn)]
- 13. [pubs.acs.org](https://pubs.acs.org) [[pubs.acs.org](https://pubs.acs.org)]
- 14. [researchgate.net](https://researchgate.net) [[researchgate.net](https://researchgate.net)]
- 15. SPECIAL FEATURE - Excipients: Enhancing the New, Poorly Soluble APIs [[drug-dev.com](https://drug-dev.com)]
- 16. [dissolutiontech.com](https://dissolutiontech.com) [[dissolutiontech.com](https://dissolutiontech.com)]
- 17. [dissolutiontech.com](https://dissolutiontech.com) [[dissolutiontech.com](https://dissolutiontech.com)]
- To cite this document: BenchChem. [Addressing HWL-088 solubility issues in aqueous solutions]. BenchChem, [2026]. [Online PDF]. Available at: [<https://www.benchchem.com/product/b10819329/docs#addressing-hwl-088-solubility-issues-in-aqueous-solutions>]

---

### Disclaimer & Data Validity:

The information provided in this document is for Research Use Only (RUO) and is strictly not intended for diagnostic or therapeutic procedures. While BenchChem strives to provide

accurate protocols, we make no warranties, express or implied, regarding the fitness of this product for every specific experimental setup.

**Technical Support:** The protocols provided are for reference purposes. Unsure if this reagent suits your experiment?

**Need Industrial/Bulk Grade?** [Request Custom Synthesis Quote](#)

## BenchChem

Our mission is to be the trusted global source of essential and advanced chemicals, empowering scientists and researchers to drive progress in science and industry.

### Contact

Address: 3281 E Guasti Rd

Ontario, CA 91761, United States

Phone: (601) 213-4426

Email: [info@benchchem.com](mailto:info@benchchem.com)

[Contact our Ph.D. Support Team for a compatibility check](#)