

troubleshooting GNE-207 experimental variability

Author: BenchChem Technical Support Team. **Date:** April 2026

Compound of Interest

Compound Name: GNE-207
Cat. No.: B10818736

[Get Quote](#)

GNE-207 Technical Support Center

This technical support center provides troubleshooting guidance and frequently asked questions (FAQs) for researchers using the CBP bromodomain inhibitor, **GNE-207**.

Frequently Asked Questions (FAQs)

Q1: What is **GNE-207** and what is its primary mechanism of action?

GNE-207 is a potent, selective, and orally bioavailable small molecule inhibitor of the bromodomain of the CREB-binding protein (CBP).^{[1][2][3][4][5]} Its primary mechanism of action is to competitively bind to the acetyl-lysine binding pocket of the CBP bromodomain, thereby preventing its interaction with acetylated histone and non-histone proteins. This inhibition disrupts the recruitment of CBP to chromatin and subsequently downregulates the expression of target genes, such as MYC.^{[1][3][4]}

Q2: What are the key in vitro and in vivo activities of **GNE-207**?

The following table summarizes the key quantitative data for **GNE-207**:

Parameter	Value	Cell Line/System	Reference
CBP Bromodomain IC50	1 nM	Biochemical Assay	[1][2][3][4][5]
BRD4(1) IC50	3.1 μ M	Biochemical Assay	[2][4]
MYC Expression EC50	18 nM	MV-4-11 cells	[1][2][3][4][5]
In vivo Administration	5 mg/kg	Mouse	[1][4]

Q3: How should I prepare and store **GNE-207** stock solutions?

For in vitro experiments, it is recommended to first prepare a clear stock solution in a solvent like DMSO.[1][3] For in vivo studies, the stock solution can be further diluted in appropriate vehicles.[3] It is crucial to ensure complete dissolution; sonication or gentle heating may be used if precipitation occurs.[3][6] Stock solutions should be stored at -20°C or -80°C and aliquoted to avoid repeated freeze-thaw cycles.[1][3] For in vivo working solutions, fresh preparation on the day of use is recommended.[3][6]

Troubleshooting Experimental Variability

Q4: I am observing inconsistent results in my cell-based assays with **GNE-207**. What are the potential causes and solutions?

Inconsistent results in cell-based assays can arise from several factors. Here are some common issues and troubleshooting tips:

Potential Cause	Troubleshooting Suggestions
Compound Precipitation	<ul style="list-style-type: none">- Visually inspect the media for any precipitate after adding GNE-207. - Prepare fresh dilutions from a clear stock solution for each experiment.- Consider using a lower concentration of GNE-207 or a different solvent system if precipitation persists.
Cell Health and Density	<ul style="list-style-type: none">- Ensure cells are healthy and in the logarithmic growth phase before treatment. - Maintain consistent cell seeding density across all experiments, as this can influence drug response.
Assay Timing	<ul style="list-style-type: none">- Optimize the incubation time with GNE-207. The effect on gene expression and cell viability can be time-dependent.
Inconsistent Drug Concentration	<ul style="list-style-type: none">- Use calibrated pipettes and ensure accurate dilutions of the stock solution.
Mycoplasma Contamination	<ul style="list-style-type: none">- Regularly test cell cultures for mycoplasma contamination, which can alter cellular responses to treatments.

Q5: My Western blot results for downstream targets of CBP are not showing the expected changes after **GNE-207** treatment. What should I check?

Potential Cause	Troubleshooting Suggestions
Suboptimal GNE-207 Concentration or Incubation Time	- Perform a dose-response and time-course experiment to determine the optimal concentration and duration of GNE-207 treatment for your specific cell line and target protein.
Poor Antibody Quality	- Validate the primary antibody to ensure it is specific for the target protein and provides a robust signal.
Inefficient Protein Extraction	- Use an appropriate lysis buffer containing protease and phosphatase inhibitors to ensure protein integrity.
Protein Loading and Transfer Issues	- Quantify protein concentration before loading to ensure equal loading across lanes. - Verify efficient protein transfer from the gel to the membrane using a total protein stain like Ponceau S.
Cell Line Specific Effects	- The regulation of your target protein may be complex and not solely dependent on CBP activity in your chosen cell line. Consider using a positive control cell line where the effect of CBP inhibition on your target is established.

Signaling Pathways and Experimental Workflows

CBP/p300 Signaling Pathway

The diagram below illustrates the central role of CBP/p300 as a transcriptional co-activator in multiple signaling pathways. **GNE-207** inhibits the bromodomain of CBP, thereby disrupting its interaction with acetylated proteins and modulating gene expression.

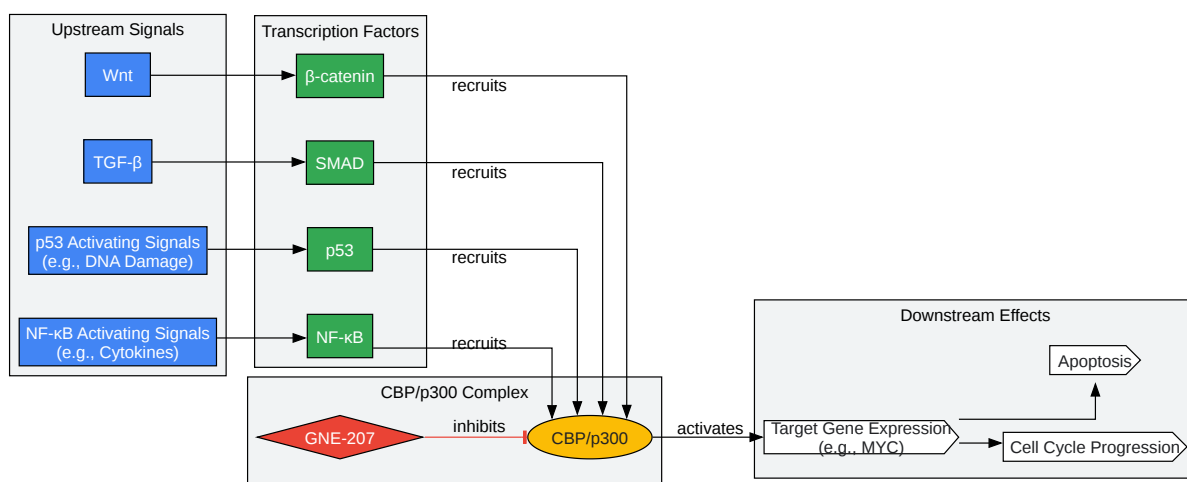

[Click to download full resolution via product page](#)

Caption: **GNE-207** inhibits the CBP bromodomain, affecting multiple signaling pathways.

General Experimental Workflow for Assessing **GNE-207** Activity

The following workflow outlines the key steps to evaluate the cellular effects of **GNE-207**.

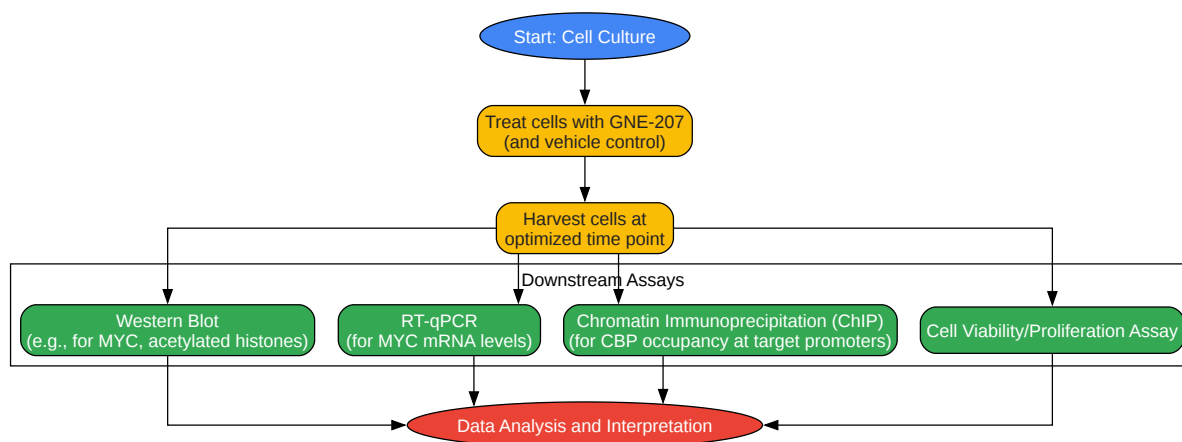

[Click to download full resolution via product page](#)

Caption: A typical workflow for studying the effects of **GNE-207** on cultured cells.

Detailed Experimental Protocols

Western Blot Analysis of MYC Protein Levels

- Cell Lysis:
 - After treatment with **GNE-207** or vehicle, wash cells with ice-cold PBS.
 - Lyse cells in RIPA buffer supplemented with protease and phosphatase inhibitors.
 - Scrape adherent cells and collect the lysate. For suspension cells, pellet and resuspend in lysis buffer.
 - Centrifuge the lysate to pellet cell debris and collect the supernatant.

- Protein Quantification:
 - Determine the protein concentration of each lysate using a BCA or Bradford assay.
- Sample Preparation and Electrophoresis:
 - Normalize protein concentrations for all samples.
 - Add Laemmli sample buffer and boil at 95-100°C for 5 minutes.
 - Load equal amounts of protein per lane on an SDS-PAGE gel.
- Protein Transfer:
 - Transfer proteins from the gel to a PVDF or nitrocellulose membrane.
- Immunoblotting:
 - Block the membrane with 5% non-fat dry milk or BSA in TBST for 1 hour at room temperature.
 - Incubate the membrane with a primary antibody against MYC (and a loading control like β -actin or GAPDH) overnight at 4°C.
 - Wash the membrane with TBST.
 - Incubate with an appropriate HRP-conjugated secondary antibody for 1 hour at room temperature.
 - Wash the membrane again with TBST.
- Detection:
 - Detect the signal using an enhanced chemiluminescence (ECL) substrate and image the blot.

Chromatin Immunoprecipitation (ChIP) for CBP Occupancy

- Cross-linking:

- Treat cells with **GNE-207** or vehicle.
- Add formaldehyde to a final concentration of 1% to cross-link proteins to DNA and incubate for 10 minutes at room temperature.
- Quench the cross-linking reaction with glycine.
- Cell Lysis and Chromatin Shearing:
 - Wash cells with cold PBS and harvest.
 - Lyse cells to release nuclei.
 - Resuspend nuclei in a shearing buffer and sonicate to shear chromatin to fragments of 200-1000 bp.
- Immunoprecipitation:
 - Pre-clear the chromatin with protein A/G agarose/magnetic beads.
 - Incubate the chromatin with an antibody against CBP (or a negative control IgG) overnight at 4°C.
 - Add protein A/G beads to pull down the antibody-protein-DNA complexes.
- Washes and Elution:
 - Wash the beads sequentially with low salt, high salt, LiCl, and TE buffers to remove non-specific binding.
 - Elute the chromatin from the beads.
- Reverse Cross-linking and DNA Purification:
 - Reverse the formaldehyde cross-links by incubating at 65°C with NaCl.
 - Treat with RNase A and Proteinase K.
 - Purify the DNA using a PCR purification kit or phenol-chloroform extraction.

- Analysis:
 - Quantify the immunoprecipitated DNA using qPCR with primers specific for the promoter region of a known CBP target gene (e.g., MYC).

Need Custom Synthesis?

BenchChem offers custom synthesis for rare earth carbides and specific isotopic labeling.

Email: info@benchchem.com or [Request Quote Online](#).

References

- [1. Targeting CBP and p300: Emerging Anticancer Agents \[mdpi.com\]](#)
- [2. The transcriptional co-activators CBP and p300 are activated via phenylephrine through the p42/p44 MAPK cascade - PubMed \[pubmed.ncbi.nlm.nih.gov\]](#)
- [3. medchemexpress.com \[medchemexpress.com\]](#)
- [4. cancer-research-network.com \[cancer-research-network.com\]](#)
- [5. glpbio.com \[glpbio.com\]](#)
- [6. medchemexpress.com \[medchemexpress.com\]](#)
- [To cite this document: BenchChem. \[troubleshooting GNE-207 experimental variability\]. BenchChem, \[2026\]. \[Online PDF\]. Available at: \[https://www.benchchem.com/product/b10818736/docs#troubleshooting-gne-207-experimental-variability\]](#)

Disclaimer & Data Validity:

The information provided in this document is for Research Use Only (RUO) and is strictly not intended for diagnostic or therapeutic procedures. While BenchChem strives to provide accurate protocols, we make no warranties, express or implied, regarding the fitness of this product for every specific experimental setup.

Technical Support: The protocols provided are for reference purposes. Unsure if this reagent suits your experiment?

Need Industrial/Bulk Grade? [Request Custom Synthesis Quote](#)

BenchChem

Our mission is to be the trusted global source of essential and advanced chemicals, empowering scientists and researchers to drive progress in science and industry.

Contact

Address: 3281 E Guasti Rd
Ontario, CA 91761, United States
Phone: (601) 213-4426
Email: info@benchchem.com

[Contact our Ph.D. Support Team for a compatibility check](#)