

# Validating PD-L1 Target Engagement of BMS-1166 in Cells: A Comparative Guide

**Author:** BenchChem Technical Support Team. **Date:** April 2026

## Compound of Interest

Compound Name: *BMS-1166 hydrochloride*

Cat. No.: *B10818828*

[Get Quote](#)

For Researchers, Scientists, and Drug Development Professionals

This guide provides a comprehensive comparison of cellular methods to validate the target engagement of BMS-1166, a small-molecule inhibitor of the programmed death-ligand 1 (PD-L1). We will explore its performance in context with alternative PD-L1 inhibitors, including other small molecules and therapeutic monoclonal antibodies, supported by experimental data and detailed protocols.

## Introduction to BMS-1166 and its Mechanism of Action

BMS-1166 is a potent small-molecule inhibitor that disrupts the interaction between PD-1 and its ligand, PD-L1, a critical immune checkpoint pathway that tumor cells exploit to evade immune surveillance. Unlike monoclonal antibodies that sterically hinder the PD-1/PD-L1 interaction at the cell surface, BMS-1166 boasts a dual mechanism of action. Not only does it induce the dimerization of PD-L1 to block the binding to PD-1, but it also uniquely interferes with the post-translational modification of PD-L1. Specifically, BMS-1166 inhibits the glycosylation of PD-L1 and prevents its transport from the endoplasmic reticulum (ER) to the Golgi apparatus, leading to the accumulation of an under-glycosylated form of PD-L1 in the ER.

[1][2] This intracellular sequestration further reduces the amount of functional PD-L1 on the cell surface available to engage with PD-1 on T cells.

## Comparative Analysis of Cellular Target Engagement

Validating the cellular target engagement of BMS-1166 and comparing its efficacy to other inhibitors is crucial for preclinical development. This can be achieved through various in vitro cellular assays. Below, we compare the performance of BMS-1166 with other small-molecule inhibitors and monoclonal antibodies in key cellular assays.

### Data Presentation

Table 1: Comparison of Inhibitor Potency in a PD-1/PD-L1 Blockade Reporter Assay

This assay typically utilizes a co-culture system of PD-L1-expressing cells and PD-1-expressing Jurkat T cells engineered with a reporter gene (e.g., luciferase) under the control of an NFAT response element. Inhibition of the PD-1/PD-L1 interaction relieves T-cell suppression and leads to a measurable reporter signal.

Compound/Antibody	Type	Cellular EC50 (nM)	Notes
BMS-1166	Small Molecule	~276 - 83.4	Potency can vary based on the specific reporter cell line and assay conditions.[3][4]
BMS-1001	Small Molecule	Three-digit nM range	Less potent than monoclonal antibodies in this assay format.[5]
ARB-272572	Small Molecule	17	Demonstrates potent cellular activity.[6][7]
INCB086550	Small Molecule	3.67 ± 1.21	Clinically evaluated small-molecule inhibitor.[8]
Evixapodlin (CA-170)	Small Molecule	>4000	Shows weak or no direct activity in some cellular reporter assays.[4][8]
Nivolumab (anti-PD-1)	Monoclonal Antibody	0.333 - 1.15	High potency typical for therapeutic antibodies.[5]
Pembrolizumab (anti-PD-1)	Monoclonal Antibody	0.333 - 1.15	High potency typical for therapeutic antibodies.[5]
Atezolizumab (anti-PD-L1)	Monoclonal Antibody	0.333 - 1.15	High potency typical for therapeutic antibodies.[5]
Durvalumab (anti-PD-L1)	Monoclonal Antibody	0.2 ± 0.06 - 1.15	High potency typical for therapeutic antibodies.[5][8]

Note: EC50 values are compiled from multiple sources and should be interpreted with caution due to potential variations in experimental setups.[\[3\]](#)[\[4\]](#)[\[5\]](#)[\[6\]](#)[\[7\]](#)[\[8\]](#)

Table 2: Overview of Cellular Assays for PD-L1 Target Engagement

Assay	Principle	Readout	Advantages	Disadvantages
PD-1/PD-L1 Blockade Reporter Assay	Co-culture of PD-L1+ cells and PD-1+/NFAT-reporter T cells. Blockade of PD-1/PD-L1 interaction activates T cells and reporter gene expression.	Luminescence, Fluorescence	High-throughput, quantitative, mechanism-based.	Uses engineered cell lines which may not fully recapitulate primary immune cell responses.
Co-culture T-cell Activation Assay	Co-culture of PD-L1+ tumor cells with primary T cells or a T cell line (e.g., Jurkat).	Cytokine secretion (e.g., IFN- $\gamma$ , IL-2) measured by ELISA; T-cell proliferation; Expression of activation markers (e.g., CD25, CD69) by flow cytometry.	More physiologically relevant with primary cells, multiple readout options.	Lower throughput, higher variability with primary cells.
Cellular Thermal Shift Assay (CETSA)	Ligand binding to a target protein alters its thermal stability.	Western Blot or other protein detection methods to quantify soluble protein after heat treatment.	Directly confirms target engagement in a cellular environment without modifying the compound or protein.	Lower throughput for Western Blot-based detection, some compounds may not induce a thermal shift.
PD-1 Degradation Assay	Co-culture of PD-L1+ cells and PD-1+ cells. Engagement of PD-L1 induces	Western Blot to quantify PD-1 protein levels.	Provides a direct measure of the consequence of PD-L1 engagement.	Lower throughput, indirect measure of inhibitor activity.

PD-1  
degradation.

---

## Experimental Protocols

### Protocol 1: PD-1/PD-L1 Blockade Reporter Gene Assay

This protocol is adapted from commercially available bioassays and published literature.<sup>[5]</sup>

Materials:

- PD-L1 expressing cells (e.g., CHO-K1 stably expressing human PD-L1 and a T-cell receptor activator).
- PD-1 Effector cells (e.g., Jurkat cells stably expressing human PD-1 and an NFAT-luciferase reporter).
- Cell culture medium (e.g., RPMI-1640 with 10% FBS).
- BMS-1166 and other inhibitors.
- 96-well white, clear-bottom assay plates.
- Luciferase assay reagent.
- Luminometer.

Procedure:

- Seed PD-L1 expressing cells in a 96-well plate at a density optimized for T-cell stimulation.
- Prepare serial dilutions of BMS-1166 and other inhibitors in cell culture medium. Add the diluted compounds to the wells. Include a vehicle control (e.g., DMSO).
- Add the PD-1 Effector T-cells to the wells.
- Incubate the co-culture plate at 37°C in a 5% CO<sub>2</sub> incubator for 6-24 hours to allow for T-cell activation and luciferase expression.

- Add the luciferase assay reagent to each well according to the manufacturer's instructions.
- Measure the luminescence using a luminometer.
- Calculate EC50 values by plotting the luminescence signal against the logarithm of the inhibitor concentration.

## Protocol 2: Co-culture T-cell Activation Assay with Flow Cytometry Readout

This protocol is a generalized procedure for assessing T-cell activation markers.

Materials:

- PD-L1 expressing tumor cells (e.g., MDA-MB-231).
- Human Peripheral Blood Mononuclear Cells (PBMCs) or a T-cell line (e.g., Jurkat).
- Cell culture medium (e.g., RPMI-1640 with 10% FBS).
- BMS-1166 and other inhibitors.
- Anti-CD3 and Anti-CD28 antibodies (for T-cell stimulation).
- Fluorochrome-conjugated antibodies against T-cell activation markers (e.g., anti-CD25, anti-CD69).
- Flow cytometer.

Procedure:

- Seed PD-L1 expressing tumor cells in a culture plate. If endogenous PD-L1 expression is low, it can be induced by treating with IFN- $\gamma$  for 24-48 hours.
- Isolate T-cells from PBMCs if using primary cells.
- Add T-cells to the tumor cell culture at a desired effector-to-target ratio (e.g., 10:1).

- Add BMS-1166 or other inhibitors at various concentrations. Include appropriate controls (e.g., vehicle, isotype control for antibody inhibitors).
- Add stimulating agents like anti-CD3/anti-CD28 antibodies if required.
- Co-culture for 24-72 hours at 37°C in a 5% CO<sub>2</sub> incubator.
- Harvest the T-cells and stain with fluorochrome-conjugated antibodies against activation markers.
- Analyze the expression of activation markers on T-cells using a flow cytometer.

## Protocol 3: Cellular Thermal Shift Assay (CETSA) for PD-L1

This protocol outlines a Western Blot-based CETSA to confirm direct binding of BMS-1166 to PD-L1 in cells.

Materials:

- Cells expressing PD-L1 (e.g., H820 or MDA-MB-231).
- BMS-1166.
- PBS and protease inhibitors.
- Lysis buffer.
- Thermocycler.
- Apparatus for SDS-PAGE and Western Blotting.
- Anti-PD-L1 antibody.
- Secondary antibody and detection reagents.

Procedure:

- Culture PD-L1 expressing cells and treat with either BMS-1166 or vehicle (DMSO) for a specified time (e.g., 1-2 hours) at 37°C.
- Harvest the cells and wash with PBS.
- Resuspend the cell pellets in PBS with protease inhibitors.
- Aliquot the cell suspension into PCR tubes.
- Heat the tubes at a range of temperatures (e.g., 40°C to 70°C) for 3 minutes in a thermocycler, followed by cooling for 3 minutes at room temperature.
- Lyse the cells by freeze-thaw cycles or by adding lysis buffer.
- Separate the soluble fraction (containing non-denatured protein) from the precipitated protein by centrifugation at high speed (e.g., 20,000 x g) for 20 minutes at 4°C.
- Collect the supernatant and determine the protein concentration.
- Analyze equal amounts of protein from each sample by SDS-PAGE and Western Blotting using an anti-PD-L1 antibody.
- A shift in the temperature at which PD-L1 aggregates in the presence of BMS-1166 compared to the vehicle control indicates target engagement.

## Mandatory Visualization

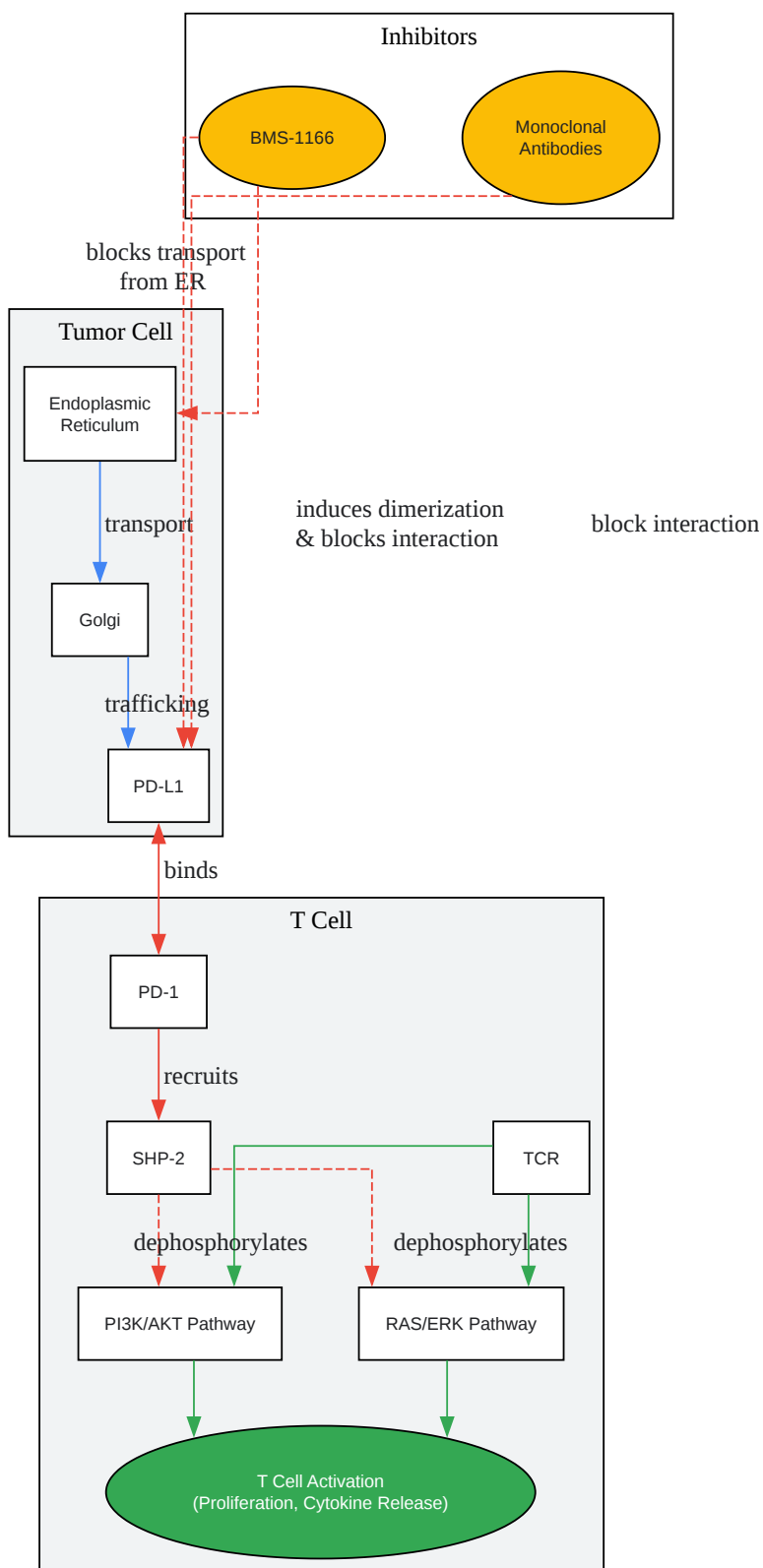

[Click to download full resolution via product page](#)

Caption: PD-1/PD-L1 signaling and points of intervention by inhibitors.

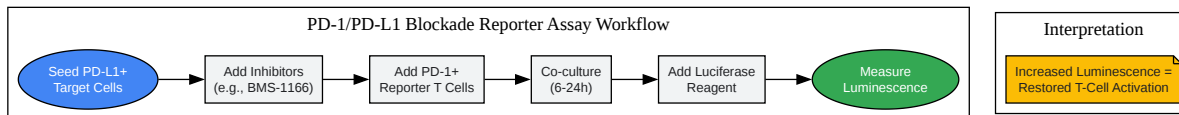

[Click to download full resolution via product page](#)

Caption: Workflow of a PD-1/PD-L1 blockade reporter gene assay.

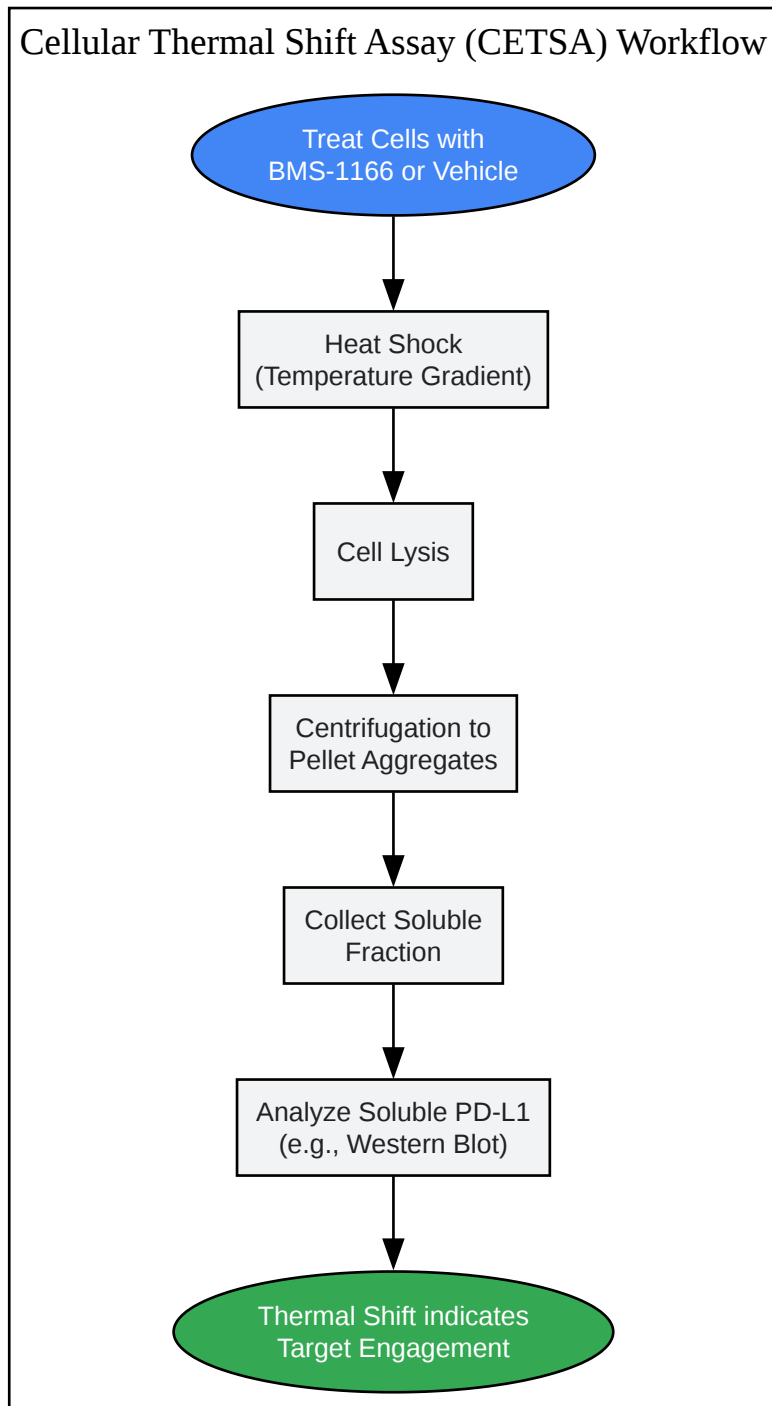

[Click to download full resolution via product page](#)

Caption: General workflow for a Cellular Thermal Shift Assay (CETSA).

### Need Custom Synthesis?

BenchChem offers custom synthesis for rare earth carbides and specific isotopic labeling.

Email: [info@benchchem.com](mailto:info@benchchem.com) or [Request Quote Online](#).

## References

- 1. Small-molecule PD-L1 inhibitor BMS1166 abrogates the function of PD-L1 by blocking its ER export - PMC [[pmc.ncbi.nlm.nih.gov](https://pubmed.ncbi.nlm.nih.gov/)]
- 2. Small-molecule PD-L1 inhibitor BMS1166 abrogates the function of PD-L1 by blocking its ER export - PubMed [[pubmed.ncbi.nlm.nih.gov](https://pubmed.ncbi.nlm.nih.gov/)]
- 3. [pdfs.semanticscholar.org](https://pdfs.semanticscholar.org/) [[pdfs.semanticscholar.org](https://pdfs.semanticscholar.org/)]
- 4. [repositorium.meduniwien.ac.at](https://repositorium.meduniwien.ac.at/) [[repositorium.meduniwien.ac.at](https://repositorium.meduniwien.ac.at/)]
- 5. Small-molecule inhibitors of PD-1/PD-L1 immune checkpoint alleviate the PD-L1-induced exhaustion of T-cells - PMC [[pmc.ncbi.nlm.nih.gov](https://pubmed.ncbi.nlm.nih.gov/)]
- 6. Small Molecule Agents Targeting PD-1 Checkpoint Pathway for Cancer Immunotherapy: Mechanisms of Action and Other Considerations for Their Advanced Development - PMC [[pmc.ncbi.nlm.nih.gov](https://pubmed.ncbi.nlm.nih.gov/)]
- 7. [medchemexpress.com](https://medchemexpress.com/) [[medchemexpress.com](https://medchemexpress.com/)]
- 8. [pubs.acs.org](https://pubs.acs.org/) [[pubs.acs.org](https://pubs.acs.org/)]
- To cite this document: BenchChem. [Validating PD-L1 Target Engagement of BMS-1166 in Cells: A Comparative Guide]. BenchChem, [2026]. [Online PDF]. Available at: [<https://www.benchchem.com/product/b10818828/docs#validating-pd-l1-target-engagement-of-bms-1166-in-cells-a-comparative-guide>]

---

### Disclaimer & Data Validity:

The information provided in this document is for Research Use Only (RUO) and is strictly not intended for diagnostic or therapeutic procedures. While BenchChem strives to provide accurate protocols, we make no warranties, express or implied, regarding the fitness of this product for every specific experimental setup.

**Technical Support:** The protocols provided are for reference purposes. Unsure if this reagent suits your experiment?

**Need Industrial/Bulk Grade?** [Request Custom Synthesis Quote](#)

## BenchChem

Our mission is to be the trusted global source of essential and advanced chemicals, empowering scientists and researchers to drive progress in science and industry.

### Contact

Address: 3281 E Guasti Rd  
Ontario, CA 91761, United States  
Phone: (601) 213-4426  
Email: [info@benchchem.com](mailto:info@benchchem.com)

[Contact our Ph.D. Support Team for a compatibility check](#)