

T-448 Experimental Results: Technical Support Center

Author: BenchChem Technical Support Team. **Date:** April 2026

Compound of Interest

Compound Name: T-448
Cat. No.: B10818703

[Get Quote](#)

This technical support center provides troubleshooting guides and frequently asked questions (FAQs) to help researchers, scientists, and drug development professionals address common issues encountered during experiments with the experimental kinase inhibitor **T-448**. **T-448** is a potent and selective inhibitor of the PI3K/Akt/mTOR signaling pathway, a critical regulator of cell growth, proliferation, and survival that is often dysregulated in cancer.^{[1][2][3][4]}

Frequently Asked Questions (FAQs)

Q1: What is the mechanism of action for **T-448**?

A1: **T-448** is an ATP-competitive kinase inhibitor that targets the p110 catalytic subunit of Phosphoinositide 3-kinase (PI3K). By inhibiting PI3K, **T-448** prevents the phosphorylation of phosphatidylinositol 4,5-bisphosphate (PIP2) to phosphatidylinositol 3,4,5-trisphosphate (PIP3). This, in turn, blocks the recruitment and activation of downstream effectors such as Akt and mTOR, leading to the inhibition of cell proliferation and induction of apoptosis in cancer cells with a hyperactivated PI3K/Akt/mTOR pathway.^{[1][3]}

Q2: In which cancer cell lines is **T-448** expected to be most effective?

A2: **T-448** is most effective in cancer cell lines harboring genetic alterations that lead to the hyperactivation of the PI3K/Akt/mTOR pathway.[2] This includes cells with activating mutations in the PIK3CA gene or loss-of-function mutations in the PTEN tumor suppressor gene.[2][3] Efficacy should be confirmed in your specific cell line of interest.

Q3: What are the recommended storage conditions for **T-448**?

A3: **T-448** is supplied as a lyophilized powder. For long-term storage, it is recommended to store the powder at -20°C. For short-term use, a stock solution can be prepared in DMSO and stored at -20°C or -80°C. Avoid repeated freeze-thaw cycles.

Troubleshooting Guides

Cell Viability Assays (e.g., MTT, MTS, CellTiter-Glo®)

Issue 1: High variability between replicate wells.

- Possible Causes & Solutions:
 - Uneven cell seeding: Ensure a homogenous single-cell suspension before plating.
 - Incomplete dissolution of **T-448**: Prepare a concentrated stock solution in DMSO and vortex thoroughly before diluting it in the culture medium.
 - Edge effects: Avoid using the outermost wells of the plate for experimental conditions, as evaporation can concentrate media components. Fill these wells with sterile PBS or media.[5]

Issue 2: No dose-dependent decrease in cell viability.

- Possible Causes & Solutions:
 - Cell line resistance: The chosen cell line may not have a constitutively active PI3K/Akt/mTOR pathway. Confirm the pathway's activation status via Western blot.
 - Incorrect assay endpoint: The incubation time may be too short. Perform a time-course experiment (e.g., 24, 48, 72 hours) to determine the optimal treatment duration.

- Assay insensitivity: The chosen assay may not be sensitive enough. Consider using a more sensitive method, such as an ATP-based luminescent assay (e.g., CellTiter-Glo®).[5]
- Compound degradation: Ensure that **T-448** has been stored correctly and that stock solutions are not expired.

Western Blotting

Issue 3: Weak or no signal for phosphorylated Akt (p-Akt) or phosphorylated S6 ribosomal protein (p-S6).

- Possible Causes & Solutions:
 - Low target protein abundance: Ensure you are loading a sufficient amount of protein per well (20-30 µg is a good starting point).
 - Suboptimal antibody concentration: Titrate your primary antibody to determine the optimal concentration. Increase the incubation time (e.g., overnight at 4°C).
 - Inefficient protein transfer: Verify transfer efficiency by staining the membrane with Ponceau S before blocking.[6]
 - Phosphatase activity: Ensure that phosphatase inhibitors are included in your lysis buffer.
 - Basal pathway activity is low: In some cell lines, the pathway may need to be stimulated (e.g., with growth factors like IGF-1) to observe a strong basal level of phosphorylation that can then be inhibited by **T-448**.

Issue 4: High background on the Western blot membrane.

- Possible Causes & Solutions:
 - Insufficient blocking: Increase the blocking time (e.g., 1-2 hours at room temperature) or try a different blocking agent (e.g., 5% BSA instead of non-fat dry milk).[6][7]
 - Primary antibody concentration too high: Reduce the concentration of the primary antibody.

- Inadequate washing: Increase the number and duration of washing steps after primary and secondary antibody incubations.[6]

Data Presentation

Table 1: IC50 Values of **T-448** in Various Cancer Cell Lines

Cell Line	Cancer Type	Key Mutations	T-448 IC50 (nM)
MCF-7	Breast Cancer	PIK3CA E545K	50
U87-MG	Glioblastoma	PTEN null	75
A549	Lung Cancer	KRAS G12S	>1000
PC-3	Prostate Cancer	PTEN null	120

Table 2: Effect of **T-448** on PI3K/Akt/mTOR Pathway Phosphorylation

Treatment (100 nM T-448)	p-Akt (Ser473) (% of Control)	p-S6 (Ser235/236) (% of Control)
1 hour	25%	30%
4 hours	15%	20%
24 hours	10%	15%

Experimental Protocols

Protocol 1: Cell Viability (MTS Assay)

- Cell Seeding: Seed cells in a 96-well plate at a density of 5,000-10,000 cells per well and allow them to adhere overnight.
- Compound Treatment: Prepare serial dilutions of **T-448** in culture medium and add them to the respective wells. Include a vehicle control (e.g., 0.1% DMSO).
- Incubation: Incubate the plate for 48-72 hours at 37°C in a humidified incubator.

- MTS Reagent Addition: Add 20 μ L of MTS reagent to each well and incubate for 1-4 hours at 37°C.
- Data Acquisition: Measure the absorbance at 490 nm using a microplate reader.
- Data Analysis: Calculate cell viability as a percentage of the vehicle-treated control and determine the IC50 value using non-linear regression analysis.

Protocol 2: Western Blotting for Pathway Analysis

- Cell Lysis: Treat cells with **T-448** for the desired time points. Wash cells with ice-cold PBS and lyse them in RIPA buffer containing protease and phosphatase inhibitors.
- Protein Quantification: Determine the protein concentration of each lysate using a BCA assay.
- SDS-PAGE: Denature 20-30 μ g of protein from each sample by boiling in Laemmli buffer and separate the proteins on a 10% SDS-polyacrylamide gel.
- Protein Transfer: Transfer the separated proteins to a PVDF membrane.
- Blocking: Block the membrane with 5% non-fat dry milk or 5% BSA in Tris-buffered saline with 0.1% Tween 20 (TBST) for 1 hour at room temperature.
- Antibody Incubation: Incubate the membrane with primary antibodies against p-Akt (Ser473), total Akt, p-S6 (Ser235/236), total S6, and a loading control (e.g., β -actin) overnight at 4°C.
- Washing: Wash the membrane three times with TBST for 10 minutes each.
- Secondary Antibody Incubation: Incubate the membrane with an appropriate HRP-conjugated secondary antibody for 1 hour at room temperature.
- Detection: Wash the membrane as in step 7 and detect the signal using an enhanced chemiluminescence (ECL) substrate and an imaging system.

Visualizations

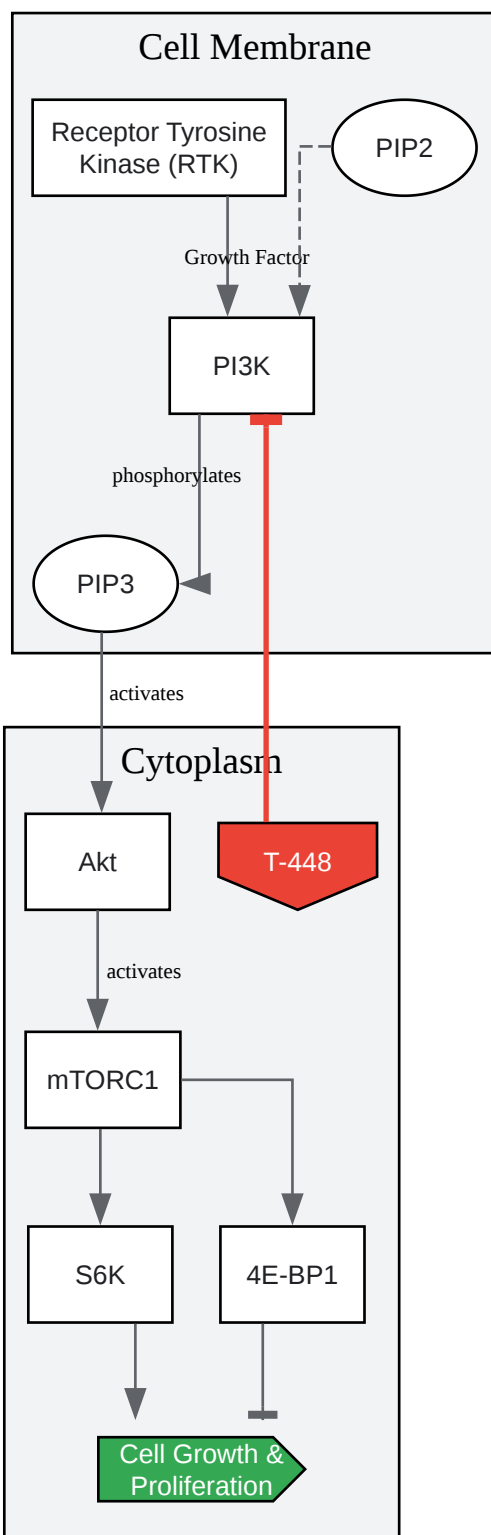

[Click to download full resolution via product page](#)

Caption: **T-448** inhibits the PI3K/Akt/mTOR signaling pathway.

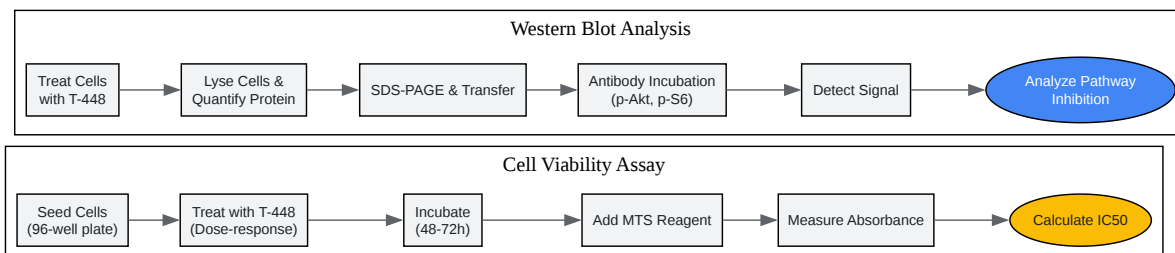

[Click to download full resolution via product page](#)

Caption: Workflow for **T-448** efficacy and mechanism of action studies.

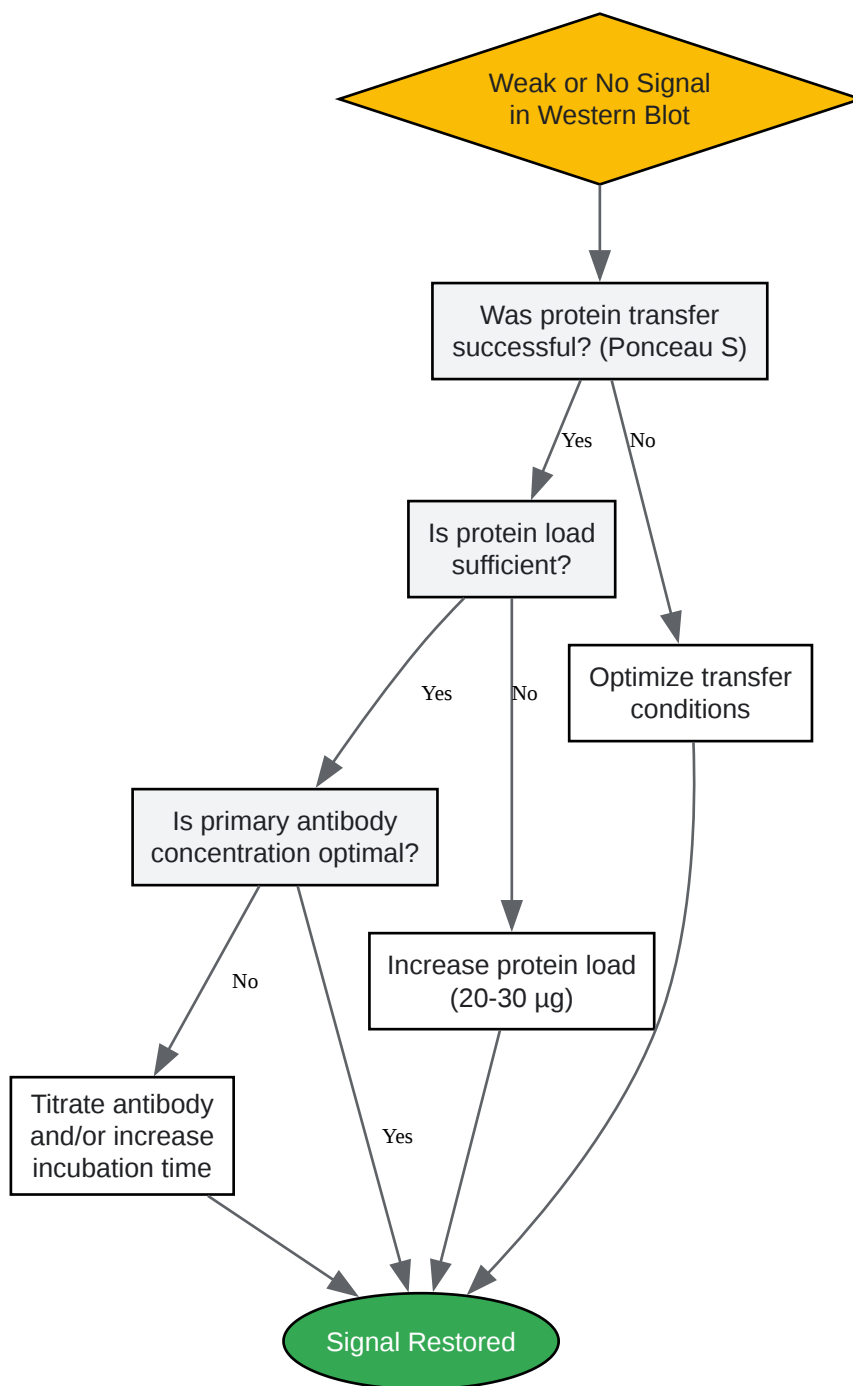

[Click to download full resolution via product page](#)

Caption: Troubleshooting logic for weak Western blot signals.

Need Custom Synthesis?

BenchChem offers custom synthesis for rare earth carbides and specific isotopic labeling.

Email: info@benchchem.com or [Request Quote Online](#).

References

- 1. PI3K/AKT/mTOR Axis in Cancer: From Pathogenesis to Treatment - PMC [[pmc.ncbi.nlm.nih.gov](https://pubmed.ncbi.nlm.nih.gov/)]
- 2. Frontiers | PI3K/Akt/mTOR Pathway and Its Role in Cancer Therapeutics: Are We Making Headway? [[frontiersin.org](https://www.frontiersin.org/)]
- 3. aacrjournals.org [aacrjournals.org]
- 4. PI3K/AKT/mTOR pathway - Wikipedia [en.wikipedia.org]
- 5. [benchchem.com](https://www.benchchem.com) [[benchchem.com](https://www.benchchem.com)]
- 6. Western Blot Troubleshooting Guide - TotalLab [[totallab.com](https://www.total-lab.com/)]
- 7. Western Blot Troubleshooting | Thermo Fisher Scientific - US [[thermofisher.com](https://www.thermofisher.com/)]
- To cite this document: BenchChem. [T-448 Experimental Results: Technical Support Center]. BenchChem, [2026]. [Online PDF]. Available at: [<https://www.benchchem.com/product/b10818703/docs#t-448-experimental-results-technical-support-center>]

Disclaimer & Data Validity:

The information provided in this document is for Research Use Only (RUO) and is strictly not intended for diagnostic or therapeutic procedures. While BenchChem strives to provide accurate protocols, we make no warranties, express or implied, regarding the fitness of this product for every specific experimental setup.

Technical Support: The protocols provided are for reference purposes. Unsure if this reagent suits your experiment?

Need Industrial/Bulk Grade? [Request Custom Synthesis Quote](#)

BenchChem

Our mission is to be the trusted global source of essential and advanced chemicals, empowering scientists and researchers to drive progress in science and industry.

Contact

Address: 3281 E Guasti Rd

Ontario, CA 91761, United States

Phone: (601) 213-4426

Email: info@benchchem.com

[Contact our Ph.D. Support Team for a compatibility check](#)