

Analyzing Cell Cycle Arrest Induced by Eupalinolide K Using Flow Cytometry

Author: BenchChem Technical Support Team. **Date:** April 2026

Compound of Interest

Compound Name: *Eupalinolide K*

Cat. No.: *B10818204*

[Get Quote](#)

Application Note and Protocol

For Researchers, Scientists, and Drug Development Professionals

Introduction

Eupalinolides, a class of sesquiterpene lactones isolated from plants of the Eupatorium genus, have garnered significant interest in oncology research for their potent anti-cancer properties. While direct studies on **Eupalinolide K** are limited, research on a complex containing **Eupalinolide K** and its close analogs, such as Eupalinolide A, J, and O, has demonstrated their capability to induce cell cycle arrest and apoptosis in various cancer cell lines. This document provides a detailed protocol for assessing cell cycle arrest induced by **Eupalinolide K** using flow cytometry with propidium iodide (PI) staining, drawing upon data from closely related eupalinolides to illustrate the expected outcomes and underlying mechanisms.

A study involving a complex designated F1012-2, which is composed of Eupalinolide I, J, and K, has been shown to induce cell cycle arrest at the G2/M phase in MDA-MB-231 triple-negative breast cancer cells[1]. This suggests that **Eupalinolide K**, as a component of this complex, contributes to this cytostatic effect. Further research on related eupalinolides has elucidated specific cell cycle checkpoints that are targeted. For instance, Eupalinolide J has

been observed to cause G0/G1 phase arrest in human prostate cancer cells[2][3], while Eupalinolide A also induces G1 arrest in hepatocellular carcinoma cells[4]. Conversely, Eupalinolide O has been shown to induce G2/M arrest in human breast cancer cells. The varied effects of these structurally similar compounds highlight the importance of detailed cell cycle analysis for each specific agent.

This application note will guide researchers through the process of treating cancer cells with **Eupalinolide K**, preparing the cells for flow cytometry, and analyzing the resulting cell cycle distribution.

Quantitative Data Summary

The following tables summarize the effects of different eupalinolides on the cell cycle distribution in various cancer cell lines. This data is presented to provide a comparative context for designing and interpreting experiments with **Eupalinolide K**.

Table 1: Effect of Eupalinolide J on Cell Cycle Distribution in Prostate Cancer Cells[2][3]

Cell Line	Treatment (24h)	% of Cells in G0/G1	% of Cells in S	% of Cells in G2/M
PC-3	Control	38.74 ± 2.34	-	-
20 µM Eupalinolide J		53.34 ± 4.12	-	-
DU-145	Control	31.59 ± 2.47	-	-
20 µM Eupalinolide J		48.50 ± 3.67	-	-

Table 2: Effect of Eupalinolide A on Cell Cycle Distribution in Hepatocellular Carcinoma Cells[4]

Cell Line	Treatment (48h)	% of Cells in G1	% of Cells in S	% of Cells in G2/M
MHCC97-L	Control	-	-	-
14 μ M Eupalinolide A	Increased	-	-	-
28 μ M Eupalinolide A	Increased	-	-	-
HCCLM3	Control	-	-	-
14 μ M Eupalinolide A	Increased	-	-	-
28 μ M Eupalinolide A	Increased	-	-	-

 Table 3: Effect of F1012-2 (containing **Eupalinolide K**) on Cell Cycle[1]

Cell Line	Treatment	Effect
MDA-MB-231	F1012-2 (Eupalinolide I, J, K)	G2/M Arrest

Signaling Pathways

Eupalinolides exert their effects on the cell cycle through the modulation of various signaling pathways. The diagrams below illustrate the proposed mechanisms for different eupalinolides.

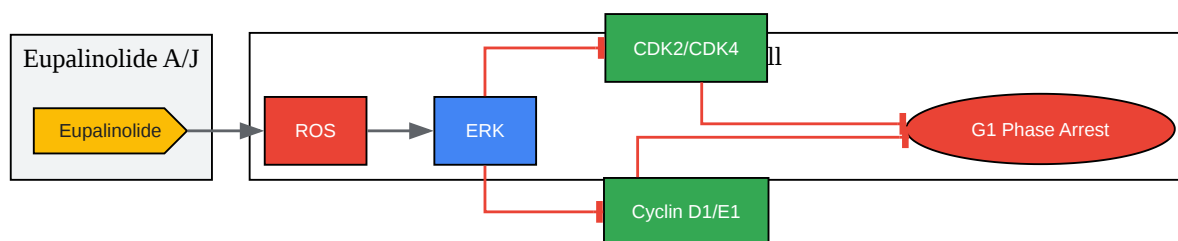

[Click to download full resolution via product page](#)

Caption: Proposed signaling pathway for Eupalinolide A/J-induced G1 cell cycle arrest.

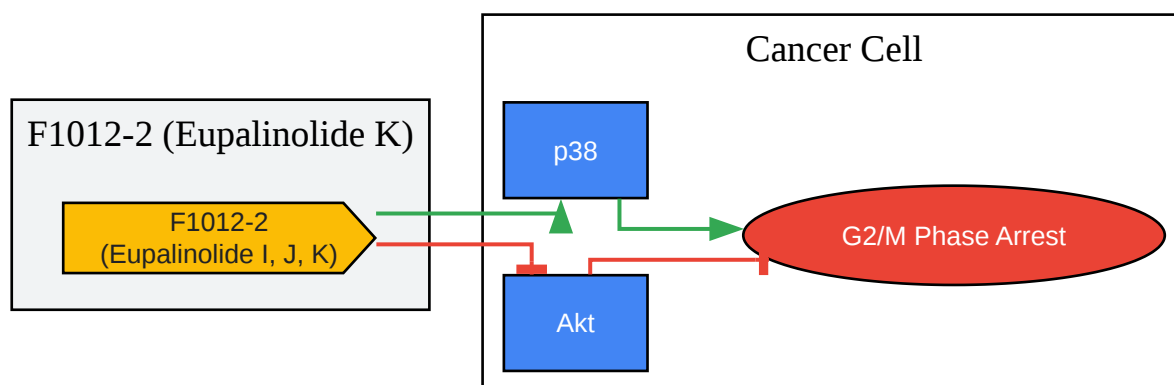

[Click to download full resolution via product page](#)

Caption: Signaling pathway for F1012-2 (containing **Eupalinolide K**)-induced G2/M arrest.

Experimental Protocol: Cell Cycle Analysis by Flow Cytometry

This protocol details the steps for analyzing cell cycle distribution in cancer cells treated with **Eupalinolide K** using propidium iodide (PI) staining.

Materials

- **Eupalinolide K** (dissolved in DMSO to create a stock solution)
- Cancer cell line of interest (e.g., MDA-MB-231, PC-3, A549)
- Complete cell culture medium (e.g., DMEM or RPMI-1640 with 10% FBS)
- Phosphate-Buffered Saline (PBS), ice-cold
- 70% Ethanol, ice-cold
- Propidium Iodide (PI) staining solution (e.g., 50 µg/mL PI and 100 µg/mL RNase A in PBS)
- Flow cytometer

- 15 mL conical tubes
- Microcentrifuge tubes
- Cell scraper (for adherent cells)

Experimental Workflow

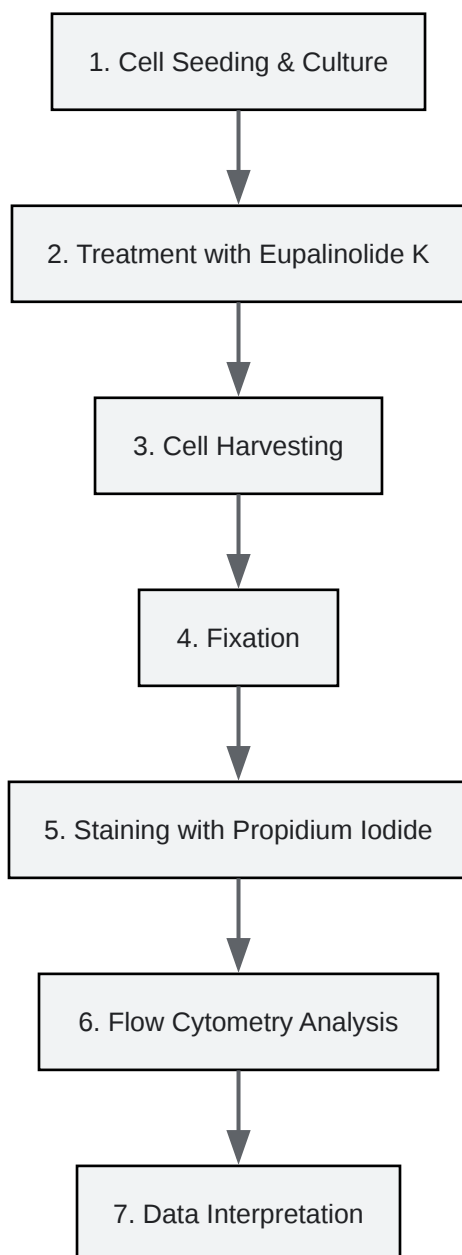

[Click to download full resolution via product page](#)

Need Custom Synthesis?

BenchChem offers custom synthesis for rare earth carbides and specific isotopic labeling.

Email: info@benchchem.com or [Request Quote Online](#).

References

- 1. Eupalinolide J Inhibits Cancer Metastasis by Promoting STAT3 Ubiquitin-Dependent Degradation - PMC [[pmc.ncbi.nlm.nih.gov](https://pubmed.ncbi.nlm.nih.gov)]
- 2. Eupalinolide J induces apoptosis, cell cycle arrest, mitochondrial membrane potential disruption and DNA damage in human prostate cancer cells [jstage.jst.go.jp]
- 3. Eupalinolide J induces apoptosis, cell cycle arrest, mitochondrial membrane potential disruption and DNA damage in human prostate cancer cells - PubMed [pubmed.ncbi.nlm.nih.gov]
- 4. Eupalinolide A induces autophagy via the ROS/ERK signaling pathway in hepatocellular carcinoma cells in vitro and in vivo - PMC [[pmc.ncbi.nlm.nih.gov](https://pubmed.ncbi.nlm.nih.gov)]
- To cite this document: BenchChem. [Analyzing Cell Cycle Arrest Induced by Eupalinolide K Using Flow Cytometry]. BenchChem, [2026]. [Online PDF]. Available at: [<https://www.benchchem.com/product/b10818204/docs#analyzing-cell-cycle-arrest-induced-by-eupalinolide-k-using-flow-cytometry>]

Disclaimer & Data Validity:

The information provided in this document is for Research Use Only (RUO) and is strictly not intended for diagnostic or therapeutic procedures. While BenchChem strives to provide accurate protocols, we make no warranties, express or implied, regarding the fitness of this product for every specific experimental setup.

Technical Support: The protocols provided are for reference purposes. Unsure if this reagent suits your experiment?

Need Industrial/Bulk Grade? [Request Custom Synthesis Quote](#)

BenchChem

Our mission is to be the trusted global source of essential and advanced chemicals, empowering scientists and researchers to drive progress in science and industry.

Contact

Address: 3281 E Guasti Rd

Ontario, CA 91761, United States

Phone: (601) 213-4426

Email: info@benchchem.com

[Contact our Ph.D. Support Team for a compatibility check](#)