

Technical Support Center: LASSBio-1135 In Vivo Studies

Author: BenchChem Technical Support Team. **Date:** April 2026

Compound of Interest

Compound Name: LASSBio-1135

Cat. No.: B10816846

[Get Quote](#)

This technical support center provides troubleshooting guidance and frequently asked questions (FAQs) to assist researchers, scientists, and drug development professionals in minimizing variability in in vivo studies involving **LASSBio-1135**.

Troubleshooting Guides & FAQs

This section addresses specific issues that may be encountered during in vivo experiments with **LASSBio-1135**, presented in a question-and-answer format.

1. Compound Formulation and Administration

- Question: My **LASSBio-1135** formulation appears inconsistent between preparations, potentially affecting oral bioavailability. How can I improve consistency?
 - Answer: **LASSBio-1135** has limited aqueous solubility. For oral administration, a suspension in 5% arabic gum in saline has been used effectively.[1] Alternatively, a clear solution can be prepared using a vehicle of 10% DMSO, 40% PEG300, 5% Tween-80, and 45% saline.[2][3] To ensure consistency:
 - Always use the same high-purity reagents and vehicle components.

- Prepare the formulation fresh on the day of the experiment.[2]
 - If using a suspension, ensure it is homogenous by vortexing immediately before each administration.
 - For solutions, ensure the compound is fully dissolved. Gentle heating and/or sonication can aid dissolution.[2]
 - The chosen vehicle should be consistent across all treatment groups, including the control group.[4][5]
- Question: I am observing high variability in the therapeutic effect of **LASSBio-1135** after oral gavage. What could be the cause?
 - Answer: Variability after oral administration can stem from several factors:
 - Inconsistent Dosing Volume: Ensure accurate dosing volumes based on the most recent body weight of each animal.
 - Improper Gavage Technique: Improper technique can cause stress or injury, affecting physiological responses. Ensure all personnel are thoroughly trained and consistent in their technique.
 - Pharmacokinetic Variability: Factors such as food in the stomach can affect drug absorption. Standardize the fasting period for all animals before dosing. While specific pharmacokinetic data for **LASSBio-1135** is not readily available, inconsistent absorption is a common source of variability for orally administered compounds.

2. Animal and Environmental Factors

- Question: The baseline pain thresholds of my animals are highly variable. How can I reduce this?
 - Answer: Baseline variability can obscure the true effect of **LASSBio-1135**. To minimize this:
 - Acclimatization: Allow sufficient time for animals to acclimate to the housing facility and testing environment.

- Handling: Handle animals consistently and gently to reduce stress, as stress can alter pain perception.
 - Standardized Procedures: Ensure that the same person, using the same technique, performs the baseline measurements at the same time of day for all animals.
 - Exclusion Criteria: Establish clear exclusion criteria for animals that show extreme baseline responses.
- Question: I am seeing significant differences in inflammatory responses between cages of animals in the same treatment group. What could be the issue?
 - Answer: Inter-cage variability can be due to micro-environmental differences.
 - Cage Conditions: Ensure consistent bedding, temperature, humidity, and light cycles across all cages.
 - Randomization: Properly randomize animals to treatment groups and cage locations to avoid systematic bias.
 - Health Status: Use specific-pathogen-free (SPF) animals and monitor their health status, as subclinical infections can affect inflammatory responses.

3. Experimental Procedure

- Question: The results of my carrageenan-induced paw edema assay are not consistent. What should I check?
 - Answer: Key factors affecting this assay's reproducibility include:
 - Carrageenan Injection: The volume and injection site of the carrageenan must be precise and consistent. Intra- and inter-operator variability in injection technique is a major source of error.
 - Paw Volume Measurement: Use a calibrated plethysmometer and ensure the paw is immersed to the same anatomical mark each time.

- Timing: The timing of **LASSBio-1135** administration relative to the carrageenan injection, and the time points for paw volume measurement, should be strictly adhered to.[6]
- Question: My data from the von Frey test for mechanical allodynia is highly variable. How can I improve it?
 - Answer: The von Frey test is operator-dependent and requires careful execution:
 - Consistent Application: Apply the filaments to the same area of the paw with a consistent application force and duration.
 - Blinding: The operator should be blinded to the treatment groups to prevent unconscious bias.
 - Habituation: Ensure animals are properly habituated to the testing apparatus to minimize stress-related responses.

Quantitative Data Summary

The following tables summarize the reported in vitro and in vivo efficacy of **LASSBio-1135**.

Parameter	Value	Cell/System	Condition	Reference
TRPV1 Antagonism	IC ₅₀ = 580 nM	TRPV1-expressing Xenopus oocytes	Capsaicin-elicited currents	[7]
TNF-α Inhibition	IC ₅₀ = 546 nM	LPS-stimulated murine peritoneal macrophages	TNF-α release	[7]
COX-2 Inhibition	IC ₅₀ = 18.5 μM	Human PGHS-2 enzyme	Enzyme activity	[3]

Table 1: In Vitro Activity of **LASSBio-1135**.

Animal Model	LASSBio-1135 Dose (oral)	Key Findings	Reference
Carrageenan-Induced Thermal Hyperalgesia	10 µmol/kg	Partial reduction in thermal hyperalgesia at 4 hours.	[7]
100 µmol/kg	Marked reduction in thermal hyperalgesia.	[7]	
Partial Sciatic Ligation (Neuropathic Pain)	100 µmol/kg	Reversal of thermal hyperalgesia and mechanical allodynia.	[7]

Table 2: In Vivo Efficacy of **LASSBio-1135**.

Experimental Protocols

1. Carrageenan-Induced Thermal Hyperalgesia

- Animals: Male Swiss mice or Wistar rats.
- Compound Administration: Administer **LASSBio-1135** (10 or 100 µmol/kg) or vehicle orally (e.g., as a suspension in 5% arabic gum in saline).[1]
- Induction of Inflammation: One hour after compound administration, inject 0.1 ml of 1% carrageenan solution in sterile saline into the subplantar surface of the right hind paw.[1]
- Assessment of Thermal Hyperalgesia: At various time points (e.g., 1, 2, 3, and 4 hours) after carrageenan injection, measure the paw withdrawal latency to a thermal stimulus (e.g., using a radiant heat source). An increase in paw withdrawal latency indicates an anti-hyperalgesic effect.

2. Partial Sciatic Ligation-Induced Neuropathic Pain

- Animals: Male Wistar rats.

- **Surgical Procedure:** Anesthetize the animals and expose the sciatic nerve. Ligate approximately one-third to one-half of the diameter of the nerve with a suture.
- **Compound Administration:** Administer **LASSBio-1135** (e.g., 100 $\mu\text{mol/kg}$, orally) or vehicle daily, starting several days post-surgery.
- **Assessment of Mechanical Allodynia:** Measure the paw withdrawal threshold to mechanical stimulation using von Frey filaments at various time points post-ligation. An increase in the withdrawal threshold indicates an anti-allodynic effect.
- **Assessment of Thermal Hyperalgesia:** Measure the paw withdrawal latency to a thermal stimulus as described above. An increase in withdrawal latency indicates an anti-hyperalgesic effect.

Visualizations

Signaling Pathway of **LASSBio-1135**

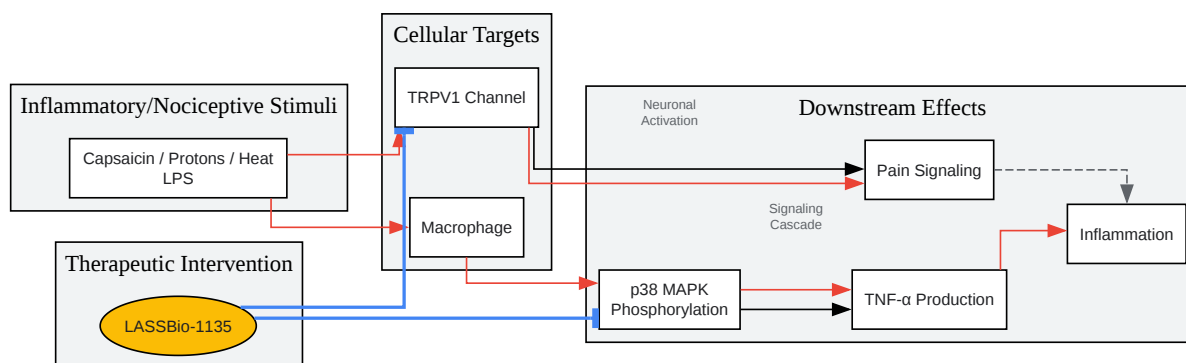

[Click to download full resolution via product page](#)

Caption: Dual inhibitory mechanism of **LASSBio-1135** on TRPV1 and TNF- α pathways.

Experimental Workflow for **LASSBio-1135** In Vivo Study

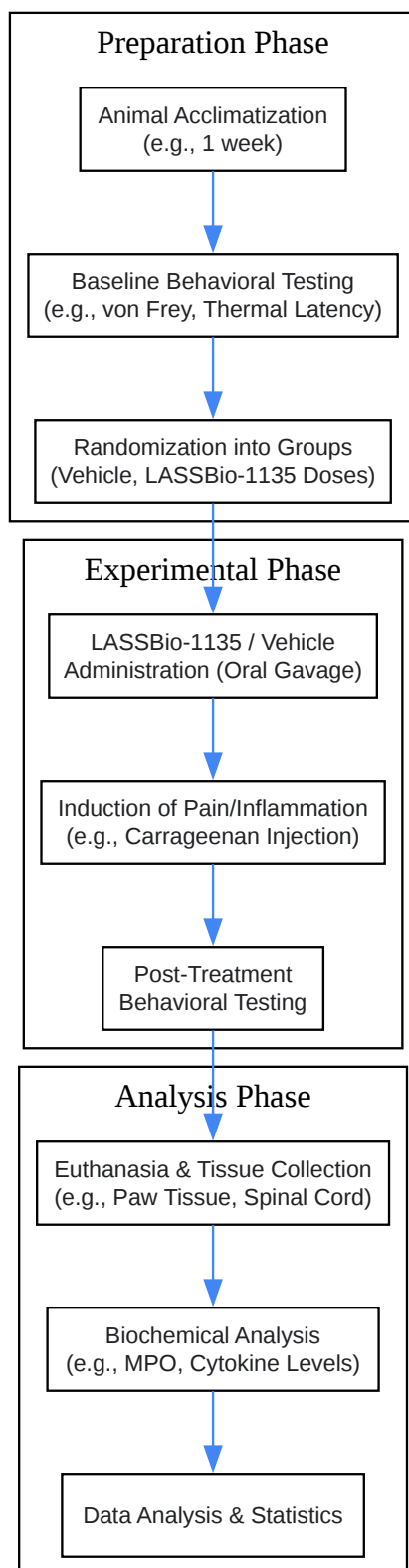

[Click to download full resolution via product page](#)

Caption: General workflow for an in vivo pain and inflammation study with **LASSBio-1135**.

Troubleshooting Logic for High Variability

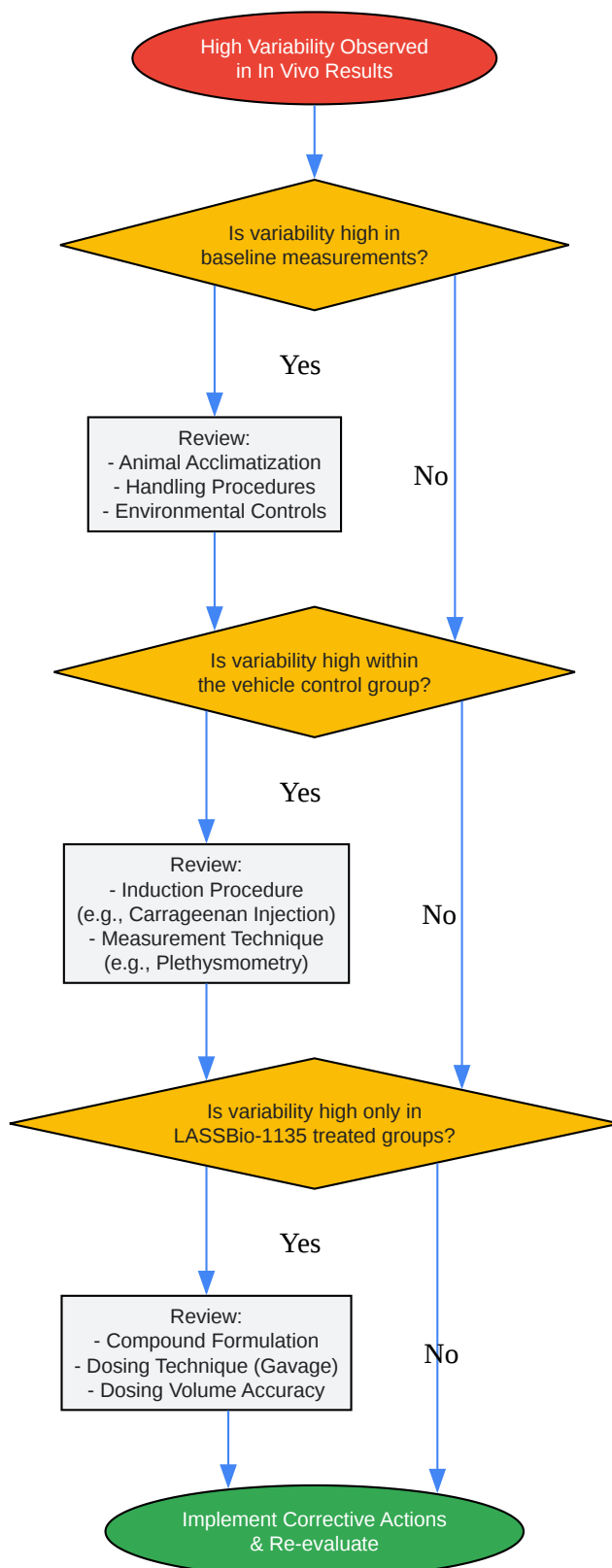

[Click to download full resolution via product page](#)

Caption: Decision tree for troubleshooting sources of variability in **LASSBio-1135** studies.

Need Custom Synthesis?

BenchChem offers custom synthesis for rare earth carbides and specific isotopic labeling.

Email: info@benchchem.com or [Request Quote Online](#).

References

- 1. LASSBio-1135: A Dual TRPV1 Antagonist and Anti-TNF-Alpha Compound Orally Effective in Models of Inflammatory and Neuropathic Pain - PMC [[pmc.ncbi.nlm.nih.gov](https://pubmed.ncbi.nlm.nih.gov/)]
- 2. [medchemexpress.com](https://www.medchemexpress.com/) [[medchemexpress.com](https://www.medchemexpress.com/)]
- 3. [medchemexpress.com](https://www.medchemexpress.com/) [[medchemexpress.com](https://www.medchemexpress.com/)]
- 4. Influence of Vehicles Used for Oral Dosing of Test Molecules on the Progression of Mycobacterium tuberculosis Infection in Mice - PMC [[pmc.ncbi.nlm.nih.gov](https://pubmed.ncbi.nlm.nih.gov/)]
- 5. journals.asm.org [journals.asm.org]
- 6. [inotiv.com](https://www.inotiv.com/) [[inotiv.com](https://www.inotiv.com/)]
- 7. LASSBio-1135: a dual TRPV1 antagonist and anti-TNF-alpha compound orally effective in models of inflammatory and neuropathic pain - PubMed [pubmed.ncbi.nlm.nih.gov]
- To cite this document: BenchChem. [Technical Support Center: LASSBio-1135 In Vivo Studies]. BenchChem, [2026]. [Online PDF]. Available at: [<https://www.benchchem.com/product/b10816846/docs#technical-support-center-lassbio-1135-in-vivo-studies>]

Disclaimer & Data Validity:

The information provided in this document is for Research Use Only (RUO) and is strictly not intended for diagnostic or therapeutic procedures. While BenchChem strives to provide accurate protocols, we make no warranties, express or implied, regarding the fitness of this product for every specific experimental setup.

Technical Support: The protocols provided are for reference purposes. Unsure if this reagent suits your experiment?

Need Industrial/Bulk Grade? [Request Custom Synthesis Quote](#)

BenchChem

Our mission is to be the trusted global source of essential and advanced chemicals, empowering scientists and researchers to drive progress in science and industry.

Contact

Address: 3281 E Guasti Rd
Ontario, CA 91761, United States
Phone: (601) 213-4426
Email: info@benchchem.com

[Contact our Ph.D. Support Team for a compatibility check](#)