

Benchmarking new ER proteostasis regulators against existing compounds

Author: BenchChem Technical Support Team. **Date:** April 2026

Compound of Interest

Compound Name: *ER proteostasis regulator-1*

Cat. No.: *B10816727*

[Get Quote](#)

Benchmarking Novel ER Proteostasis Regulators: A Comparative Guide

For Researchers, Scientists, and Drug Development Professionals

The endoplasmic reticulum (ER) is a critical organelle responsible for the proper folding and processing of a significant portion of the cellular proteome. The accumulation of misfolded proteins in the ER, a condition known as ER stress, activates a complex signaling network called the Unfolded Protein Response (UPR). The UPR aims to restore proteostasis by reducing protein synthesis, enhancing protein folding capacity, and promoting the degradation of misfolded proteins. However, chronic or unresolved ER stress can lead to apoptosis. Consequently, the modulation of ER proteostasis has emerged as a promising therapeutic strategy for a wide range of diseases, including neurodegenerative disorders, metabolic diseases, and cancer.

This guide provides a comparative analysis of novel ER proteostasis regulators against established compounds, offering a framework for their evaluation. We present quantitative data from key experimental assays in a structured format, detail the underlying experimental protocols, and visualize the relevant biological pathways and workflows.

Comparative Performance of ER Proteostasis Regulators

The following table summarizes the quantitative performance of selected new and existing ER proteostasis regulators across various assays. This data has been compiled from multiple studies to provide a comparative overview. "Existing Compounds" are well-established inducers of ER stress, often used as positive controls, while "New Compounds" represent more recently developed modulators with potentially more specific mechanisms of action.

Compound	Class/Target	Cell Viability (IC50/EC50)	UPR Branch Activation (EC50/Fold Induction)	Effect on Protein Aggregation	Reference
Existing Compounds					
Thapsigargin (Tg)	SERCA pump inhibitor	~1 μ M (Varies by cell line)	Global UPR activator	Induces protein aggregation	[1][2]
Tunicamycin (Tm)	N-linked glycosylation inhibitor	~2-5 μ g/mL (Varies by cell line)	Global UPR activator	Induces protein aggregation	[1][2]
New Compounds					
ATF6 Activators					
Compound 147	Preferential ATF6 activator	Low cytotoxicity reported	ERSE-FLuc: >2-fold activation over XBP1s-RLuc	Reduces secretion of amyloidogenic proteins	[3][4][5]
Compound 263	Preferential ATF6 activator	Low cytotoxicity reported	ERSE-FLuc: >2-fold activation over XBP1s-RLuc	Reduces secretion of amyloidogenic proteins	[3][4][5]
PERK Inhibitors					
PERK-IN-2	PERK inhibitor	Not reported in these sources	p-PERK IC50: 0.03 - 0.1 μ M	Aims to mitigate chronic PERK	[6]

activation
effects

GSK2606414	PERK inhibitor	Not reported in these sources	PERK IC50: <1 nM (in vitro)	Prevents tau-mediated neurodegeneration in a mouse model	[1] [6] [7]
------------	----------------	-------------------------------	-----------------------------	--	---

Global UPR Modulators

Compound 132	Global UPR activator	Not reported in these sources	Activates ATF6, IRE1, and PERK pathways	Not explicitly stated	[4] [5]
--------------	----------------------	-------------------------------	---	-----------------------	---

Disclaimer: The values presented are approximate and can vary significantly based on the specific cell line, experimental conditions, and assay used. Direct comparison between studies should be made with caution.

Signaling Pathways and Experimental Workflows

To understand the mechanism of action of these compounds, it is crucial to visualize the signaling pathways they modulate and the experimental workflows used for their characterization.

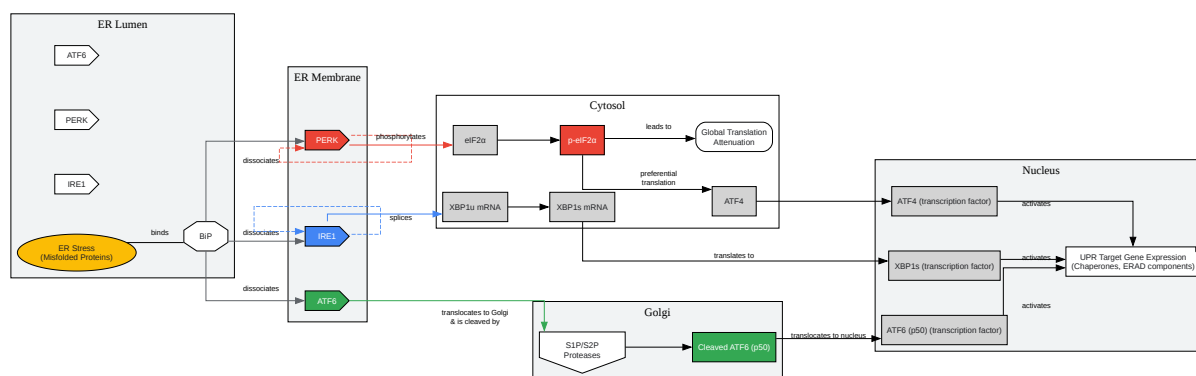

[Click to download full resolution via product page](#)

Caption: The Unfolded Protein Response (UPR) signaling pathway.

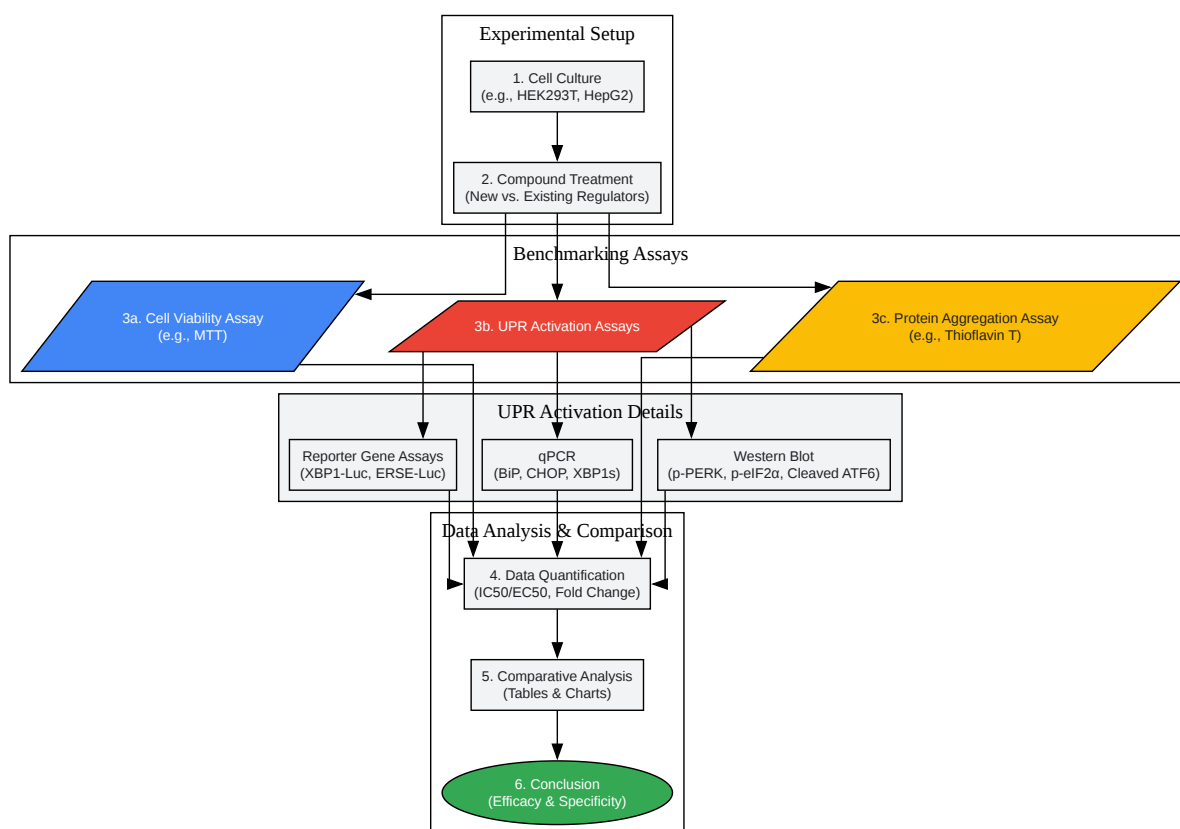

[Click to download full resolution via product page](#)

Caption: A typical experimental workflow for benchmarking ER proteostasis regulators.

Experimental Protocols

Detailed methodologies are essential for the accurate interpretation and replication of experimental results. Below are protocols for key assays used to benchmark ER proteostasis regulators.

Cell Viability Assay (MTT Assay)

This assay assesses the effect of compounds on cell viability by measuring the metabolic activity of living cells.[\[2\]](#)[\[8\]](#)[\[9\]](#)

- Cell Seeding: Plate cells (e.g., H1299, T24, RT4) in a 96-well plate at a density of 5×10^3 to 1×10^5 cells/well and allow them to adhere overnight.[\[2\]](#)[\[8\]](#)
- Compound Treatment: Treat cells with a range of concentrations of the test compounds (e.g., 0, 10, 25, 50, 100 μM) and include appropriate positive (e.g., Thapsigargin) and vehicle controls.[\[2\]](#)
- Incubation: Incubate the cells for a predetermined period (e.g., 24 or 48 hours).[\[2\]](#)
- MTT Addition: Add 20 μL of MTT solution (5 mg/mL in PBS) to each well and incubate for 4 hours at 37°C.[\[2\]](#)
- Solubilization: Carefully remove the medium and add 150 μL of DMSO to each well to dissolve the formazan crystals.[\[2\]](#)
- Measurement: Measure the absorbance at 570 nm using a microplate reader.[\[2\]](#)
- Data Analysis: Calculate cell viability as a percentage of the untreated control and determine the IC50 value by plotting cell viability against the logarithm of the compound concentration.[\[2\]](#)

UPR Reporter Gene Assay

These assays utilize reporter constructs (e.g., luciferase) under the control of UPR-responsive promoters to quantify the activation of specific UPR branches.[\[5\]](#)[\[10\]](#)[\[11\]](#)

- Cell Transfection (if necessary): Transfect cells with the appropriate reporter plasmid (e.g., ERSE-FLuc for ATF6, XBP1-RLuc for IRE1).
- Cell Seeding: Plate the transfected or stable reporter cell line in a 96-well plate.
- Compound Treatment: Treat cells with various concentrations of the test compounds for a specified duration (e.g., 18 hours).[4]
- Lysis and Reagent Addition: Lyse the cells and add the appropriate luciferase assay reagent according to the manufacturer's protocol.[12]
- Measurement: Measure luminescence using a plate reader.
- Data Analysis: Normalize the reporter activity to a control (e.g., vehicle or a constitutively expressed reporter) and express the results as fold activation. For comparative analysis, activation can be normalized to a known global UPR inducer like Thapsigargin.[5]

Quantitative PCR (qPCR) for UPR Target Genes

qPCR measures the mRNA levels of key UPR target genes to assess the activation of the different signaling branches.[13][14]

- Cell Treatment and RNA Extraction: Treat cells with the compounds for the desired time, then harvest the cells and extract total RNA using a suitable kit.
- cDNA Synthesis: Synthesize cDNA from the extracted RNA using a reverse transcription kit.
- qPCR: Perform qPCR using primers specific for UPR target genes (e.g., HSPA5 (BiP) for ATF6, spliced XBP1 for IRE1, and DDIT3 (CHOP) for PERK) and a housekeeping gene for normalization (e.g., GAPDH).
- Data Analysis: Calculate the relative gene expression using the $\Delta\Delta C_t$ method, expressed as fold change compared to the vehicle-treated control.

Western Blotting for UPR Markers

Western blotting is used to detect the protein levels and post-translational modifications of key UPR signaling molecules.[6][13]

- Cell Lysis: Treat cells with the compounds, then lyse the cells in RIPA buffer containing protease and phosphatase inhibitors.[6]
- Protein Quantification: Determine the protein concentration of the lysates using a BCA assay. [6]
- SDS-PAGE and Transfer: Separate equal amounts of protein on an SDS-PAGE gel and transfer them to a PVDF or nitrocellulose membrane.[6]
- Immunoblotting: Block the membrane and then incubate with primary antibodies against specific UPR markers (e.g., phospho-PERK, phospho-eIF2 α , total PERK, total eIF2 α , cleaved ATF6, or β -actin as a loading control).[6][15]
- Detection: Incubate with HRP-conjugated secondary antibodies and visualize the bands using a chemiluminescence imaging system.[6]
- Data Analysis: Quantify the band intensities and normalize to the loading control to determine the relative protein levels or phosphorylation status.

Protein Aggregation Assay (Thioflavin T Assay)

This assay is used to quantify the formation of protein aggregates, a hallmark of severe ER stress.[16][17]

- Cell Treatment: Treat cells with the compounds to induce ER stress and potential protein aggregation.
- Cell Lysis and Fractionation: Lyse the cells and separate the soluble and insoluble protein fractions by centrifugation.[17]
- Thioflavin T Staining: Incubate the insoluble fraction with Thioflavin T (ThT), a dye that exhibits enhanced fluorescence upon binding to amyloid-like aggregates.[16]
- Measurement: Measure the fluorescence intensity using a fluorometer.
- Data Analysis: Compare the fluorescence intensity of treated samples to that of control samples to determine the relative level of protein aggregation.

By employing these standardized protocols and comparing the results in a structured manner, researchers can effectively benchmark new ER proteostasis regulators against existing compounds, facilitating the identification and development of novel therapeutics for a variety of diseases.

Need Custom Synthesis?

BenchChem offers custom synthesis for rare earth carbides and specific isotopic labeling.

Email: info@benchchem.com or [Request Quote Online](#).

References

- [1. Frontiers | A Pipeline for Natural Small Molecule Inhibitors of Endoplasmic Reticulum Stress \[frontiersin.org\]](#)
- [2. benchchem.com \[benchchem.com\]](#)
- [3. Small molecule proteostasis regulators that reprogram the ER to reduce extracellular protein aggregation - PubMed \[pubmed.ncbi.nlm.nih.gov\]](#)
- [4. Small molecule proteostasis regulators that reprogram the ER to reduce extracellular protein aggregation - PMC \[pmc.ncbi.nlm.nih.gov\]](#)
- [5. Small molecule proteostasis regulators that reprogram the ER to reduce extracellular protein aggregation | eLife \[elifesciences.org\]](#)
- [6. benchchem.com \[benchchem.com\]](#)
- [7. benchchem.com \[benchchem.com\]](#)
- [8. 4.3. Cell Viability Assay \[bio-protocol.org\]](#)
- [9. WST-1 Assay: principles, protocol & best practices for cell viability | Abcam \[abcam.com\]](#)
- [10. Drosophila Unfolded Protein Response \(UPR\) assays in vitro and in vivo - PMC \[pmc.ncbi.nlm.nih.gov\]](#)
- [11. researchgate.net \[researchgate.net\]](#)
- [12. journals.plos.org \[journals.plos.org\]](#)
- [13. Methods for Studying ER Stress and UPR Markers in Human Cells | Springer Nature Experiments \[experiments.springernature.com\]](#)

- [14. Comparative analysis of the expression patterns of UPR-target genes caused by UPR-inducing compounds - PubMed \[pubmed.ncbi.nlm.nih.gov\]](#)
- [15. documents.thermofisher.com \[documents.thermofisher.com\]](#)
- [16. How do I detect ER stress? | AAT Bioquest \[aatbio.com\]](#)
- [17. spandidos-publications.com \[spandidos-publications.com\]](#)
- To cite this document: BenchChem. [Benchmarking new ER proteostasis regulators against existing compounds]. BenchChem, [2026]. [Online PDF]. Available at: [\[https://www.benchchem.com/product/b10816727/docs#benchmarking-new-er-proteostasis-regulators-against-existing-compounds\]](https://www.benchchem.com/product/b10816727/docs#benchmarking-new-er-proteostasis-regulators-against-existing-compounds)

Disclaimer & Data Validity:

The information provided in this document is for Research Use Only (RUO) and is strictly not intended for diagnostic or therapeutic procedures. While BenchChem strives to provide accurate protocols, we make no warranties, express or implied, regarding the fitness of this product for every specific experimental setup.

Technical Support: The protocols provided are for reference purposes. Unsure if this reagent suits your experiment?

Need Industrial/Bulk Grade? [Request Custom Synthesis Quote](#)

BenchChem

Our mission is to be the trusted global source of essential and advanced chemicals, empowering scientists and researchers to drive progress in science and industry.

Contact

Address: 3281 E Guasti Rd
Ontario, CA 91761, United States
Phone: (601) 213-4426
Email: info@benchchem.com

Contact our Ph.D. Support Team for a compatibility check