

Troubleshooting Urease-IN-14 insolubility issues

Author: BenchChem Technical Support Team. **Date:** April 2026

Compound of Interest

Compound Name: Urease-IN-14

Cat. No.: B10815107

[Get Quote](#)

Technical Support Center: Urease-IN-14

This technical support center provides troubleshooting guides and frequently asked questions (FAQs) to assist researchers, scientists, and drug development professionals in overcoming challenges with **Urease-IN-14**, particularly concerning its solubility.

Frequently Asked Questions (FAQs)

Q1: What is **Urease-IN-14**?

A1: **Urease-IN-14** is a chemical compound identified as a urease inhibitor and an antioxidant. It has been shown to exhibit inhibitory activity against the enzyme urease and also possesses DPPH radical scavenging properties.^[1]

Q2: What is the primary application of **Urease-IN-14** in research?

A2: **Urease-IN-14** is primarily used in research to study the function and inhibition of the enzyme urease. Urease is a key enzyme in the nitrogen cycle and a virulence factor for several pathogenic bacteria, such as *Helicobacter pylori*. Therefore, inhibitors like **Urease-IN-14** are valuable tools for drug development and agricultural research.

Q3: In what solvents is **Urease-IN-14** soluble?

A3: While specific solubility data for **Urease-IN-14** is not readily available, it is common for small molecule inhibitors of this nature to have limited solubility in aqueous solutions. For experimental purposes, it is recommended to first dissolve **Urease-IN-14** in an organic solvent such as dimethyl sulfoxide (DMSO) to prepare a concentrated stock solution. This stock solution can then be diluted into the aqueous buffer of your experiment to the desired final concentration.

Q4: What is the mechanism of action of urease?

A4: Urease catalyzes the hydrolysis of urea into ammonia and carbon dioxide. This reaction leads to an increase in the pH of the surrounding environment due to the production of ammonia, which is basic. The active site of urease contains nickel ions that are crucial for its catalytic activity.

Troubleshooting Guide: Urease-IN-14 Insolubility

Researchers may encounter difficulties in dissolving **Urease-IN-14** for their experiments. The following guide provides a systematic approach to address these solubility issues.

Issue 1: Urease-IN-14 precipitate is observed in the aqueous buffer.

This is the most common issue and typically arises from the low aqueous solubility of the compound.

Troubleshooting Steps:

- Prepare a Concentrated Stock Solution in an Organic Solvent:
 - Instead of dissolving **Urease-IN-14** directly in your aqueous buffer, first prepare a high-concentration stock solution in 100% DMSO.
 - Ensure the DMSO is of high purity and anhydrous to prevent any potential degradation of the compound.
- Optimize the Final Concentration of Organic Solvent:

- When diluting the DMSO stock solution into your aqueous buffer, ensure the final concentration of DMSO is kept to a minimum (typically $\leq 1\%$ v/v) to avoid affecting the biological system or enzyme activity.
- Perform a vehicle control experiment with the same final concentration of DMSO to assess its effect on your assay.
- Sonication:
 - After preparing the stock solution in DMSO, brief sonication can help to break up any small aggregates and ensure complete dissolution.
 - Similarly, after diluting the stock solution into the aqueous buffer, gentle vortexing or brief sonication of the final solution can aid in keeping the compound dissolved.
- Heating:
 - Gentle warming of the stock solution in DMSO (e.g., to 37°C) may increase the solubility. However, be cautious as excessive heat can degrade the compound. Always refer to the manufacturer's stability data if available.

Issue 2: Inconsistent results or lower than expected inhibitory activity.

This could be a consequence of incomplete dissolution or precipitation of **Urease-IN-14** during the experiment.

Troubleshooting Steps:

- Visual Inspection:
 - Before starting your assay, visually inspect your final solution containing **Urease-IN-14** for any signs of precipitation or cloudiness. Use a light source against a dark background for better visibility.
- Centrifugation:

- If you suspect precipitation, centrifuge your final solution at high speed (e.g., >10,000 x g) for 10-15 minutes. A visible pellet will confirm precipitation.
- Test Different Stock Concentrations:
 - Prepare a serial dilution of your **Urease-IN-14** stock solution in DMSO before diluting it into the aqueous buffer. This can help determine the optimal concentration range where the compound remains soluble.

Quantitative Data Summary

For a typical urease inhibition assay, the following concentrations are relevant. Note that the solubility of **Urease-IN-14** will dictate the achievable concentrations in the final assay.

Parameter	Recommended Concentration/Value	Notes
Urease-IN-14 Stock Solution	10-50 mM in 100% DMSO	Prepare fresh and store at -20°C or -80°C.
Final DMSO Concentration in Assay	≤ 1% (v/v)	Minimize to avoid off-target effects.
Urease Enzyme Concentration	Varies by source and activity	Refer to supplier's datasheet.
Urea Substrate Concentration	Varies by assay	Should be around the Km of the enzyme.
pH of Assay Buffer	7.0 - 8.0	Optimal pH for urease activity.

Experimental Protocols

Protocol 1: Preparation of Urease-IN-14 Stock Solution

- Weighing: Accurately weigh a small amount of **Urease-IN-14** powder using a calibrated analytical balance.
- Dissolution: Add the appropriate volume of 100% DMSO to achieve the desired stock solution concentration (e.g., 10 mM).

- Mixing: Vortex the solution for 1-2 minutes to facilitate dissolution.
- Sonication (Optional): If the compound does not fully dissolve, sonicate the vial in a water bath for 5-10 minutes.
- Storage: Store the stock solution in small aliquots at -20°C or -80°C to avoid repeated freeze-thaw cycles.

Protocol 2: Urease Inhibition Assay (Colorimetric)

This protocol is a general guideline and may need to be optimized for your specific experimental conditions.

- Reagent Preparation:
 - Assay Buffer: Prepare a suitable buffer (e.g., 100 mM phosphate buffer, pH 7.4).
 - Urease Solution: Prepare a working solution of urease enzyme in the assay buffer. The final concentration will depend on the specific activity of the enzyme.
 - Urea Solution: Prepare a stock solution of urea in the assay buffer.
 - Detection Reagent: Prepare the reagents for ammonia detection (e.g., Berthelot's reagent).
- Assay Procedure:
 - Add 50 μ L of assay buffer to the wells of a 96-well plate.
 - Add 10 μ L of **Urease-IN-14** working solution (prepared by diluting the DMSO stock in assay buffer) or vehicle control (assay buffer with the same final concentration of DMSO).
 - Add 20 μ L of the urease enzyme solution to each well and incubate for 10-15 minutes at 37°C.
 - Initiate the reaction by adding 20 μ L of the urea solution to each well.
 - Incubate the plate at 37°C for a predetermined time (e.g., 30 minutes).

- Stop the reaction and develop the color by adding the detection reagent according to the manufacturer's instructions.
- Measure the absorbance at the appropriate wavelength (e.g., 625 nm for the Berthelot method).
- Data Analysis:
 - Calculate the percentage of urease inhibition for each concentration of **Urease-IN-14** using the following formula: % Inhibition = $[(\text{Absorbance of control} - \text{Absorbance of sample}) / \text{Absorbance of control}] \times 100$
 - Plot the % inhibition against the logarithm of the inhibitor concentration to determine the IC50 value.

Visualizations

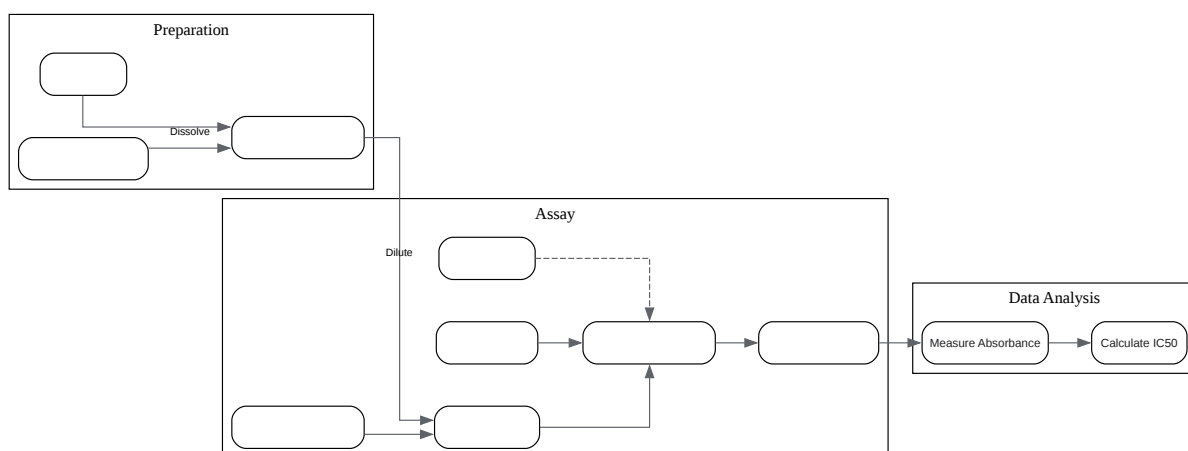

[Click to download full resolution via product page](#)

Caption: Experimental workflow for testing **Urease-IN-14** inhibitory activity.

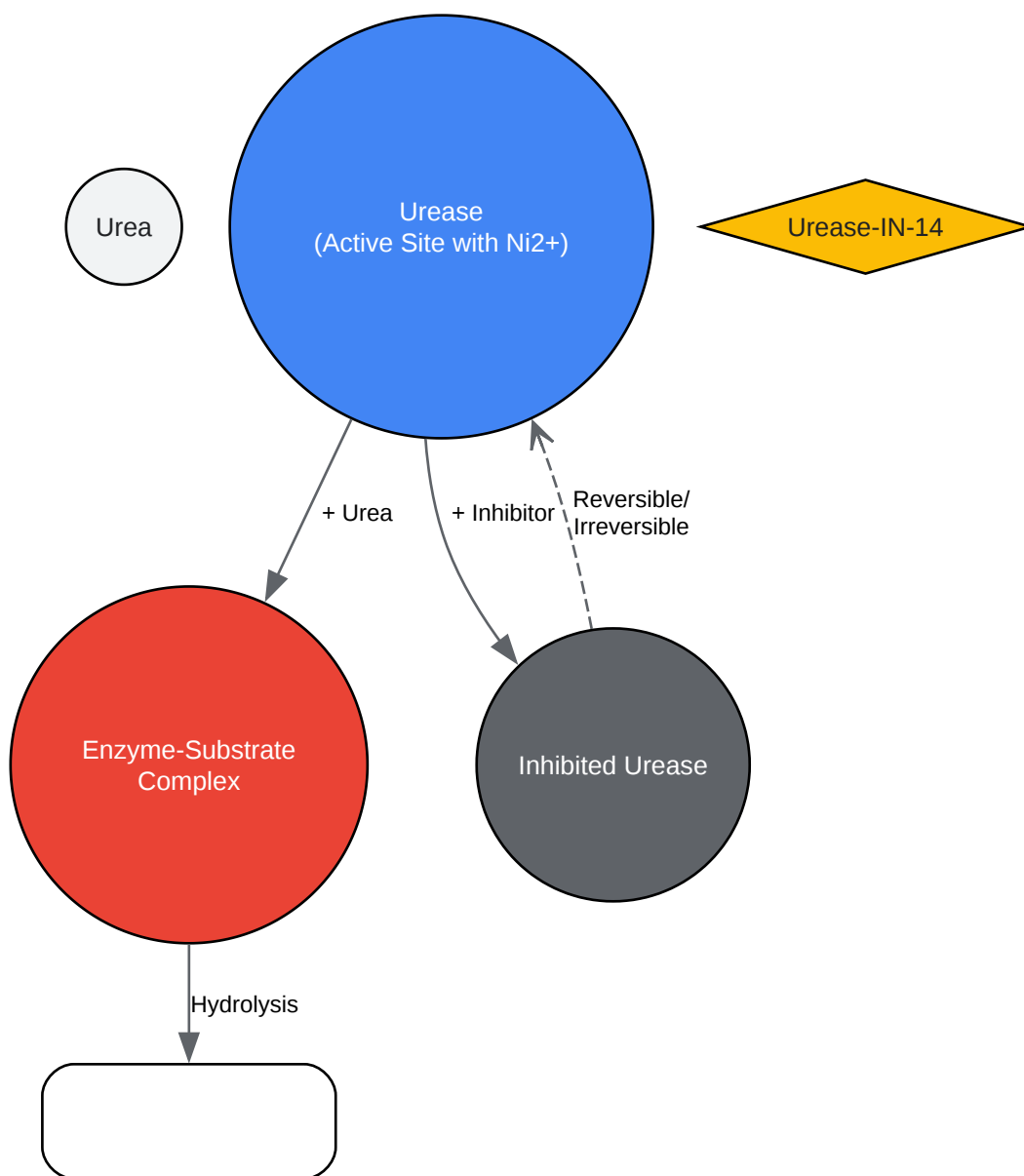

[Click to download full resolution via product page](#)

Caption: Simplified signaling pathway of urease action and its inhibition.

Need Custom Synthesis?

BenchChem offers custom synthesis for rare earth carbides and specific isotopic labeling.

Email: info@benchchem.com or [Request Quote Online](#).

References

- [1. pubs.acs.org \[pubs.acs.org\]](https://pubs.acs.org)
- To cite this document: BenchChem. [Troubleshooting Urease-IN-14 insolubility issues]. BenchChem, [2026]. [Online PDF]. Available at: [<https://www.benchchem.com/product/b10815107/docs#troubleshooting-urease-in-14-insolubility-issues>]

Disclaimer & Data Validity:

The information provided in this document is for Research Use Only (RUO) and is strictly not intended for diagnostic or therapeutic procedures. While BenchChem strives to provide accurate protocols, we make no warranties, express or implied, regarding the fitness of this product for every specific experimental setup.

Technical Support: The protocols provided are for reference purposes. Unsure if this reagent suits your experiment?

Need Industrial/Bulk Grade? [Request Custom Synthesis Quote](#)

BenchChem

Our mission is to be the trusted global source of essential and advanced chemicals, empowering scientists and researchers to drive progress in science and industry.

Contact

Address: 3281 E Guasti Rd
Ontario, CA 91761, United States
Phone: (601) 213-4426
Email: info@benchchem.com

[Contact our Ph.D. Support Team for a compatibility check](#)