

Technical Support Center: Avoiding Polymerization in Radical Generation

Author: BenchChem Technical Support Team. **Date:** April 2026

Compound of Interest

Compound Name: *1-Butyl radical*

CAS No.: *2492-36-6*

Cat. No.: *B10814794*

[Get Quote](#)

Welcome to the Technical Support Center for radical generation. This resource is designed for researchers, scientists, and drug development professionals to troubleshoot and resolve common issues encountered during radical-mediated reactions, with a specific focus on preventing undesired polymerization.

Troubleshooting Guides

Uncontrolled polymerization is a frequent challenge in radical chemistry. This guide provides a systematic approach to identifying and resolving these issues.

Issue 1: Unwanted Polymerization Observed During Radical Reaction

Your reaction mixture becomes viscous, forms a precipitate, or yields a polymer instead of the desired product.

Observation	Potential Cause	Recommended Solution
Rapid, uncontrolled polymerization upon initiation.	Excessive Radical Concentration: The rate of initiation is too high, leading to rapid chain growth and termination.	- Reduce Initiator Concentration: Decrease the amount of radical initiator by 10-50%. - Lower Reaction Temperature: Reduce the temperature by 5-10 °C to decrease the rate of initiator decomposition.
Polymerization occurs before the intended reaction.	Monomer Instability: The monomer is inherently unstable and prone to self-polymerization, especially at elevated temperatures or upon exposure to light.	- Add an Inhibitor: Introduce a suitable inhibitor to the monomer solution. Common choices include Butylated Hydroxytoluene (BHT) at approximately 0.01% by weight or the monomethyl ether of hydroquinone (MEHQ) at around 200 ppm.[1] - Store Monomers Properly: Keep monomers refrigerated or frozen and protected from light.
Inconsistent polymerization between batches.	Variable Reagent Purity: Impurities in the monomer, solvent, or initiator can act as unintended initiators or interfere with controlled polymerization processes.	- Purify Reagents: Ensure all starting materials and solvents are of high purity and are appropriately dried.[2] - Degas Solvents: Remove dissolved oxygen, which can sometimes initiate polymerization at higher temperatures, by sparging with an inert gas like nitrogen or argon.[3]
Broad or bimodal molecular weight distribution in	Poor Control over Polymerization: In techniques like ATRP or RAFT, this can be	- Optimize [Monomer]:[CTA] or [Monomer]:[Initiator] Ratio: Adjust the ratios to better

Controlled Radical
Polymerization (CRP).

due to inefficient chain transfer,
catalyst poisoning, or
inappropriate reaction
conditions.

control chain growth. - Select a
More Appropriate RAFT Agent
or ATRP Ligand: The choice of
controlling agent is crucial for
monomer compatibility.[3] -
Check for Impurities: As
mentioned above, impurities
can significantly disrupt
controlled polymerization.[2]

Frequently Asked Questions (FAQs)

Q1: What is the fundamental mechanism of radical polymerization that I am trying to avoid?

A1: Radical polymerization is a chain reaction consisting of three main steps: initiation, propagation, and termination.[4]

- Initiation: A radical initiator generates free radicals.
- Propagation: These radicals react with monomer units to form growing polymer chains.
- Termination: The growth of polymer chains is halted, typically by the combination of two radicals. The goal in avoiding unwanted polymerization is to prevent the propagation step from occurring with your desired radical species or monomer.

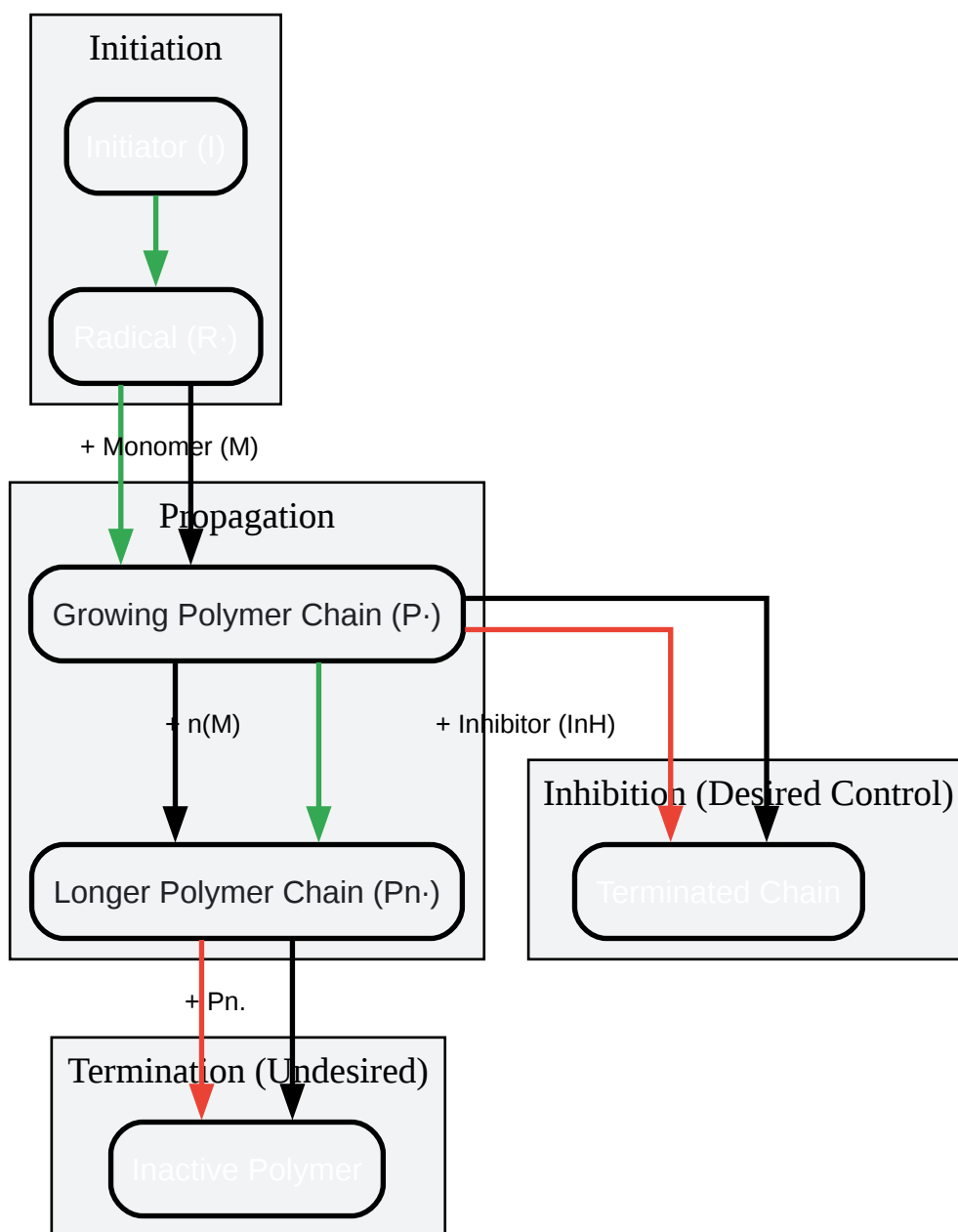

[Click to download full resolution via product page](#)

Caption: Mechanism of radical polymerization and inhibition.

Q2: How do polymerization inhibitors work?

A2: Polymerization inhibitors are compounds that react with and deactivate free radicals, thereby preventing the initiation or propagation of polymerization.[5] They are often radical scavengers. For many common inhibitors, such as those based on hydroquinone, the presence

of dissolved oxygen is necessary for their effectiveness. The time during which an inhibitor prevents polymerization is known as the induction period.[5]

Q3: My reaction is very sensitive to air. What is the role of oxygen?

A3: Oxygen can have a dual role in radical reactions. At lower temperatures, it acts as an inhibitor by reacting with carbon-centered radicals to form less reactive peroxy radicals.[6] This is often referred to as oxygen inhibition. However, at higher temperatures (e.g., above 140 °C for some acrylates), oxygen can act as an initiator, accelerating polymerization.[3] Therefore, for controlled radical generation, it is crucial to degas the reaction mixture, typically by sparging with an inert gas like nitrogen or argon.

Q4: I've added an inhibitor, but now my desired radical reaction is too slow. What should I do?

A4: This indicates that the inhibitor is also reacting with the radicals involved in your desired reaction.

- **Decrease Inhibitor Concentration:** Titrate the inhibitor concentration to find a balance where it prevents unwanted polymerization but allows your desired reaction to proceed at an acceptable rate.
- **Increase Initiator Concentration:** A higher initiator concentration may overcome the effect of the inhibitor. However, this should be done cautiously to avoid runaway reactions.[7]
- **Change the Inhibitor:** Some inhibitors are more selective than others. Research an inhibitor that is less likely to interfere with your specific radical chemistry.

Q5: When should I consider using a Controlled Radical Polymerization (CRP) technique?

A5: If you are trying to synthesize a polymer with a well-defined molecular weight and a narrow molecular weight distribution, or if you are working with monomers that are highly prone to uncontrolled polymerization, you should use a CRP technique like Atom Transfer Radical Polymerization (ATRP) or Reversible Addition-Fragmentation chain Transfer (RAFT) polymerization.[8] These methods maintain a very low concentration of active radicals at any given time, thus minimizing termination reactions.

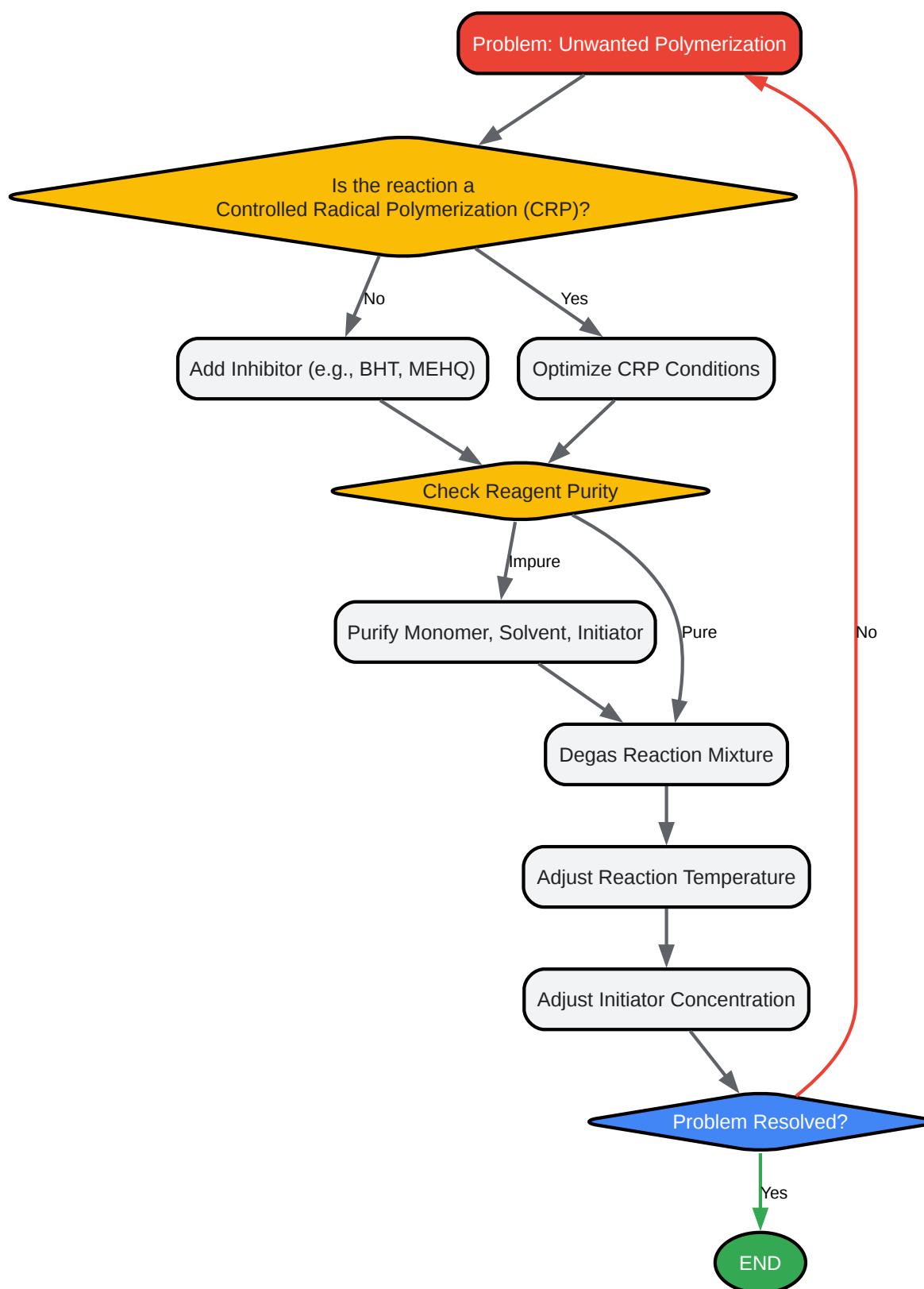

[Click to download full resolution via product page](#)

Caption: Troubleshooting workflow for unwanted polymerization.

Experimental Protocols

Protocol 1: General Procedure for Inhibiting Polymerization in Acrylic Monomers During Storage

This protocol describes the standard procedure for adding an inhibitor to an acrylic monomer for safe storage.

Materials:

- Acrylic monomer (e.g., methyl methacrylate, acrylic acid)
- Inhibitor: 4-methoxyphenol (MEHQ) or butylated hydroxytoluene (BHT)
- Amber glass bottle for storage

Procedure:

- Determine the required amount of inhibitor. For MEHQ, a typical concentration is 200 ppm. For BHT, a concentration of 0.01% by weight is common.[\[1\]](#)
- Dissolve the inhibitor in a small amount of the monomer. Ensure complete dissolution.
- Add the inhibitor solution to the bulk monomer.
- Mix thoroughly to ensure a homogeneous distribution of the inhibitor.
- Store the inhibited monomer in a tightly sealed amber glass bottle in a cool, dark place. For long-term storage, refrigeration is recommended.

Protocol 2: Example of a Controlled Radical Polymerization: ARGET ATRP of Methyl Methacrylate (MMA)

This protocol is an example of an Activators Regenerated by Electron Transfer (ARGET) Atom Transfer Radical Polymerization (ATRP) of methyl methacrylate, which minimizes unwanted polymerization and allows for the synthesis of a well-defined polymer.[\[9\]](#)

Materials:

- Methyl methacrylate (MMA), inhibitor removed
- Copper(II) bromide (CuBr₂), catalyst
- N,N,N',N'',N'''-Pentamethyldiethylenetriamine (PMDETA), ligand
- Methyl 2-chloropropionate (MCP), initiator
- Ascorbic acid, reducing agent
- Toluene, solvent
- Schlenk tube and magnetic stir bar
- Nitrogen or argon gas for degassing

Procedure:

- Catalyst/Ligand Complex Formation:
 - To a dry Schlenk tube equipped with a magnetic stir bar, add CuBr₂ (0.1115 g, 0.50 mmol) and PMDETA (0.1298 g, 0.75 mmol).
 - Seal the tube with a rubber septum.
 - Inject methanol (2 g) into the Schlenk tube to dissolve the catalyst and ligand.
 - Stir the mixture for 10 minutes to form the complex.
- Reaction Mixture Preparation:
 - In a separate vial, prepare a solution of MMA (5 g, 0.05 mol) and MCP (0.0612 g, 0.50 mmol).
 - Inject this solution into the Schlenk tube containing the catalyst/ligand complex.
- Initiation of Polymerization:

- With continuous stirring, inject toluene (5 g) and ascorbic acid (0.5 g, 2.83 mmol) into the Schlenk tube to start the polymerization.
- Polymerization:
 - For polymerization at elevated temperatures, place the Schlenk tube in a preheated oil bath.
 - Monitor the reaction progress by taking aliquots at regular intervals and analyzing for monomer conversion (e.g., by ^1H NMR or GC) and polymer molecular weight (by GPC).
- Termination:
 - To stop the polymerization, open the flask and expose the catalyst to air. The polymer can then be precipitated in a non-solvent like cold methanol or hexane and dried under vacuum.

Need Custom Synthesis?

BenchChem offers custom synthesis for rare earth carbides and specific isotopic labeling.

Email: info@benchchem.com or [Request Quote Online](#).

References

- [1. files01.core.ac.uk](http://files01.core.ac.uk) [files01.core.ac.uk]
- [2. pubs.acs.org](http://pubs.acs.org) [pubs.acs.org]
- [3. Atom Transfer Radical Polymerization \(ATRP\) and Reversible Addition-Fragmentation Chain-Transfer \(RAFT\) Polymerization | TCI Deutschland GmbH](https://www.tcichemicals.com) [[tcichemicals.com](https://www.tcichemicals.com)]
- [4. benchchem.com](http://benchchem.com) [benchchem.com]
- [5. iokinetic.com](http://iokinetic.com) [iokinetic.com]
- [6. iarjset.com](http://iarjset.com) [iarjset.com]
- [7. par.nsf.gov](http://par.nsf.gov) [par.nsf.gov]
- [8. Photopolymer - Wikipedia](https://en.wikipedia.org) [en.wikipedia.org]
- [9. 14.139.213.3:8080](http://14.139.213.3:8080) [14.139.213.3:8080]

- To cite this document: BenchChem. [Technical Support Center: Avoiding Polymerization in Radical Generation]. BenchChem, [2026]. [Online PDF]. Available at: [<https://www.benchchem.com/product/b10814794/docs#technical-support-center-avoiding-polymerization-in-radical-generation>]

Disclaimer & Data Validity:

The information provided in this document is for Research Use Only (RUO) and is strictly not intended for diagnostic or therapeutic procedures. While BenchChem strives to provide accurate protocols, we make no warranties, express or implied, regarding the fitness of this product for every specific experimental setup.

Technical Support: The protocols provided are for reference purposes. Unsure if this reagent suits your experiment?

Need Industrial/Bulk Grade? [Request Custom Synthesis Quote](#)

BenchChem

Our mission is to be the trusted global source of essential and advanced chemicals, empowering scientists and researchers to drive progress in science and industry.

Contact

Address: 3281 E Guasti Rd
Ontario, CA 91761, United States
Phone: (601) 213-4426
Email: info@benchchem.com

[Contact our Ph.D. Support Team for a compatibility check](#)