

Application Notes and Protocols: 1-Butyl Radical in Organic Synthesis

Author: BenchChem Technical Support Team. **Date:** April 2026

Compound of Interest

Compound Name: 1-Butyl radical

CAS No.: 2492-36-6

Cat. No.: B10814794

[Get Quote](#)

Audience: Researchers, scientists, and drug development professionals.

Introduction

The **1-butyl radical** ($\bullet\text{CH}_2\text{CH}_2\text{CH}_2\text{CH}_3$) is a primary alkyl radical, a highly reactive intermediate with significant applications in organic synthesis.^{[1][2][3]} As a four-carbon alkyl radical, it serves as a crucial component in various synthetic transformations, including carbon-carbon bond formation, dehalogenations, and deoxygenations.^{[4][5]} Unlike its more stable tertiary and secondary isomers, the **1-butyl radical's** high reactivity stems from the unpaired electron's location on a terminal sp^3 hybridized carbon, with less hyperconjugative stabilization.^[6] Understanding its generation and reactivity allows for the strategic construction of complex molecular architectures. This document provides an overview of its applications, quantitative data for key reactions, and detailed experimental protocols.

Generation of the 1-Butyl Radical

The transient nature of the **1-butyl radical** necessitates its in-situ generation.^[7] The most common methods involve the homolytic cleavage of a precursor molecule, often in a chain reaction mechanism.

Common Precursors and Methods:

- From Tributyltin Hydride (Bu_3SnH): This is one of the most prevalent methods. A radical initiator, such as azobisisobutyronitrile (AIBN) or triethylborane (Et_3B), is used to generate a tributyltin radical ($\text{Bu}_3\text{Sn}\cdot$). This radical can then participate in various reactions, but it is important to note that Bu_3SnH is primarily a source for the tributyltin radical, which then generates the desired carbon-centered radical (e.g., from an alkyl halide). To generate the **1-butyl radical** specifically, one would typically start with a 1-halobutane and a radical initiator system that doesn't involve a tin hydride directly abstracting the halogen. However, in many contexts, "butyl radical" chemistry implicitly uses the Bu_3SnH /AIBN system to mediate reactions where a butyl group might be part of the substrate or desired product. For clarity, the generation of a generic alkyl radical from an alkyl halide using the Bu_3SnH /AIBN system is a foundational concept.[\[4\]](#)[\[8\]](#)
- From Organic Nitrites: The pyrolysis or photolysis of organic nitrites, such as butyl nitrite, can lead to the homolytic cleavage of the O-NO bond, providing a clean source of butyl radicals. [\[9\]](#)
- Photoredox Catalysis: Modern methods utilize photoredox catalysis for the single-electron oxidation of precursors like bicyclo[1.1.0]butanes to generate related radical cations, showcasing an evolving strategy for creating reactive intermediates.[\[10\]](#)

A common initiation process using AIBN and a tin hydride is illustrated below.

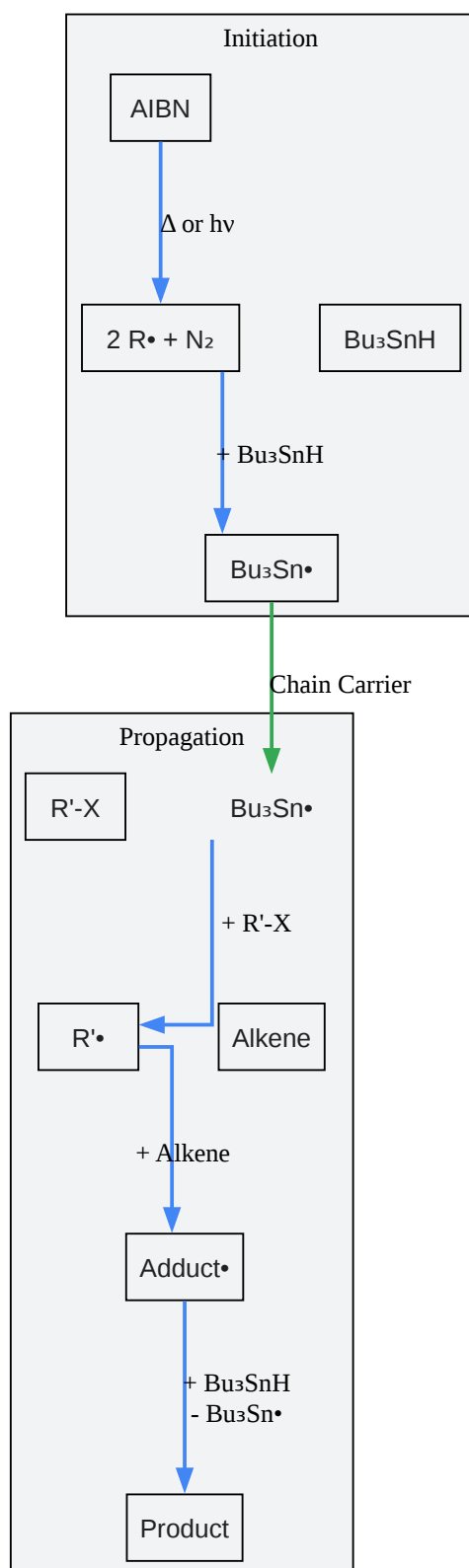

[Click to download full resolution via product page](#)

Caption: Generation of a chain-carrying radical and subsequent propagation steps.

Applications in Organic Synthesis

The **1-butyl radical** is a versatile intermediate for several key transformations.

Radical-mediated C-C bond formation is a powerful tool, particularly for creating 5-membered rings, as these reactions are kinetically controlled.[4] The **1-butyl radical**, or more commonly, an alkyl radical generated in its place, can add across alkenes and alkynes in both inter- and intramolecular fashion.[4][11]

Example: Intramolecular Cyclization (5-exo-trig) An alkyl radical, generated from an appropriate halide precursor, can cyclize onto a tethered alkene. This is a cornerstone of radical chemistry for synthesizing cyclic systems.

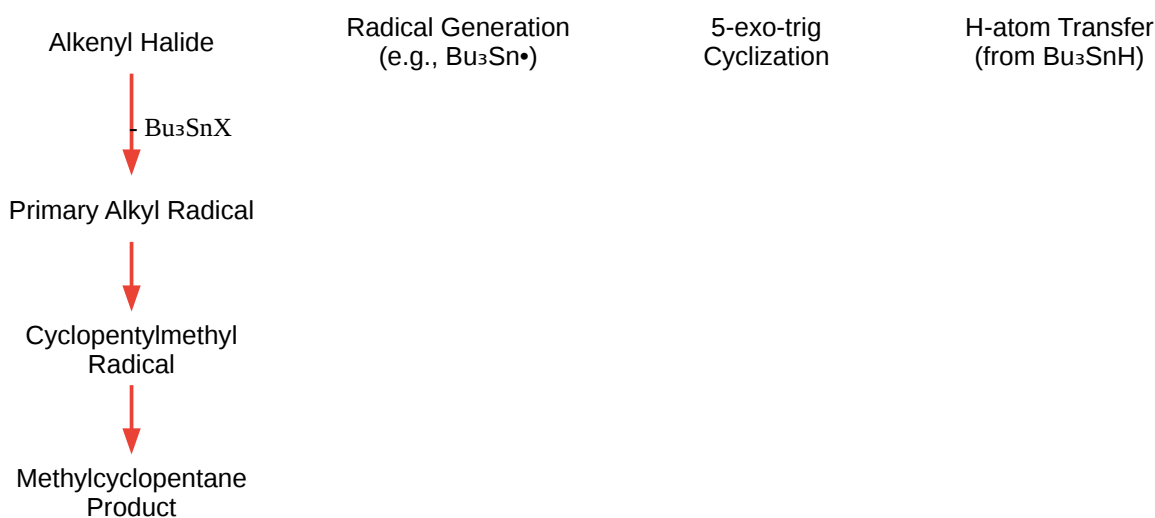

[Click to download full resolution via product page](#)

Caption: Pathway for a radical-mediated 5-exo-trig cyclization reaction.

- Dehalogenation: Tributyltin hydride is an effective reagent for the reductive dehalogenation of alkyl halides via a radical chain mechanism. The tributyltin radical abstracts a halogen atom

to generate an alkyl radical, which then abstracts a hydrogen atom from another molecule of Bu_3SnH to yield the alkane and regenerate the tin radical.[4]

- Barton-McCombie Deoxygenation: This reaction allows for the deoxygenation of alcohols. The alcohol is first converted into a thiocarbonyl derivative (e.g., a xanthate). Reaction with a radical initiator system generates a carbon-centered radical that is subsequently quenched by a hydrogen atom donor.[4][5]

Radical cascade reactions are processes where two or more consecutive radical transformations occur in a single operation, allowing for the rapid construction of molecular complexity from simple precursors.[12] These reactions are highly valuable for their step economy.[13] An initial radical can undergo a sequence of cyclizations and/or intermolecular additions before termination. The development of new radical synthons has expanded the scope of these cascades to include the synthesis of vicinal di- and tricarbonyl compounds.[14]

Quantitative Data

The efficiency of radical reactions is highly dependent on the relative rates of competing reaction pathways. The concentration of reagents is therefore a critical parameter.[7]

Table 1: Representative Rate Constants for Radical Reactions at 80 °C

Reaction Type	Example Reactants	Rate Constant (k)	Reference
Hydrogen Transfer	$\text{Bu}\cdot + \text{HSnBu}_3$	$6.2 \times 10^6 \text{ M}^{-1}\text{s}^{-1}$	[7]
Iodine Transfer	$\text{Bu}\cdot + \text{I-CH}_2\text{CO}_2\text{Et}$	$4.7 \times 10^7 \text{ M}^{-1}\text{s}^{-1}$	[7]
Alkene Addition	$\text{t-Bu}\cdot + \text{PhCH=CH}_2$	$3.0 \times 10^5 \text{ M}^{-1}\text{s}^{-1}$	[7]

| 5-exo-trig Cyclization | Hex-5-enyl radical | $1.5 \times 10^6 \text{ s}^{-1}$ |[7] |

Table 2: Typical Reaction Conditions and Yields

Reaction	Substrate	Reagents	Solvent	Temp.	Yield (%)	Reference
Deoxygenation	Secondary Alcohol Xanthate	Bu ₃ SnH (1.5 eq), AIBN (0.2 eq)	Toluene	80 °C	~85	[5]
Dehalogenation	1-Bromooctane	Bu ₃ SnH (1.2 eq), AIBN (cat.)	Benzene	Reflux	>90	[4]

| Cascade Cyclization | Acyclic diene precursor | Bu₃SnH, AIBN | Benzene | Reflux | ~60-70 [[8]

Experimental Protocols

Protocol 1: Reductive Dehalogenation of an Alkyl Bromide

This protocol describes a general procedure for the dehalogenation of an alkyl bromide using tributyltin hydride and AIBN.

Materials:

- Alkyl bromide (1.0 eq)
- Tributyltin hydride (Bu₃SnH, 1.2 eq)
- Azobisisobutyronitrile (AIBN, 0.1 eq)
- Anhydrous toluene or benzene
- Argon or Nitrogen gas supply
- Standard glassware for reflux

Procedure:

- Set up a round-bottom flask equipped with a reflux condenser and a magnetic stirrer under an inert atmosphere (Argon or Nitrogen).
- To the flask, add the alkyl bromide and anhydrous toluene (concentration of alkyl bromide typically 0.1-0.5 M).
- Add AIBN to the solution.
- In a separate flask, prepare a solution of tributyltin hydride in anhydrous toluene.
- Heat the solution containing the alkyl bromide and AIBN to reflux (80-110 °C, depending on the solvent).
- Slowly add the tributyltin hydride solution to the refluxing mixture over 1-2 hours using a syringe pump. This slow addition helps to minimize radical-radical combination reactions.^[7]
- After the addition is complete, continue to reflux the reaction mixture for an additional 2-4 hours, or until TLC/GC-MS analysis indicates complete consumption of the starting material.
- Cool the reaction mixture to room temperature.
- Quench the reaction by adding a saturated aqueous solution of KF. Stir vigorously for 1 hour to precipitate the tin byproducts as a solid (tributyltin fluoride).
- Filter the mixture through a pad of celite, washing with an organic solvent (e.g., ethyl acetate).
- Concentrate the filtrate under reduced pressure and purify the crude product by flash column chromatography.

Safety Precautions:

- Tributyltin compounds are highly toxic. Handle with extreme care in a well-ventilated fume hood and wear appropriate personal protective equipment (gloves, lab coat, safety glasses).
- AIBN is a potential explosive and should be handled with care. Upon heating, AIBN can produce tetramethylsuccinonitrile (TMSN), a highly toxic compound.^[7] Ensure the reaction is performed in a fume hood.

- Benzene is a known carcinogen. Toluene is a less toxic alternative.

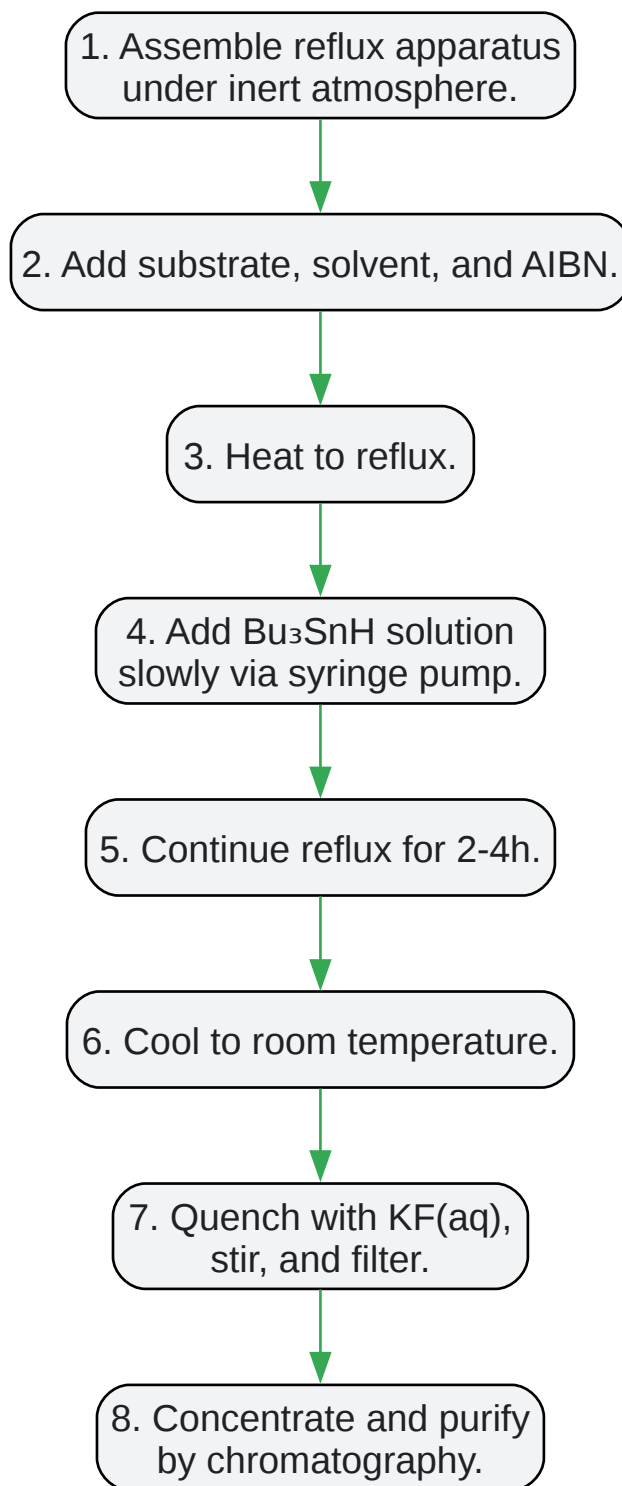

[Click to download full resolution via product page](#)

Need Custom Synthesis?

BenchChem offers custom synthesis for rare earth carbides and specific isotopic labeling.

Email: info@benchchem.com or [Request Quote Online](#).

References

- 1. 1-Butyl radical [webbook.nist.gov]
- 2. Butyl group - Wikipedia [en.wikipedia.org]
- 3. 1-Butyl radical | C₄H₉ | CID 137616 - PubChem [pubchem.ncbi.nlm.nih.gov]
- 4. chem.libretexts.org [chem.libretexts.org]
- 5. Evolution Towards Green Radical Generation in Total Synthesis - PMC [pmc.ncbi.nlm.nih.gov]
- 6. 1-Butyl radical (2492-36-6) for sale [vulcanchem.com]
- 7. ccc.chem.pitt.edu [ccc.chem.pitt.edu]
- 8. snyder-group.uchicago.edu [snyder-group.uchicago.edu]
- 9. An experimental and theoretical study of the high temperature reactions of the four butyl radical isomers - Physical Chemistry Chemical Physics (RSC Publishing) [pubs.rsc.org]
- 10. Bicyclo[1.1.0]butyl Radical Cations: Synthesis and Application to [2 π + 2 σ] Cycloaddition Reactions - PMC [pmc.ncbi.nlm.nih.gov]
- 11. assets.cambridge.org [assets.cambridge.org]
- 12. Thieme E-Books & E-Journals [thieme-connect.de]
- 13. tsijournals.com [tsijournals.com]
- 14. polymer.chem.cmu.edu [polymer.chem.cmu.edu]
- To cite this document: BenchChem. [Application Notes and Protocols: 1-Butyl Radical in Organic Synthesis]. BenchChem, [2026]. [Online PDF]. Available at: [<https://www.benchchem.com/product/b10814794/docs#application-notes-and-protocols-1-butyl-radical-in-organic-synthesis>]

Disclaimer & Data Validity:

The information provided in this document is for Research Use Only (RUO) and is strictly not intended for diagnostic or therapeutic procedures. While BenchChem strives to provide accurate protocols, we make no warranties, express or implied, regarding the fitness of this product for every specific experimental setup.

Technical Support: The protocols provided are for reference purposes. Unsure if this reagent suits your experiment?

Need Industrial/Bulk Grade? [Request Custom Synthesis Quote](#)

BenchChem

Our mission is to be the trusted global source of essential and advanced chemicals, empowering scientists and researchers to drive progress in science and industry.

Contact

Address: 3281 E Guasti Rd
Ontario, CA 91761, United States
Phone: (601) 213-4426
Email: info@benchchem.com

[Contact our Ph.D. Support Team for a compatibility check](#)