

Application Notes: Evaluating Angiogenesis with the NVP-BHG712 Isomer

Author: BenchChem Technical Support Team. **Date:** April 2026

Compound of Interest

Compound Name: NVP-BHG712 isomer

Cat. No.: B10814220

[Get Quote](#)

For Researchers, Scientists, and Drug Development Professionals

Abstract

Angiogenesis, the formation of new blood vessels, is a critical process in both normal physiology and pathological conditions such as tumor growth. Key signaling pathways, including the Vascular Endothelial Growth Factor (VEGF)/VEGFR2 and the Ephrin type-B receptor 4 (EphB4)/ephrinB2 systems, are central to regulating angiogenesis. NVP-BHG712 is a potent and selective small molecule inhibitor of the EphB4 kinase.^{[1][2]} Interestingly, studies have revealed that commercially available NVP-BHG712 is often a regioisomer (NVP-BHG712iso) with a distinct kinase selectivity profile.^{[3][4]} This compound provides a valuable tool for investigating the role of EphB4 forward signaling in angiogenesis. It has been shown to inhibit VEGF-driven angiogenesis, suggesting a significant crosstalk between the VEGFR and Eph receptor signaling pathways.^{[1][5]} These application notes provide detailed protocols for utilizing the **NVP-BHG712 isomer** in standard in vitro and in vivo angiogenesis assays.

Mechanism of Action: Targeting the EphB4/VEGFR2 Axis

NVP-BHG712 and its isomer primarily function by inhibiting the ATP-binding site of the EphB4 receptor's intracellular kinase domain. This action blocks the "forward signaling" cascade that is typically initiated upon binding of its ligand, ephrinB2.[1][6] While EphB4/ephrinB2 signaling is crucial for vascular remodeling and arteriovenous differentiation, research demonstrates that EphB4 forward signaling is also an important mediator of VEGF-induced angiogenesis.[1][7]

VEGF-A is a primary driver of angiogenesis, binding to its receptor VEGFR2 on endothelial cells to trigger proliferation, migration, and survival.[8][9][10] The inhibition of EphB4 forward signaling by the **NVP-BHG712 isomer** has been shown to be sufficient to block VEGF-driven angiogenesis in vivo, even though the compound has significantly less potent effects on VEGFR2 directly.[1] This indicates a functional crosstalk where EphB4 signaling is a downstream requirement for a full angiogenic response to VEGF.

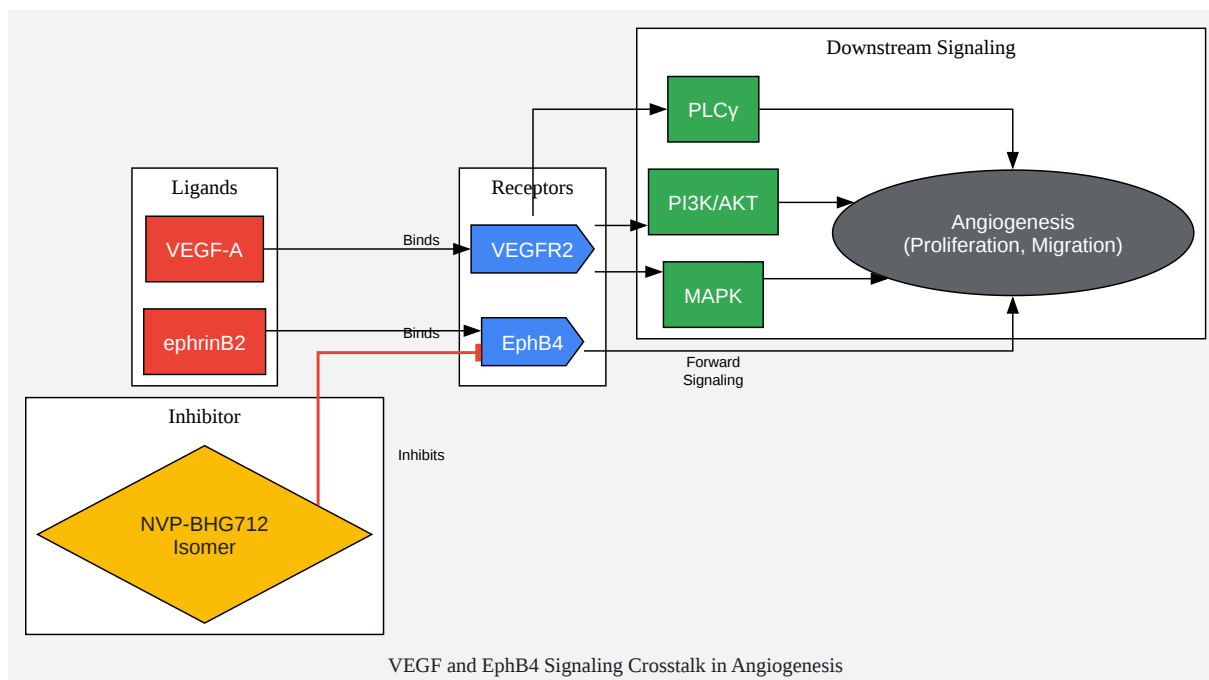

[Click to download full resolution via product page](#)

Caption: NVP-BHG712 isomer inhibits EphB4 forward signaling in angiogenesis.

Quantitative Data: Kinase Inhibition Profile

The **NVP-BHG712 isomer** demonstrates high potency for the EphB4 receptor kinase with significantly lower activity against VEGFR2 and other kinases. This selectivity makes it a useful tool to dissect the specific role of EphB4 signaling.

Target Kinase	Assay Type	Inhibitory Concentration	Reference
EphB4	Cellular Autophosphorylation	ED50 = 25 nM	[1][11]
VEGFR2	Cellular Autophosphorylation	ED50 = 4200 nM (4.2 μM)	[1][11]
c-Raf	Biochemical	IC50 = 395 nM	[11]
c-Src	Biochemical	IC50 = 1266 nM	[11]
c-Abl	Biochemical	IC50 = 1667 nM	[11]

Table 1: In vitro and cellular inhibitory activity of NVP-BHG712.

Animal Model	Treatment	Dosage	Effect	Reference
Mouse Growth Factor Implant	NVP-BHG712	3 mg/kg (p.o.)	Significantly suppressed VEGF-stimulated tissue formation and vascularization.	[11][12]
Mouse Growth Factor Implant	NVP-BHG712	10 mg/kg (p.o.)	Potently reversed VEGF-enhanced tissue formation and vessel growth.	[11][12]

Table 2: In vivo efficacy of NVP-BHG712 in angiogenesis models.

Experimental Protocols

Protocol 1: In Vitro Endothelial Cell Tube Formation Assay

This assay assesses the ability of endothelial cells to form three-dimensional, capillary-like structures when cultured on a basement membrane extract (BME), such as Matrigel®. It is a rapid method to screen for pro- or anti-angiogenic compounds.[13][14]

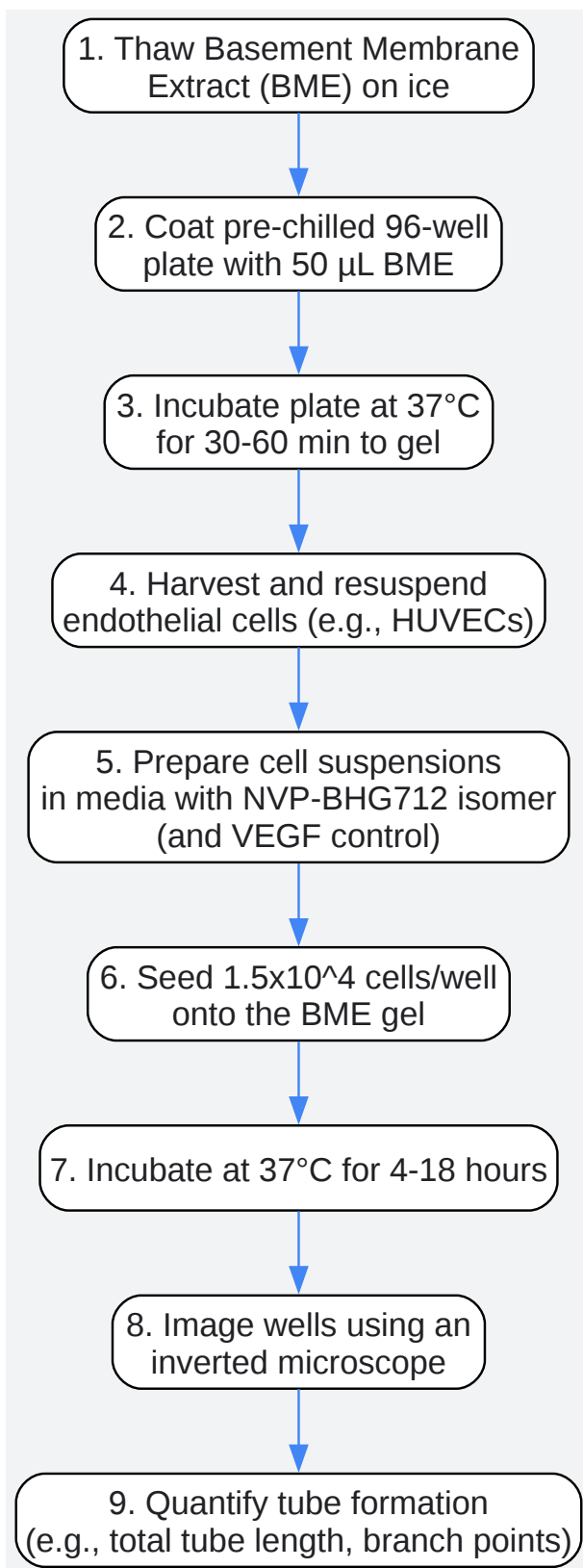

[Click to download full resolution via product page](#)

Caption: Workflow for the in vitro tube formation assay.

Detailed Methodology:

- Preparation of BME Plates:
 - Thaw Basement Membrane Extract (e.g., Matrigel®) overnight at 4°C. Keep on ice to prevent premature gelling.
 - Using pre-chilled pipette tips, add 50 µL of BME to each well of a pre-chilled 96-well plate.
 - Incubate the plate at 37°C for at least 30 minutes to allow the BME to solidify.
- Cell Preparation and Seeding:
 - Culture Human Umbilical Vein Endothelial Cells (HUVECs) to 70-90% confluency. Do not use cells beyond passage 12.[14]
 - Harvest cells using a gentle dissociation reagent (e.g., Accutase).
 - Resuspend cells in endothelial basal medium. Prepare serial dilutions of the **NVP-BHG712 isomer** in the medium. Include appropriate controls: a vehicle control (e.g., DMSO), a positive control (e.g., 20 ng/mL VEGF-A), and a test group (VEGF-A + **NVP-BHG712 isomer**).
 - Add 100 µL of the cell suspension (containing 1.0×10^4 - 1.5×10^4 cells) to each BME-coated well.
- Incubation and Analysis:
 - Incubate the plate at 37°C in a humidified 5% CO₂ incubator for 4 to 18 hours.
 - Monitor tube formation periodically under an inverted microscope.
 - Capture images of the tube networks. For quantification, use imaging software to measure parameters such as the number of nodes/junctions, the number of meshes, and the total tube length.[15]

Expected Outcome: Wells treated with VEGF-A alone should show robust tube formation. Co-treatment with the **NVP-BHG712 isomer** is expected to inhibit this tube formation in a dose-

dependent manner.

Protocol 2: In Vivo Chick Chorioallantoic Membrane (CAM) Assay

The CAM assay is a widely used in vivo model to study angiogenesis. The CAM is a highly vascularized extraembryonic membrane in the chick embryo, making it an ideal system to observe the effects of test compounds on blood vessel formation.[\[16\]](#)[\[17\]](#)

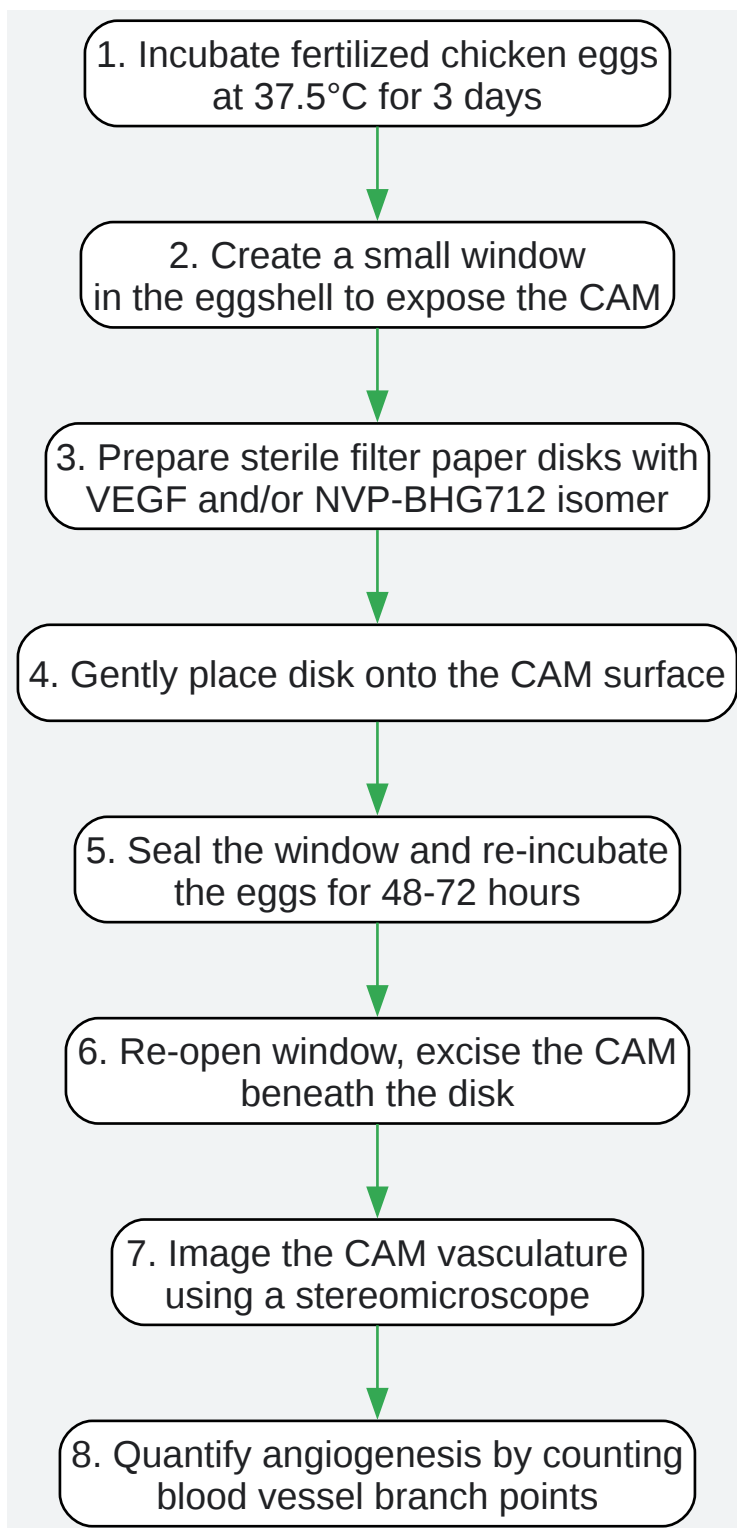

[Click to download full resolution via product page](#)

Caption: Workflow for the in vivo CAM angiogenesis assay.

Detailed Methodology:

- Egg Incubation and Windowing:
 - Incubate fertilized chicken eggs at 37.5°C in a humidified incubator for 3 days.
 - On day 3, sterilize the eggshell. Carefully create a small window (approx. 1x1 cm) in the shell over the air sac to expose the CAM without damaging it.[18]
- Compound Application:
 - Prepare sterile, 5 mm filter paper disks.
 - Saturate the disks with the test solutions: vehicle control, a positive control (e.g., 1 µg VEGF-A), and a test group (VEGF-A + **NVP-BHG712 isomer**). Allow the solvent to evaporate.
 - Gently place one disk onto the CAM surface in a region with a moderate density of blood vessels.[18]
- Re-incubation and Analysis:
 - Seal the window with sterile tape and return the eggs to the incubator for an additional 48-72 hours.
 - On the day of analysis, carefully remove the seal and flood the CAM with a fixative (e.g., methanol:acetone 1:1).
 - Excise the portion of the CAM underneath the disk, spread it on a glass slide, and photograph it under a stereomicroscope.
 - Quantify angiogenesis by counting the number of blood vessel branch points converging towards the disk.[16][18]

Expected Outcome: Disks with VEGF-A should induce a strong angiogenic response, characterized by a "spoke-wheel" pattern of new blood vessels. The **NVP-BHG712 isomer** is expected to significantly reduce the number of new vessel branches stimulated by VEGF.

Need Custom Synthesis?

BenchChem offers custom synthesis for rare earth carbides and specific isotopic labeling.

Email: info@benchchem.com or [Request Quote Online](#).

References

- 1. The small molecule specific EphB4 kinase inhibitor NVP-BHG712 inhibits VEGF driven angiogenesis - PMC [[pmc.ncbi.nlm.nih.gov](https://pubmed.ncbi.nlm.nih.gov/)]
- 2. The small molecule specific EphB4 kinase inhibitor NVP-BHG712 inhibits VEGF driven angiogenesis - PubMed [pubmed.ncbi.nlm.nih.gov]
- 3. The Pyrazolo[3,4-d]pyrimidine-Based Kinase Inhibitor NVP-BHG712: Effects of Regioisomers on Tumor Growth, Perfusion, and Hypoxia in EphB4-Positive A375 Melanoma Xenografts - PMC [[pmc.ncbi.nlm.nih.gov](https://pubmed.ncbi.nlm.nih.gov/)]
- 4. [researchgate.net](https://www.researchgate.net/) [[researchgate.net](https://www.researchgate.net/)]
- 5. [researchgate.net](https://www.researchgate.net/) [[researchgate.net](https://www.researchgate.net/)]
- 6. Essential Roles of EphB Receptors and EphrinB Ligands in Endothelial Cell Function and Angiogenesis - PMC [[pmc.ncbi.nlm.nih.gov](https://pubmed.ncbi.nlm.nih.gov/)]
- 7. EphB4 controls blood vascular morphogenesis during postnatal angiogenesis | The EMBO Journal [[link.springer.com](https://www.embojournal.org/)]
- 8. VEGF-A/VEGFR2 signaling network in endothelial cells relevant to angiogenesis - PMC [[pmc.ncbi.nlm.nih.gov](https://pubmed.ncbi.nlm.nih.gov/)]
- 9. VEGF-A/VEGFR2 signaling network in endothelial cells relevant to angiogenesis - PubMed [pubmed.ncbi.nlm.nih.gov]
- 10. [assaygenie.com](https://www.assaygenie.com/) [[assaygenie.com](https://www.assaygenie.com/)]
- 11. [selleckchem.com](https://www.selleckchem.com/) [[selleckchem.com](https://www.selleckchem.com/)]
- 12. [apexbt.com](https://www.apexbt.com/) [[apexbt.com](https://www.apexbt.com/)]
- 13. [ibidi.com](https://www.ibidi.com/) [[ibidi.com](https://www.ibidi.com/)]
- 14. [researchgate.net](https://www.researchgate.net/) [[researchgate.net](https://www.researchgate.net/)]
- 15. Endothelial Cell Tube Formation Assay for the In Vitro Study of Angiogenesis - PMC [[pmc.ncbi.nlm.nih.gov](https://pubmed.ncbi.nlm.nih.gov/)]

- [16. In vivo Chick Chorioallantoic Membrane \(CAM\) Angiogenesis Assays \[en.bio-protocol.org\]](#)
- [17. Angiogenesis Assays | Springer Nature Experiments \[experiments.springernature.com\]](#)
- [18. In vivo Chick Chorioallantoic Membrane \(CAM\) Angiogenesis Assays \[bio-protocol.org\]](#)
- To cite this document: BenchChem. [Application Notes: Evaluating Angiogenesis with the NVP-BHG712 Isomer]. BenchChem, [2026]. [Online PDF]. Available at: [\[https://www.benchchem.com/product/b10814220/docs#application-notes-evaluating-angiogenesis-with-the-nvp-bhg712-isomer\]](https://www.benchchem.com/product/b10814220/docs#application-notes-evaluating-angiogenesis-with-the-nvp-bhg712-isomer)

Disclaimer & Data Validity:

The information provided in this document is for Research Use Only (RUO) and is strictly not intended for diagnostic or therapeutic procedures. While BenchChem strives to provide accurate protocols, we make no warranties, express or implied, regarding the fitness of this product for every specific experimental setup.

Technical Support: The protocols provided are for reference purposes. Unsure if this reagent suits your experiment?

Need Industrial/Bulk Grade? [Request Custom Synthesis Quote](#)

BenchChem

Our mission is to be the trusted global source of essential and advanced chemicals, empowering scientists and researchers to drive progress in science and industry.

Contact

Address: 3281 E Guasti Rd
Ontario, CA 91761, United States
Phone: (601) 213-4426
Email: info@benchchem.com

[Contact our Ph.D. Support Team for a compatibility check](#)

