

Technical Support Center: Optimizing WAY-312084 for Hair Shaft Elongation

Author: BenchChem Technical Support Team. **Date:** April 2026

Compound of Interest

Compound Name: WAY-312084

Cat. No.: B10813771

[Get Quote](#)

Disclaimer: The following information is provided for research purposes only. **WAY-312084** is a research chemical and is not approved for human use. Due to limited publicly available data on **WAY-312084** for hair growth applications, some of the quantitative data and protocol specifics provided herein are based on studies of a closely related and more extensively researched SFRP1 inhibitor, WAY-316606. Researchers should use this information as a guide and perform their own dose-response experiments to determine the optimal concentration of **WAY-312084** for their specific experimental setup.

Frequently Asked Questions (FAQs)

Q1: What is the mechanism of action of **WAY-312084** in promoting hair shaft elongation?

A1: **WAY-312084** is believed to function as an inhibitor of Secreted Frizzled-Related Protein 1 (SFRP1). SFRP1 is a natural antagonist of the Wnt signaling pathway. By inhibiting SFRP1, **WAY-312084** effectively activates the canonical Wnt/ β -catenin signaling pathway.^{[1][2][3]} This pathway is crucial for hair follicle development, growth, and the transition of hair follicles from the resting (telogen) to the growth (anagen) phase.^{[1][2][3]} Activation of Wnt/ β -catenin signaling in the dermal papilla cells of the hair follicle is thought to stimulate the proliferation of hair matrix keratinocytes, leading to increased hair shaft production and elongation.

Q2: What is a recommended starting concentration for **WAY-312084** in hair follicle organ culture experiments?

A2: Based on studies with the related compound WAY-316606, a starting concentration of 2 μM is recommended for ex vivo human hair follicle organ culture.[1] However, it is critical to perform a dose-response study to determine the optimal concentration of **WAY-312084** for your specific experimental conditions. A suggested range for such a study would be from 0.1 μM to 10 μM .

Q3: What is the expected effect of **WAY-312084** on hair shaft elongation in culture?

A3: In ex vivo cultures of human hair follicles, treatment with an effective concentration of an SFRP1 inhibitor is expected to significantly increase hair shaft elongation over a period of 6-9 days compared to vehicle-treated controls. Studies on WAY-316606 have shown a noticeable increase in hair growth within this timeframe.[1]

Q4: How should I prepare a stock solution of **WAY-312084**?

A4: **WAY-312084** is typically soluble in organic solvents such as Dimethyl Sulfoxide (DMSO). To prepare a stock solution, dissolve the powdered compound in DMSO to a high concentration (e.g., 10 mM). This stock solution can then be further diluted in the hair follicle culture medium to the desired final working concentration. Ensure the final concentration of DMSO in the culture medium is low (typically $\leq 0.1\%$) to avoid solvent-induced toxicity.

Q5: Are there any known off-target effects or toxicity concerns with **WAY-312084**?

A5: There is limited publicly available toxicology data specifically for **WAY-312084**. As with any experimental compound, it is crucial to handle it with appropriate safety precautions. For the related compound WAY-316606, it has been reported to be well-tolerated in the context of ex vivo hair follicle culture.[1] However, researchers should consult the Material Safety Data Sheet (MSDS) for **WAY-312084** and perform their own cytotoxicity assays to determine a safe and effective concentration range for their experiments.

Troubleshooting Guide

Issue	Possible Cause(s)	Suggested Solution(s)
<p>No significant increase in hair shaft elongation with WAY-312084 treatment.</p>	<p>1. Suboptimal concentration of WAY-312084.2. Poor viability of isolated hair follicles.3. Inadequate culture conditions.4. Degradation of the compound.</p>	<p>1. Perform a dose-response experiment (e.g., 0.1 μM, 1 μM, 2 μM, 5 μM, 10 μM) to find the optimal concentration.2. Ensure careful microdissection of anagen VI hair follicles. Use follicles promptly after isolation.3. Verify the composition and pH of the culture medium. Ensure proper incubation temperature and gas mixture.4. Prepare fresh stock solutions of WAY-312084. Store the stock solution at -20°C or as recommended by the supplier.</p>
<p>Hair follicles are prematurely entering the catagen (regression) phase.</p>	<p>1. Stress to the hair follicles during isolation or culture.2. Insufficient nutrients in the culture medium.3. Presence of inhibitory factors in the serum (if used).</p>	<p>1. Handle hair follicles gently during microdissection. Minimize the time between isolation and culture.2. Use a supplemented culture medium, such as Williams' E medium with insulin, hydrocortisone, and L-glutamine.3. Use serum-free medium to avoid the influence of unknown serum factors.</p>
<p>High variability in hair shaft elongation between replicate follicles.</p>	<p>1. Inconsistent staging of isolated hair follicles (i.e., not all are in the anagen VI phase).2. Variation in the initial length of the hair follicles.3. Inconsistent treatment application.</p>	<p>1. Carefully select only anagen VI hair follicles for your experiments.2. Normalize the hair shaft elongation data to the initial length of each follicle at day 0.3. Ensure accurate and consistent pipetting of</p>

WAY-312084 and vehicle controls.

Signs of cytotoxicity in the hair follicle culture (e.g., cell death, morphological changes).

1. WAY-312084 concentration is too high.
2. High concentration of the solvent (e.g., DMSO).
3. Contamination of the culture.

1. Reduce the concentration of WAY-312084. Perform a cytotoxicity assay (e.g., MTT or LDH assay) to determine the IC₅₀.
2. Ensure the final DMSO concentration in the culture medium is non-toxic ($\leq 0.1\%$).
3. Maintain sterile techniques throughout the experimental procedure. Check for signs of microbial contamination.

Data Presentation

Table 1: Effect of WAY-316606 on Human Hair Shaft Elongation (ex vivo)

Data based on a study of the related SFRP1 inhibitor, WAY-316606.

Treatment	Concentration	Mean Hair Shaft Elongation (mm) at Day 6	Percentage Increase vs. Control
Vehicle Control (DMSO)	0.1%	1.5 ± 0.2	-
WAY-316606	2 μM	2.5 ± 0.3	~67%

Note: The above data is illustrative and based on published findings for WAY-316606. Actual results with **WAY-312084** may vary.

Experimental Protocols

Protocol 1: Ex Vivo Human Hair Follicle Organ Culture

- Hair Follicle Isolation:
 - Obtain human scalp skin samples from consenting donors (e.g., from facelift or hair transplant surgery).
 - Store the tissue in a sterile, supplemented Williams' E medium on ice.
 - Under a dissecting microscope, carefully microdissect individual anagen VI hair follicles from the subcutaneous fat.
 - Isolate the follicles at the level of the dermal papilla.
- Hair Follicle Culture:
 - Place one isolated hair follicle per well in a 24-well plate containing 1 ml of supplemented Williams' E medium (containing L-glutamine, insulin, and hydrocortisone).
 - Incubate the plate at 37°C in a humidified atmosphere with 5% CO₂.
- Treatment with **WAY-312084**:
 - Prepare a stock solution of **WAY-312084** in DMSO (e.g., 10 mM).
 - On day 1 of culture, replace the medium with fresh medium containing the desired concentration of **WAY-312084** or the vehicle control (DMSO at the same final concentration).
 - Change the medium every 2 days with freshly prepared treatment or control medium.
- Measurement of Hair Shaft Elongation:
 - At day 0 (after isolation) and subsequently every 2-3 days, capture a digital image of each hair follicle using an inverted microscope with a calibrated imaging system.
 - Measure the length of the hair shaft from the base of the hair bulb to the tip of the hair shaft.

- Calculate the net hair shaft elongation by subtracting the initial length at day 0 from the length at each time point.

Protocol 2: Wnt/ β -catenin Signaling Activation Assay (TOP/FOP Flash Reporter Assay)

- Cell Culture and Transfection:
 - Culture human dermal papilla cells (DPCs) in an appropriate growth medium.
 - Co-transfect the DPCs with a TCF/LEF-responsive luciferase reporter plasmid (TOP-Flash) and a control plasmid with mutated TCF/LEF binding sites (FOP-Flash). A Renilla luciferase plasmid should also be co-transfected for normalization.
- Treatment:
 - After 24 hours of transfection, treat the cells with various concentrations of **WAY-312084** or a vehicle control.
- Luciferase Assay:
 - After 24-48 hours of treatment, lyse the cells and measure the firefly and Renilla luciferase activities using a dual-luciferase reporter assay system.
- Data Analysis:
 - Normalize the firefly luciferase activity (TOP or FOP) to the Renilla luciferase activity for each sample.
 - Calculate the fold change in TOP-Flash activity relative to the FOP-Flash activity and the vehicle-treated control to determine the extent of Wnt/ β -catenin signaling activation.

Visualizations

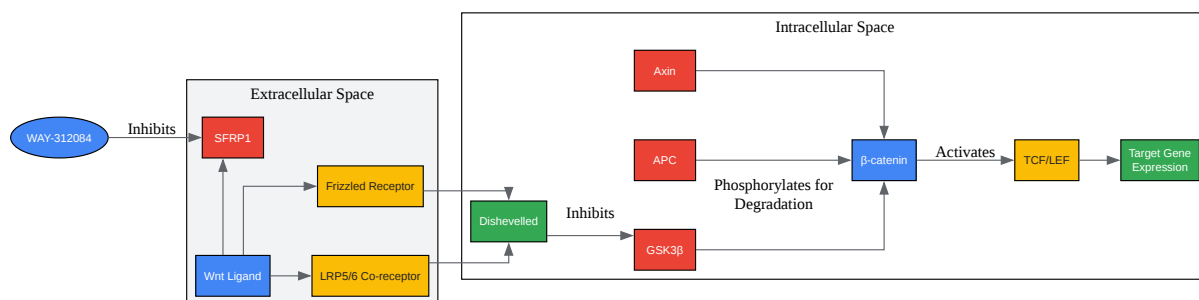

[Click to download full resolution via product page](#)

Caption: Wnt/ β -catenin signaling pathway and the inhibitory role of **WAY-312084** on SFRP1.

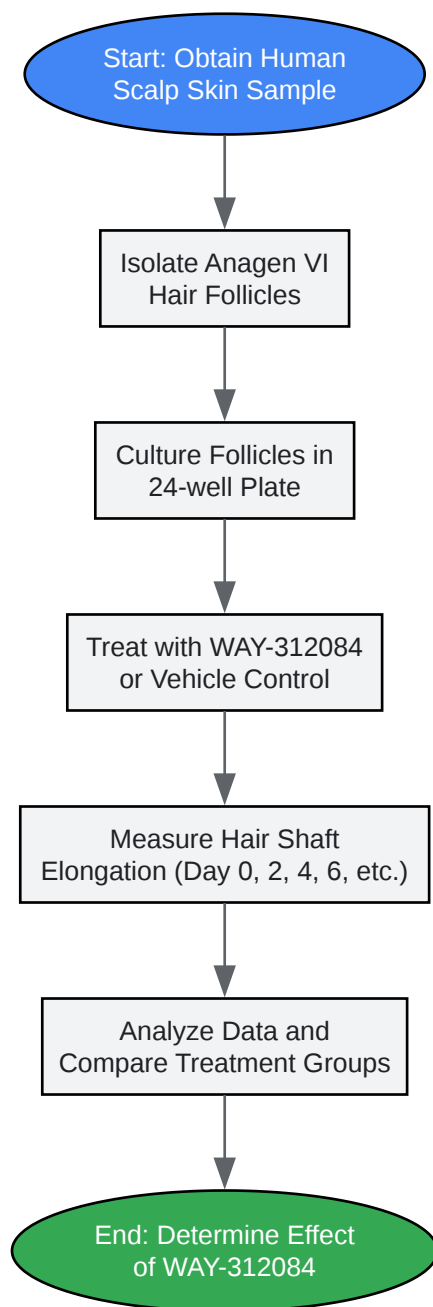

[Click to download full resolution via product page](#)

Caption: Experimental workflow for assessing the effect of **WAY-312084** on hair shaft elongation.

Need Custom Synthesis?

BenchChem offers custom synthesis for rare earth carbides and specific isotopic labeling.

Email: info@benchchem.com or [Request Quote Online](#).

References

- 1. Identifying novel strategies for treating human hair loss disorders: Cyclosporine A suppresses the Wnt inhibitor, SFRP1, in the dermal papilla of human scalp hair follicles - PMC [pmc.ncbi.nlm.nih.gov]
- 2. Osteoporosis drug found to stimulate hair follicle growth - Juta MedicalBrief [medicalbrief.co.za]
- 3. Can an SFRP1 Inhibitor Shampoo be a Real Hair Loss Cure? [hairgrowthsos.com]
- To cite this document: BenchChem. [Technical Support Center: Optimizing WAY-312084 for Hair Shaft Elongation]. BenchChem, [2026]. [Online PDF]. Available at: [https://www.benchchem.com/product/b10813771/docs#technical-support-center-optimizing-way-312084-for-hair-shaft-elongation]

Disclaimer & Data Validity:

The information provided in this document is for Research Use Only (RUO) and is strictly not intended for diagnostic or therapeutic procedures. While BenchChem strives to provide accurate protocols, we make no warranties, express or implied, regarding the fitness of this product for every specific experimental setup.

Technical Support: The protocols provided are for reference purposes. Unsure if this reagent suits your experiment?

Need Industrial/Bulk Grade? [Request Custom Synthesis Quote](#)

BenchChem

Our mission is to be the trusted global source of essential and advanced chemicals, empowering scientists and researchers to drive progress in science and industry.

Contact

Address: 3281 E Guasti Rd
Ontario, CA 91761, United States
Phone: (601) 213-4426
Email: info@benchchem.com

Contact our Ph.D. Support Team for a compatibility check