

strategies to enhance CK2-IN-8 potency

Author: BenchChem Technical Support Team. **Date:** April 2026

Compound of Interest

Compound Name: CK2-IN-8
Cat. No.: B10812363

[Get Quote](#)

Technical Support Center: CK2-IN-8

Welcome to the technical support center for **CK2-IN-8**, a potent inhibitor of Protein Kinase CK2. This resource is designed for researchers, scientists, and drug development professionals to provide troubleshooting guidance and answers to frequently asked questions encountered during experiments with **CK2-IN-8** and its analogs.

Frequently Asked Questions (FAQs)

Q1: What is the mechanism of action of **CK2-IN-8**?

CK2-IN-8 is an ATP-competitive inhibitor of Protein Kinase CK2. It binds to the ATP-binding pocket of the CK2 α catalytic subunit, preventing the phosphorylation of CK2 substrates.[1] By inhibiting CK2, it can modulate various cellular processes, including cell cycle progression, apoptosis, and DNA repair, making it a valuable tool for cancer research.[2]

Q2: I am observing lower than expected potency (high IC50 value) for **CK2-IN-8** in my in vitro kinase assay. What are the possible reasons?

Several factors could contribute to this issue:

- **ATP Concentration:** High concentrations of ATP in the assay can compete with **CK2-IN-8**, leading to an apparent decrease in potency. It is recommended to use an ATP concentration at or near the K_m value for CK2.[3]
- **Enzyme Quality and Concentration:** Ensure the recombinant CK2 enzyme is active and used at an optimal concentration. Enzyme aggregation or degradation can lead to inconsistent results.
- **Compound Solubility:** **CK2-IN-8** may have limited solubility in aqueous assay buffers. Ensure the compound is fully dissolved, and the final DMSO concentration is low and consistent across all wells (typically <1%).[4]
- **Assay Conditions:** Suboptimal buffer pH, ionic strength, or incubation time can affect enzyme activity and inhibitor binding.

Q3: My in vitro potency is high, but the inhibitor shows weak activity in cell-based assays. What could be the cause?

Discrepancies between in vitro and cellular activity are common. Potential reasons include:

- **Cell Permeability:** The compound may have poor membrane permeability, preventing it from reaching its intracellular target.
- **Cellular ATP Concentration:** The intracellular ATP concentration (millimolar range) is significantly higher than that used in most in vitro assays (micromolar range), leading to increased competition.
- **Efflux Pumps:** The compound may be a substrate for cellular efflux pumps, actively removing it from the cell.
- **Metabolism:** The compound may be rapidly metabolized by the cells into inactive forms.
- **Off-Target Effects:** In a cellular environment, the observed phenotype might be a result of the compound acting on multiple targets, not just CK2.[5]

Q4: How can I confirm that **CK2-IN-8** is engaging with CK2 inside the cell?

A Cellular Thermal Shift Assay (CETSA) is a powerful technique to verify target engagement. This method is based on the principle that a protein's thermal stability increases upon ligand binding. A shift in the melting temperature (T_m) of CK2 in the presence of **CK2-IN-8** confirms intracellular binding.

Troubleshooting Guides

Issue 1: High Variability in IC50 Values Between Experiments

Possible Cause	Troubleshooting Step	Expected Outcome
Inconsistent Reagent Preparation	Prepare fresh stock solutions of CK2-IN-8, ATP, and enzyme for each experiment. Use calibrated pipettes and ensure thorough mixing.	Reduced variability and more reproducible IC50 values.
Cell Health and Passage Number	Monitor cell morphology and use cells within a consistent, low passage number range for cellular assays.	Consistent cellular response to the inhibitor.
Assay Plate Edge Effects	Avoid using the outer wells of the microplate, or ensure proper sealing to minimize evaporation and temperature gradients.	More uniform data across the plate.

Issue 2: Compound Precipitation in Assay Buffer

Possible Cause	Troubleshooting Step	Expected Outcome
Low Compound Solubility	Visually inspect for precipitation. Determine the compound's solubility in the final assay buffer. Consider using a lower concentration or adding a solubilizing agent if compatible with the assay.	Clear solutions and reliable concentration-dependent effects.
Incorrect Solvent Concentration	Ensure the final concentration of the organic solvent (e.g., DMSO) is low and consistent across all wells.	Prevention of compound precipitation and solvent-induced artifacts.

Strategies to Enhance CK2-IN-8 Potency

Structure-Activity Relationship (SAR) studies are crucial for optimizing the potency of **CK2-IN-8**. The following strategies, based on medicinal chemistry principles for kinase inhibitors, can be employed.

Modification of the Core Scaffold

Systematic modification of the core heterocyclic scaffold of **CK2-IN-8** can lead to improved interactions with the ATP-binding pocket of CK2. Introducing different substituents can enhance binding affinity through additional hydrogen bonds, hydrophobic interactions, or by displacing water molecules.

Targeting Allosteric Pockets

Developing inhibitors that bind to allosteric sites—pockets on the kinase distinct from the ATP-binding site—can offer higher selectivity. A bivalent inhibitor strategy, where a molecule targets both the ATP site and an allosteric pocket, can significantly increase potency and selectivity.

Covalent Inhibition

Introducing a reactive group (a "warhead") to the inhibitor that can form a covalent bond with a non-conserved cysteine residue near the active site can lead to irreversible inhibition and

enhanced potency.

Hypothetical Potency Data for CK2-IN-8 Analogs

The following table summarizes hypothetical IC50 values for **CK2-IN-8** and a series of its analogs designed based on the strategies mentioned above. This data is for illustrative purposes to guide optimization efforts.

Compound	Modification Strategy	CK2 IC50 (nM)
CK2-IN-8	Parent Compound	50
CK2-IN-8-A1	Scaffold Modification (added hydroxyl group)	25
CK2-IN-8-A2	Scaffold Modification (added methyl group)	60
CK2-IN-8-B1	Allosteric Pocket Targeting Moiety	15
CK2-IN-8-C1	Covalent Warhead (acrylamide)	5

Experimental Protocols

In Vitro CK2 Kinase Assay (Luminescence-Based)

This protocol measures the amount of ATP remaining after a kinase reaction, which is inversely proportional to kinase activity.

Materials:

- Recombinant human CK2 holoenzyme
- CK2 peptide substrate (e.g., RRRADDSDDDDD)
- **CK2-IN-8** and its analogs
- ATP

- Kinase assay buffer (e.g., 25 mM HEPES pH 7.4, 10 mM MgCl₂, 1 mM DTT)
- Luminescence-based ATP detection reagent (e.g., Kinase-Glo®)
- White, opaque 96- or 384-well plates

Procedure:

- Prepare serial dilutions of **CK2-IN-8** and its analogs in DMSO, followed by a further dilution in kinase assay buffer.
- In a white microplate, add the inhibitor dilutions and controls (no inhibitor, no enzyme).
- Add the CK2 enzyme to all wells except the "no enzyme" control and incubate for 15 minutes at room temperature.
- Initiate the reaction by adding a mixture of the peptide substrate and ATP. The final ATP concentration should be close to its K_m for CK2.
- Incubate the plate at 30°C for 60 minutes.
- Stop the reaction and measure the remaining ATP by adding the luminescence-based detection reagent according to the manufacturer's instructions.
- Read the luminescence on a plate reader.
- Calculate IC₅₀ values by fitting the data to a dose-response curve.

Cellular Thermal Shift Assay (CETSA)

This protocol assesses the target engagement of **CK2-IN-8** in intact cells.

Materials:

- Cells expressing CK2
- **CK2-IN-8**
- Cell culture medium

- PBS (Phosphate-Buffered Saline)
- Lysis buffer with protease and phosphatase inhibitors
- Antibody specific for CK2 for Western blotting

Procedure:

- Treat cultured cells with either vehicle (DMSO) or **CK2-IN-8** at the desired concentration and incubate for a specified time.
- Harvest and wash the cells with PBS.
- Resuspend the cells in PBS and aliquot into PCR tubes.
- Heat the cell suspensions at a range of temperatures (e.g., 40-70°C) for 3 minutes, followed by cooling at room temperature for 3 minutes. Include a non-heated control.
- Lyse the cells by freeze-thaw cycles.
- Separate the soluble protein fraction from the precipitated protein by centrifugation.
- Analyze the soluble fractions by SDS-PAGE and Western blotting using an anti-CK2 antibody.
- Quantify the band intensities and plot them against the temperature to generate melting curves. A shift in the melting curve to a higher temperature in the presence of **CK2-IN-8** indicates target engagement.

Visualizations

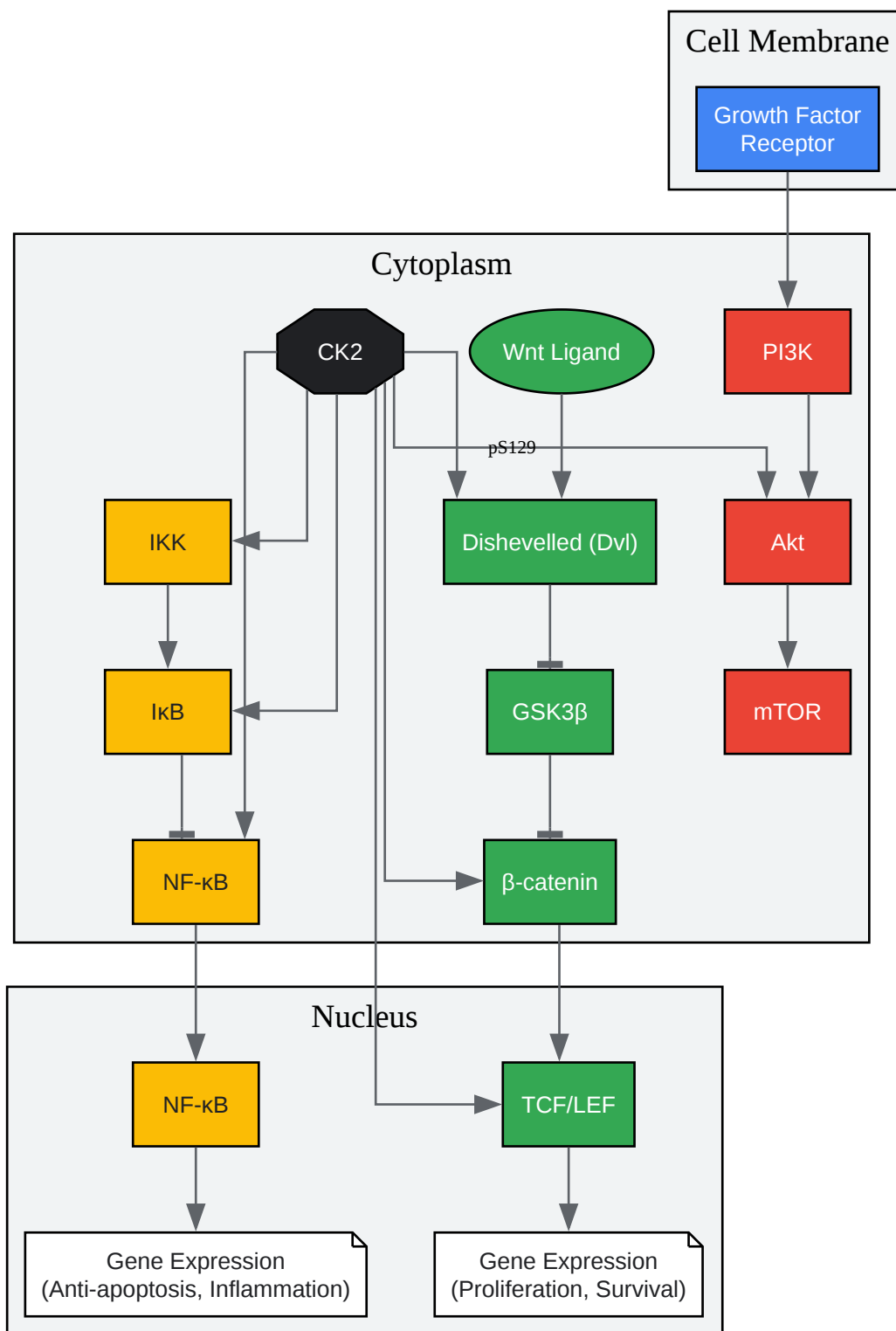

[Click to download full resolution via product page](#)

Caption: Overview of major signaling pathways regulated by CK2.

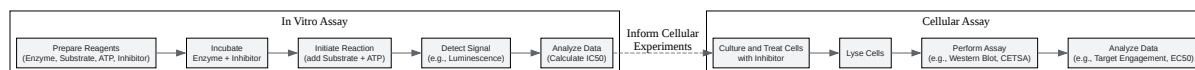

[Click to download full resolution via product page](#)

Caption: General experimental workflow for inhibitor characterization.

Need Custom Synthesis?

BenchChem offers custom synthesis for rare earth carbides and specific isotopic labeling.

Email: info@benchchem.com or [Request Quote Online](#).

References

- [1. Frontiers | Copper Modulates the Catalytic Activity of Protein Kinase CK2 \[frontiersin.org\]](#)
- [2. tandfonline.com \[tandfonline.com\]](#)
- [3. Assessing the Inhibitory Potential of Kinase Inhibitors In Vitro: Major Pitfalls and Suggestions for Improving Comparability of Data Using CK1 Inhibitors as an Example - PMC \[pmc.ncbi.nlm.nih.gov\]](#)
- [4. benchchem.com \[benchchem.com\]](#)
- [5. benchchem.com \[benchchem.com\]](#)
- To cite this document: BenchChem. [strategies to enhance CK2-IN-8 potency]. BenchChem, [2026]. [Online PDF]. Available at: [\[https://www.benchchem.com/product/b10812363/docs#strategies-to-enhance-ck2-in-8-potency\]](https://www.benchchem.com/product/b10812363/docs#strategies-to-enhance-ck2-in-8-potency)

Disclaimer & Data Validity:

The information provided in this document is for Research Use Only (RUO) and is strictly not intended for diagnostic or therapeutic procedures. While BenchChem strives to provide

accurate protocols, we make no warranties, express or implied, regarding the fitness of this product for every specific experimental setup.

Technical Support: The protocols provided are for reference purposes. Unsure if this reagent suits your experiment?

Need Industrial/Bulk Grade? [Request Custom Synthesis Quote](#)

BenchChem

Our mission is to be the trusted global source of essential and advanced chemicals, empowering scientists and researchers to drive progress in science and industry.

Contact

Address: 3281 E Guasti Rd

Ontario, CA 91761, United States

Phone: (601) 213-4426

Email: info@benchchem.com

[Contact our Ph.D. Support Team for a compatibility check](#)