

# The Impact of CK2-IN-8 on Cellular Signaling: A Technical Guide

**Author:** BenchChem Technical Support Team. **Date:** April 2026

## Compound of Interest

Compound Name: CK2-IN-8  
Cat. No.: B10812363

[Get Quote](#)

For Researchers, Scientists, and Drug Development Professionals

This technical guide provides an in-depth analysis of the effects of **CK2-IN-8**, a potent inhibitor of Protein Kinase CK2, on critical cell signaling pathways. This document outlines the molecular mechanisms through which CK2 inhibition modulates cellular processes, presents quantitative data for relevant CK2 inhibitors, details key experimental protocols, and provides visual representations of the affected signaling cascades.

## Introduction to Protein Kinase CK2

Protein Kinase CK2 (formerly Casein Kinase II) is a highly conserved and ubiquitously expressed serine/threonine kinase that plays a pivotal role in a vast array of cellular processes. [1][2] CK2 is typically found as a tetrameric complex composed of two catalytic subunits ( $\alpha$  and/or  $\alpha'$ ) and two regulatory  $\beta$  subunits. [3][4] Unlike many other kinases, CK2 is constitutively active and is implicated in the regulation of cell growth, proliferation, survival, and apoptosis. [5] Its dysregulation is frequently observed in various cancers, making it a significant target for therapeutic intervention. CK2 exerts its influence by phosphorylating a wide range of substrates, thereby modulating the activity of numerous signaling pathways crucial for tumorigenesis, including the PI3K/Akt/mTOR, NF- $\kappa$ B, and JAK/STAT pathways.

## Mechanism of Action of CK2 Inhibitors

The majority of CK2 inhibitors, including the chemical class to which **CK2-IN-8** likely belongs, function as ATP-competitive antagonists. These small molecules bind to the ATP-binding pocket of the CK2 catalytic subunits, preventing the transfer of a phosphate group from ATP to CK2 substrates. This inhibition effectively blocks CK2-mediated signaling, leading to downstream effects such as the induction of apoptosis and the suppression of pro-survival pathways.

## Effects on Key Cell Signaling Pathways

Inhibition of CK2 by compounds like **CK2-IN-8** is expected to have profound effects on several interconnected signaling networks that are fundamental to cancer cell biology.

### The PI3K/Akt/mTOR Pathway

The PI3K/Akt/mTOR pathway is a central regulator of cell growth, proliferation, and survival. CK2 positively regulates this pathway at multiple levels. It can directly phosphorylate Akt1 at serine 129, which promotes its catalytic activity. Furthermore, CK2 can phosphorylate and inhibit the tumor suppressor PTEN, a phosphatase that counteracts PI3K signaling.

Inhibition of CK2 is therefore expected to lead to a downregulation of the PI3K/Akt/mTOR pathway. This would manifest as decreased phosphorylation of Akt and its downstream targets, such as mTOR and S6 kinase.

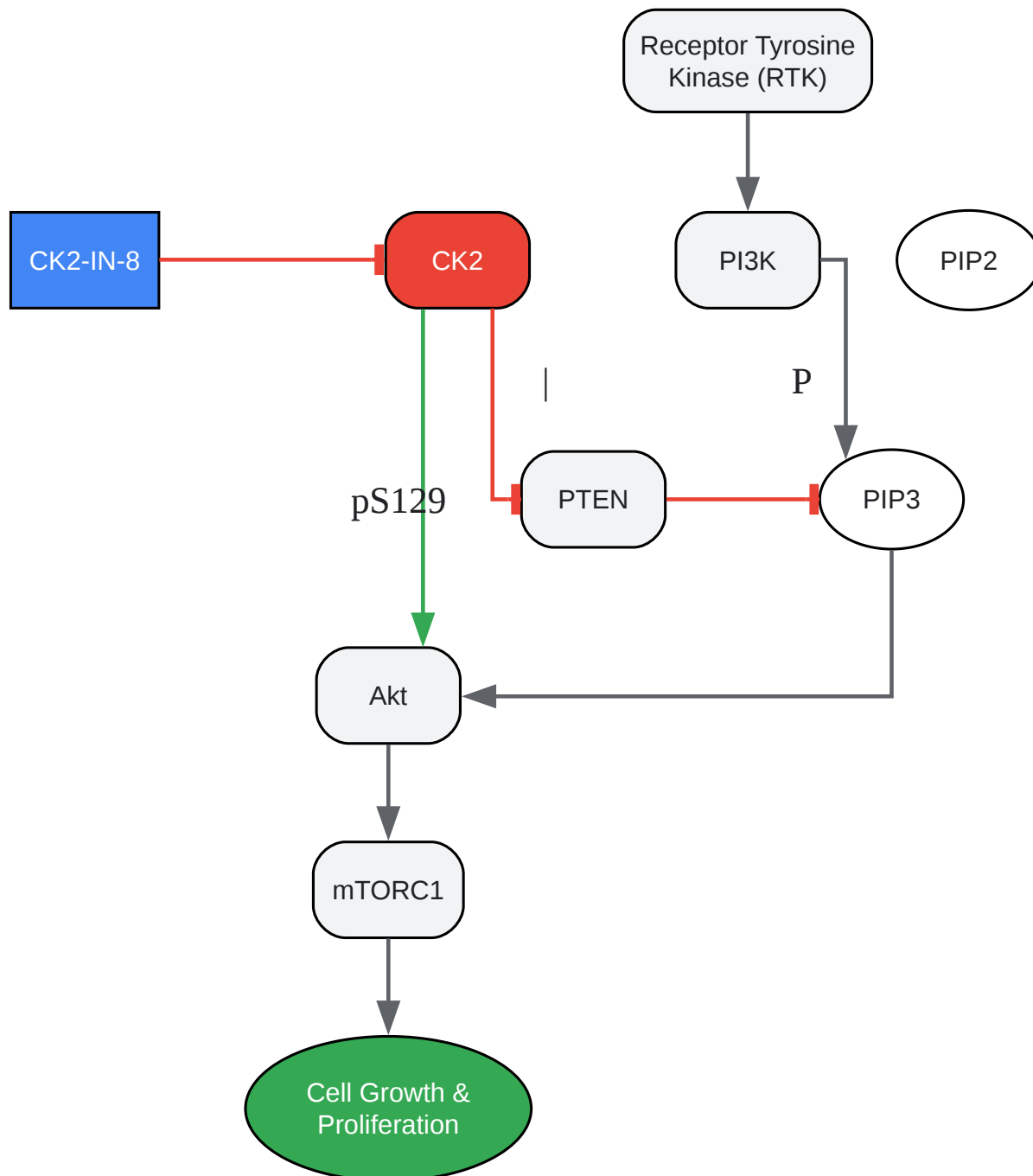

[Click to download full resolution via product page](#)

**Figure 1:** CK2-IN-8 effect on the PI3K/Akt/mTOR pathway.

## The NF-κB Signaling Pathway

The NF- $\kappa$ B (Nuclear Factor kappa-light-chain-enhancer of activated B cells) pathway is critical for inflammation, immunity, and cell survival. In many cancers, this pathway is constitutively active, promoting cell proliferation and inhibiting apoptosis. CK2 can activate the NF- $\kappa$ B pathway through multiple mechanisms, including the phosphorylation of I $\kappa$ B $\alpha$  (the inhibitor of NF- $\kappa$ B) and the direct phosphorylation of the p65/RelA subunit of NF- $\kappa$ B at serine 529. Phosphorylation of I $\kappa$ B $\alpha$  targets it for degradation, allowing NF- $\kappa$ B to translocate to the nucleus and activate target gene expression.

Inhibition of CK2 would be expected to suppress NF- $\kappa$ B activation by preventing I $\kappa$ B $\alpha$  degradation and reducing the transcriptional activity of p65.

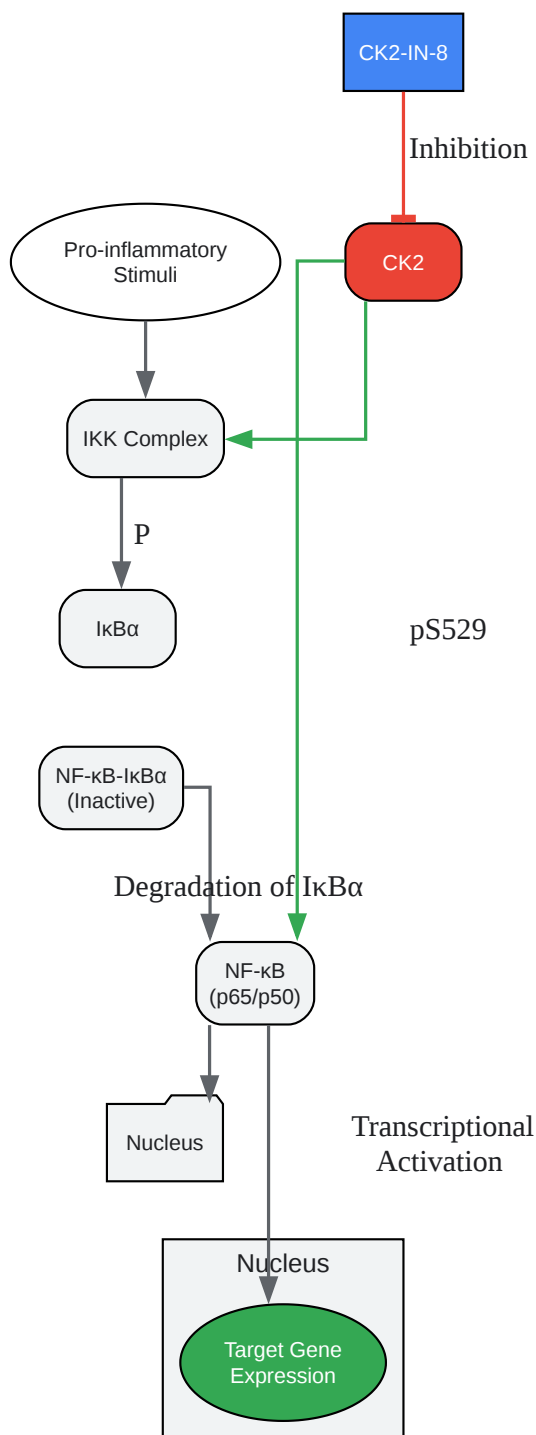

[Click to download full resolution via product page](#)

**Figure 2: CK2-IN-8 effect on the NF-κB signaling pathway.**

## The Apoptosis Pathway

CK2 is a potent suppressor of apoptosis. Its inhibition leads to the induction of programmed cell death in various cancer cell lines. The pro-apoptotic effects of CK2 inhibition are mediated, at least in part, through the mitochondrial or intrinsic apoptosis pathway. This involves a rapid decrease in the mitochondrial membrane potential, the upregulation of the pro-apoptotic protein Bax, and the downregulation of anti-apoptotic proteins like Bcl-2 and Bcl-xL. CK2 inhibition can also sensitize cancer cells to TRAIL-induced apoptosis by promoting the formation of the Death-Inducing Signaling Complex (DISC) and subsequent activation of caspase-8 and cleavage of Bid.

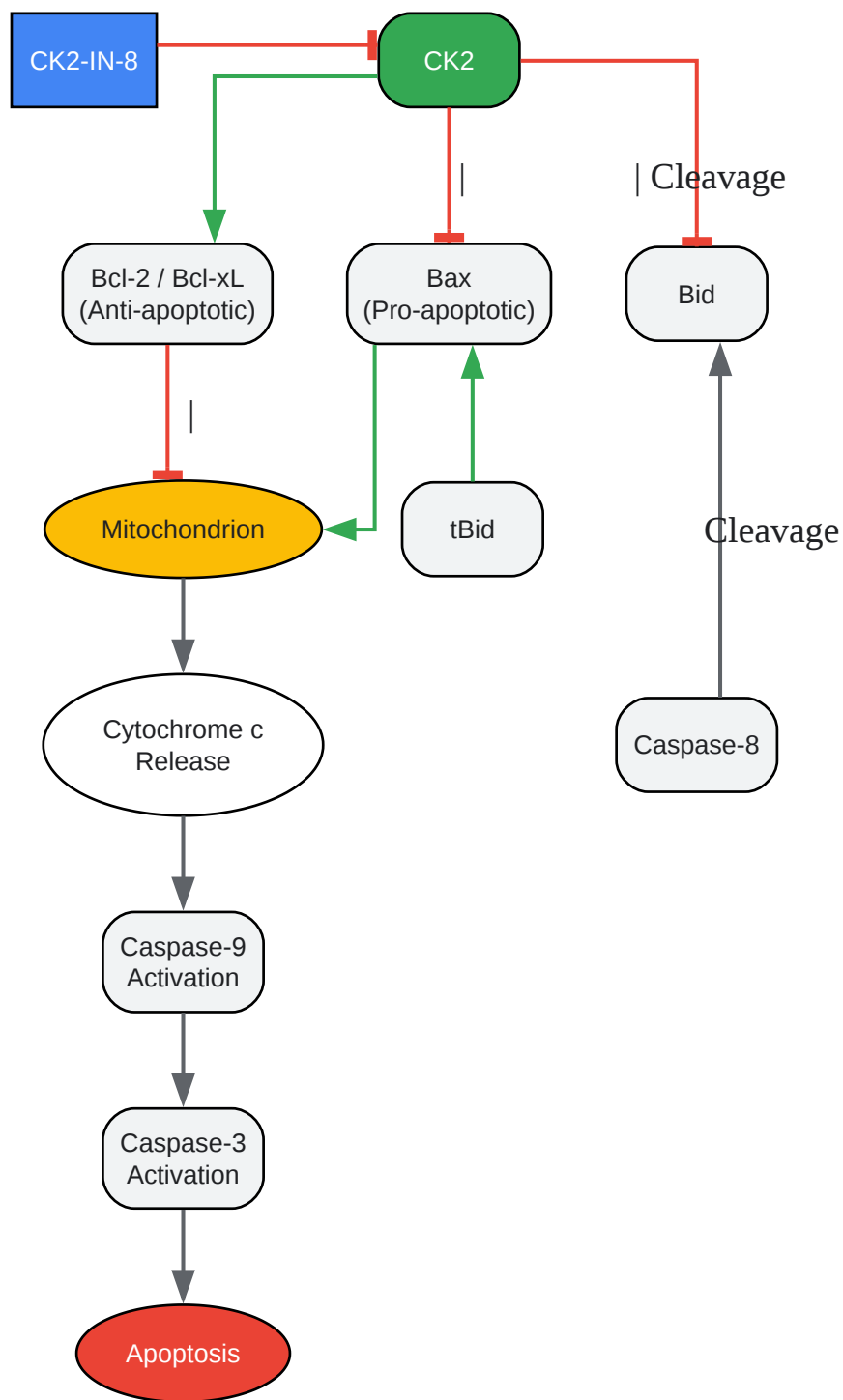

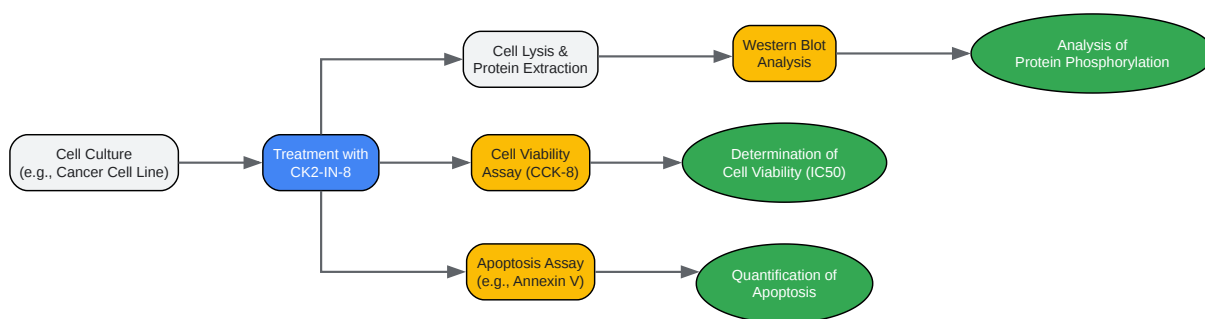

[Click to download full resolution via product page](#)

### Need Custom Synthesis?

BenchChem offers custom synthesis for rare earth carbides and specific isotopic labeling.

Email: [info@benchchem.com](mailto:info@benchchem.com) or [Request Quote Online](#).

## References

- 1. Protein Kinase CK2 - A Key Suppressor of Apoptosis - PMC [[pmc.ncbi.nlm.nih.gov](https://pubmed.ncbi.nlm.nih.gov/)]
- 2. [researchgate.net](https://www.researchgate.net/) [[researchgate.net](https://www.researchgate.net/)]
- 3. [researchgate.net](https://www.researchgate.net/) [[researchgate.net](https://www.researchgate.net/)]
- 4. [mdpi.com](https://www.mdpi.com/) [[mdpi.com](https://www.mdpi.com/)]
- 5. CK2 in Cancer: Cellular and Biochemical Mechanisms and Potential Therapeutic Target - PMC [[pmc.ncbi.nlm.nih.gov](https://pubmed.ncbi.nlm.nih.gov/)]
- To cite this document: BenchChem. [The Impact of CK2-IN-8 on Cellular Signaling: A Technical Guide]. BenchChem, [2026]. [Online PDF]. Available at: [<https://www.benchchem.com/product/b10812363/docs#the-impact-of-ck2-in-8-on-cellular-signaling-a-technical-guide>]

### Disclaimer & Data Validity:

The information provided in this document is for Research Use Only (RUO) and is strictly not intended for diagnostic or therapeutic procedures. While BenchChem strives to provide

accurate protocols, we make no warranties, express or implied, regarding the fitness of this product for every specific experimental setup.

**Technical Support:** The protocols provided are for reference purposes. Unsure if this reagent suits your experiment?

**Need Industrial/Bulk Grade?** [Request Custom Synthesis Quote](#)

## BenchChem

Our mission is to be the trusted global source of essential and advanced chemicals, empowering scientists and researchers to drive progress in science and industry.

### Contact

Address: 3281 E Guasti Rd

Ontario, CA 91761, United States

Phone: (601) 213-4426

Email: [info@benchchem.com](mailto:info@benchchem.com)

[Contact our Ph.D. Support Team for a compatibility check](#)