

# Technical Support Center: ZINC69391 and Cell Migration Assays

**Author:** BenchChem Technical Support Team. **Date:** April 2026

## Compound of Interest

Compound Name: ZINC69391

Cat. No.: B10811055

[Get Quote](#)

This technical support guide provides troubleshooting advice and answers to frequently asked questions for researchers observing a lack of inhibitory effect from **ZINC69391** in cell migration assays.

## Troubleshooting Guide: Why is ZINC69391 Not Inhibiting Cell Migration?

**ZINC69391** is a specific inhibitor of Rac1, a key protein in the regulation of cell migration.<sup>[1][2]</sup> It functions by preventing the interaction between Rac1 and its activating proteins, known as Guanine nucleotide exchange factors (GEFs).<sup>[1][3][4]</sup> Published studies have demonstrated its ability to inhibit cell migration in various cancer cell lines, including breast cancer and glioma.<sup>[3][5][6]</sup> If you are not observing the expected inhibitory effect, please review the following potential issues.

### Q1: Could the issue be with the compound itself?

**Possible Cause: Compound Concentration** Your concentration of **ZINC69391** may be too low to elicit an inhibitory response in your specific cell line. Different cell lines exhibit varying sensitivities.

Solution:

- Perform a dose-response curve: Test a range of concentrations to determine the optimal inhibitory concentration for your cell line. Studies have successfully used concentrations of 10  $\mu$ M and 50  $\mu$ M to inhibit migration in breast cancer cells.[3]
- Verify IC50 values: The half-maximal inhibitory concentration (IC50) for **ZINC69391**'s antiproliferative effects has been reported in the range of 41 to 54  $\mu$ M in several hematopoietic cell lines.[1][2] While migration inhibition may occur at lower concentrations, this provides a useful reference range.

Possible Cause: Compound Solubility and Stability The compound may not be fully dissolved or could have degraded.

Solution:

- Check solubility: Ensure **ZINC69391** is completely dissolved in the appropriate solvent (e.g., DMSO) before diluting it in your culture medium.[2]
- Proper storage: Stock solutions should be stored correctly. For instance, at -80°C for long-term storage (up to 6 months) or -20°C for shorter periods (1 month).[2] Avoid repeated freeze-thaw cycles.[7]
- Fresh preparation: Prepare fresh working solutions for each experiment from a properly stored stock.

## Q2: Are my cells or culture conditions affecting the outcome?

Possible Cause: Cell Line Specificity The Rac1 pathway, which **ZINC69391** inhibits, may not be the primary driver of migration in your chosen cell line.[1]

Solution:

- Validate the pathway: Confirm that your cells express Rac1 and that its activity is crucial for their migration. You can do this through literature review or by using a positive control inhibitor known to work on the Rac1 pathway.

- Consider alternative pathways: Cell migration is complex and can be driven by various signaling pathways.[8] For example, the closely related GTPase Cdc42 can also regulate migration, and its role can be cell-type dependent.[3][9]

**Possible Cause: Cell Health and Density** The health and density of your cells can significantly impact migration assay results.

**Solution:**

- **Optimal seeding density:** Seeding too few or too many cells can lead to inaccurate results. [10] Determine the optimal cell density for your specific assay through titration experiments.
- **Cell harvesting:** Be gentle during cell harvesting. Over-trypsinization can damage surface receptors necessary for migration.[10]
- **Confluency:** For wound healing (scratch) assays, ensure the cell monolayer is 100% confluent before you create the wound.[7]

### Q3: Is my assay protocol optimized?

**Possible Cause: Confounding Effects of Cell Proliferation (Wound Healing Assay)** If your assay runs for an extended period (e.g., 16-24 hours), the "healing" of the wound could be due to cell proliferation rather than migration.

**Solution:**

- **Use low-serum or serum-free media:** This minimizes proliferative signals.[7]
- **Use a proliferation inhibitor:** Add a mitotic inhibitor like Mitomycin C to your media to halt cell division.

**Possible Cause: Suboptimal Assay Conditions (Transwell Assay)** The transwell assay is sensitive to several parameters that must be optimized.

**Solution:**

- **Correct pore size:** The membrane pores must be large enough for cells to squeeze through but not so large that they fall through. An 8  $\mu\text{m}$  pore size is common for many cancer cell

lines.[7][10]

- Chemoattractant gradient: Ensure a proper chemoattractant gradient is established. Often, this involves serum-starving the cells for 12-24 hours before the assay and placing a chemoattractant (like 10% FBS) in the lower chamber.[10][11]
- Incubation time: The optimal incubation time varies by cell type. Perform a time-course experiment to find the ideal duration.[7]
- Controls: Always include positive and negative controls. A negative control could be a well with no chemoattractant, while a positive control could be a known migration-inducing agent. [10]

## Summary of ZINC69391 Efficacy Data

Cell Line	Assay Type	Concentration	Observed Effect	Citation
MDA-MB-231 (Breast Cancer)	Wound Healing	50 $\mu$ M	100% inhibition of wound closure	[3]
MDA-MB-231 (Breast Cancer)	Wound Healing	10 $\mu$ M	~40% inhibition of wound closure	[3]
F3II (Breast Cancer)	Wound Healing	50 $\mu$ M	80% inhibition of wound closure	[3]
F3II (Breast Cancer)	Wound Healing	10 $\mu$ M	50% inhibition of wound closure	[3]
Human Glioma Cells	Proliferation	0-125 $\mu$ M	Dose-dependent reduction in cell proliferation	[2][6]
U937, HL-60, KG1A, Jurkat	Growth Inhibition	41-54 $\mu$ M (IC50)	Inhibition of cell growth	[1]

## Experimental Protocols

### Protocol: Wound Healing (Scratch) Assay

This protocol provides a standard methodology for assessing cell migration.

- **Cell Seeding:** Seed cells in a 24-well plate at a density that will form a 100% confluent monolayer within 24 hours.
- **Monolayer Formation:** Incubate the cells at 37°C and 5% CO<sub>2</sub> until they are fully confluent.
- **Serum Starvation (Optional):** To minimize proliferation, you may replace the growth medium with serum-free or low-serum (0.5-1%) medium and incubate for 12-24 hours.<sup>[7]</sup>
- **Creating the Wound:** Using a sterile p200 pipette tip or a dedicated scratching tool, make a straight scratch across the center of the cell monolayer.<sup>[7]</sup>
- **Washing:** Gently wash the well twice with serum-free medium or PBS to remove dislodged cells and debris. This is a critical step for a clear wound area.<sup>[7]</sup>
- **Treatment:** Add medium containing the desired concentrations of **ZINC69391** (e.g., 10 μM, 50 μM) and appropriate vehicle controls (e.g., DMSO). If not using serum-free media, consider adding a proliferation inhibitor like Mitomycin C.
- **Image Acquisition (Time 0):** Immediately after adding the treatment, acquire images of the wounds using a microscope at 4x or 10x magnification. Mark reference points to ensure you image the same field at later time points.
- **Incubation:** Incubate the plate at 37°C and 5% CO<sub>2</sub> for a predetermined period (e.g., 12, 18, or 24 hours).
- **Image Acquisition (Time X):** Acquire images of the same wound fields at your chosen time point(s).
- **Data Analysis:** Measure the area of the wound at Time 0 and Time X using software like ImageJ. Calculate the percentage of wound closure for each condition.

## Visualizations

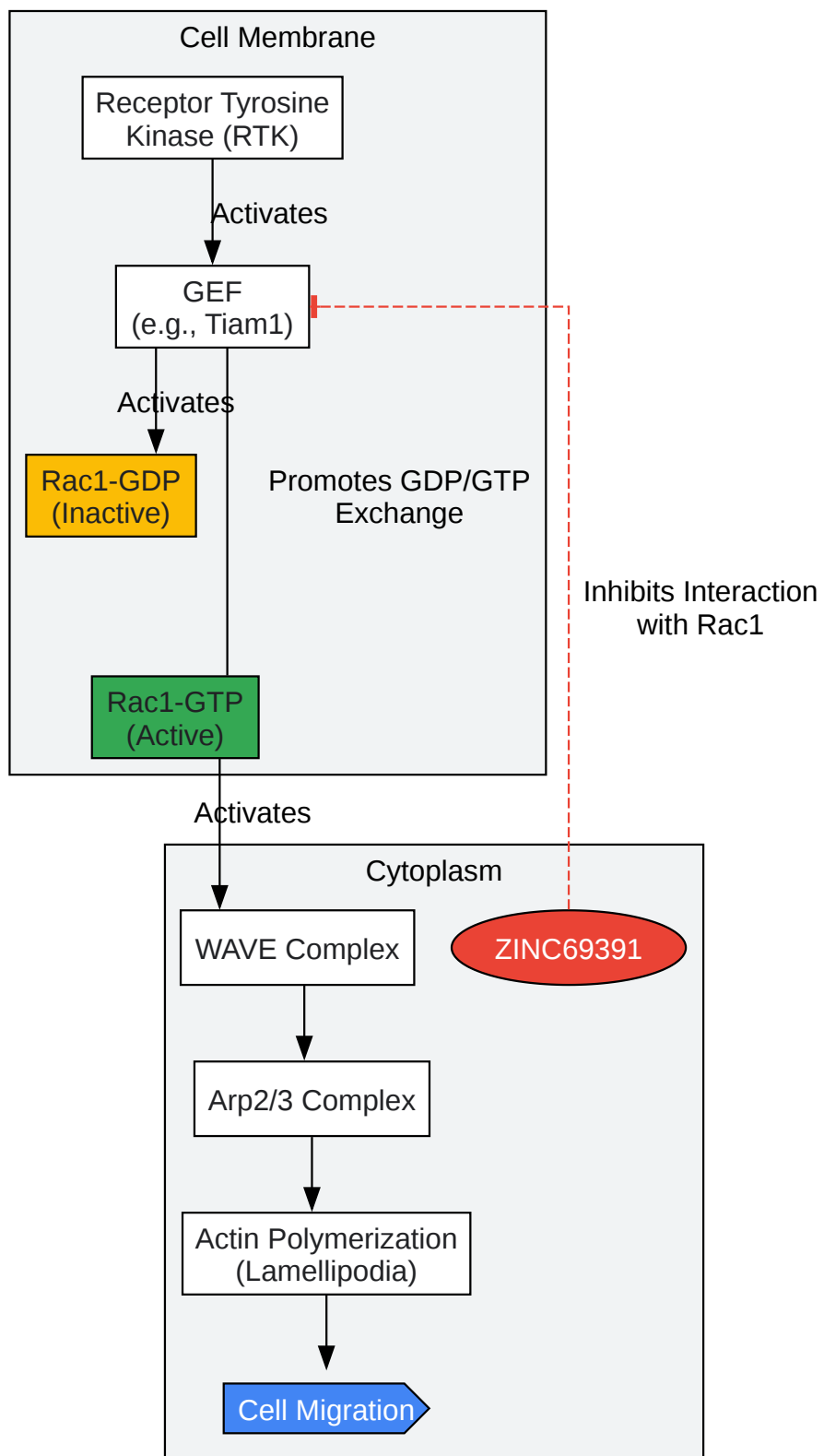

[Click to download full resolution via product page](#)

Caption: The Rac1 signaling pathway, a key driver of cell migration.

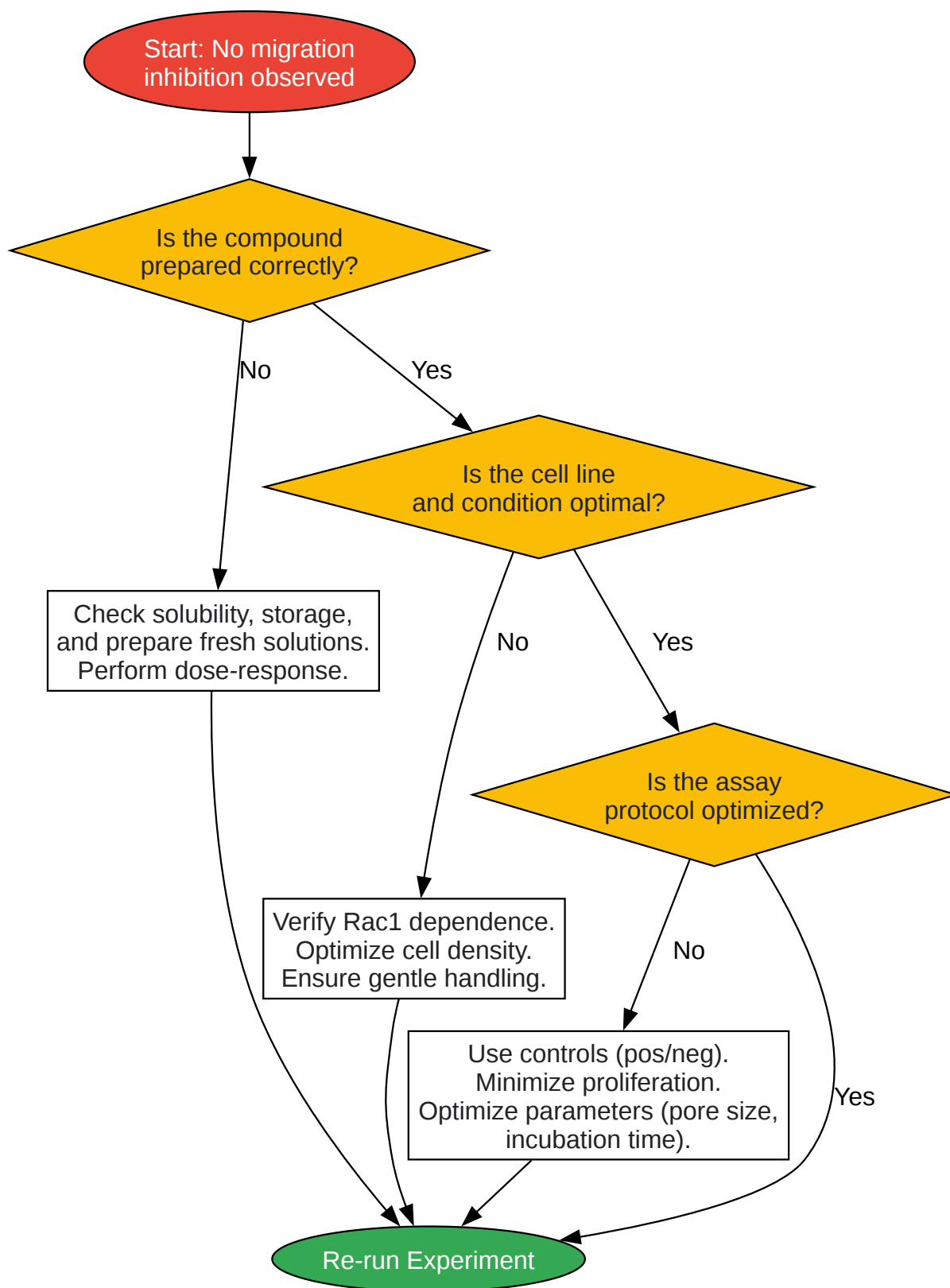

[Click to download full resolution via product page](#)

Caption: Troubleshooting workflow for a failed cell migration inhibition assay.

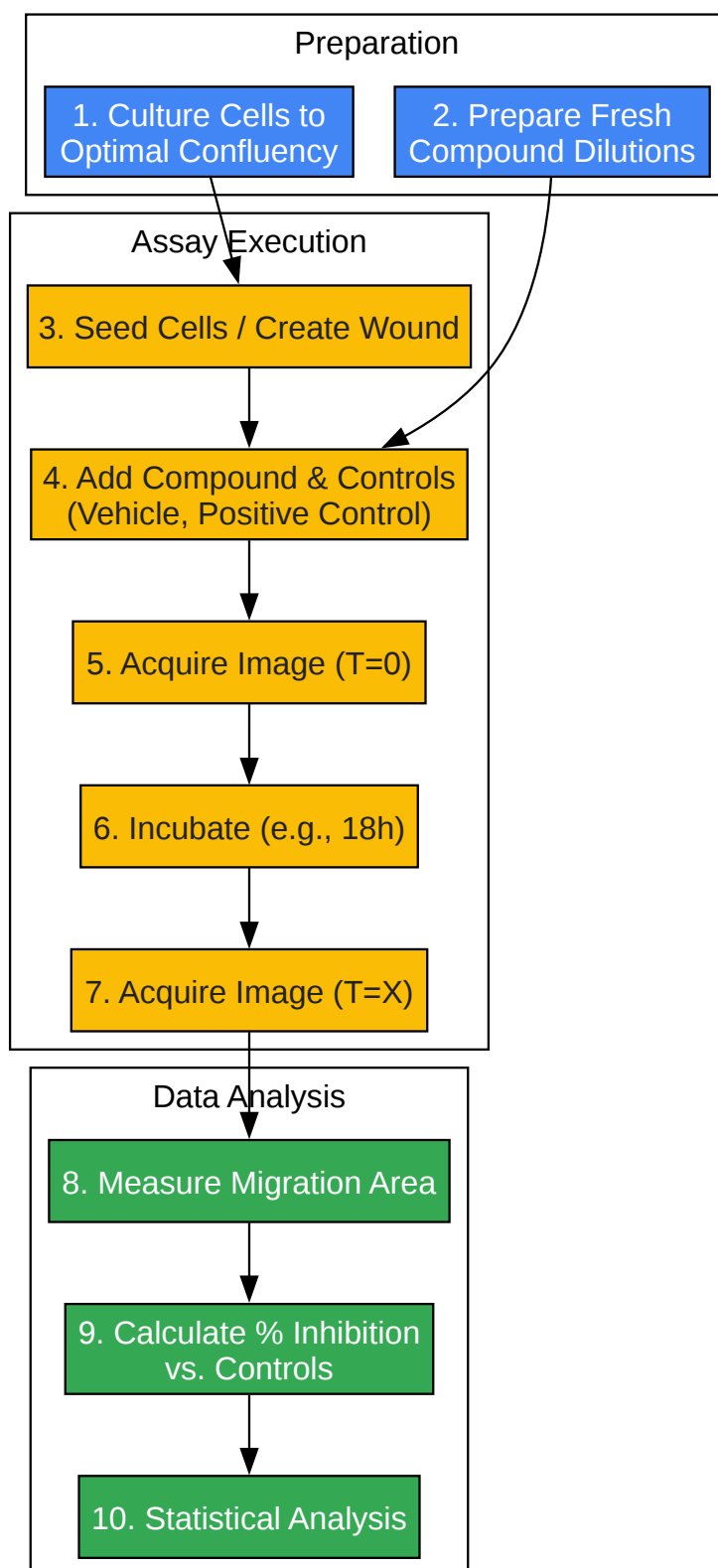

[Click to download full resolution via product page](#)

Caption: Experimental workflow for validating a migration inhibitor.

## Frequently Asked Questions (FAQs)

Q: How do I differentiate between cell migration and cell invasion? A: Cell migration is the movement of cells on a 2D surface or through a porous membrane. Cell invasion is a specific type of migration that requires cells to degrade and move through an extracellular matrix (ECM) barrier. Invasion assays, like the Transwell assay, are modified by coating the membrane with a layer of Matrigel® or a similar ECM component.[12]

Q: My negative control (no chemoattractant) shows high background migration. What should I do? A: High background migration can be caused by several factors. Ensure your cells were properly serum-starved before the assay, as residual serum in the medium can act as a chemoattractant.[7] Also, consider reducing the cell seeding density or shortening the incubation time.[7][10]

Q: What are common positive controls for a cell migration assay? A: A common positive control is to use a high concentration of a known chemoattractant, such as Fetal Bovine Serum (FBS, typically 10-20%) or a specific growth factor like Epidermal Growth Factor (EGF), which is known to activate the Rac1 pathway.[3][11]

Q: Can the solvent for my compound (e.g., DMSO) affect cell migration? A: Yes, at high concentrations, solvents like DMSO can be toxic to cells or have independent effects on cell motility. It is crucial to include a vehicle control in your experiment, which consists of cells treated with the same final concentration of the solvent used to dissolve your inhibitor. This ensures that any observed effects are due to the compound itself and not the solvent.

### Need Custom Synthesis?

BenchChem offers custom synthesis for rare earth carbides and specific isotopic labeling.

Email: [info@benchchem.com](mailto:info@benchchem.com) or [Request Quote Online](#).

## References

- 1. [cancer-research-network.com](https://cancer-research-network.com) [[cancer-research-network.com](https://cancer-research-network.com)]
- 2. [medchemexpress.com](https://medchemexpress.com) [[medchemexpress.com](https://medchemexpress.com)]

- 3. Preclinical Development of Novel Rac1-GEF Signaling Inhibitors using a Rational Design Approach in Highly Aggressive Breast Cancer Cell Lines - PMC [[pmc.ncbi.nlm.nih.gov](https://pubmed.ncbi.nlm.nih.gov)]
- 4. [researchgate.net](https://researchgate.net) [[researchgate.net](https://researchgate.net)]
- 5. [researchgate.net](https://researchgate.net) [[researchgate.net](https://researchgate.net)]
- 6. [researchgate.net](https://researchgate.net) [[researchgate.net](https://researchgate.net)]
- 7. [benchchem.com](https://benchchem.com) [[benchchem.com](https://benchchem.com)]
- 8. Unravelling cell migration: defining movement from the cell surface - PMC [[pmc.ncbi.nlm.nih.gov](https://pubmed.ncbi.nlm.nih.gov)]
- 9. Cdc42 negatively regulates intrinsic migration of highly aggressive breast cancer cells - PubMed [[pubmed.ncbi.nlm.nih.gov](https://pubmed.ncbi.nlm.nih.gov)]
- 10. [corning.com](https://corning.com) [[corning.com](https://corning.com)]
- 11. [researchgate.net](https://researchgate.net) [[researchgate.net](https://researchgate.net)]
- 12. Frontiers | In vitro Cell Migration, Invasion, and Adhesion Assays: From Cell Imaging to Data Analysis [[frontiersin.org](https://frontiersin.org)]
- To cite this document: BenchChem. [Technical Support Center: ZINC69391 and Cell Migration Assays]. BenchChem, [2026]. [Online PDF]. Available at: [<https://www.benchchem.com/product/b10811055/docs#technical-support-center-zinc69391-and-cell-migration-assays>]

---

### Disclaimer & Data Validity:

The information provided in this document is for Research Use Only (RUO) and is strictly not intended for diagnostic or therapeutic procedures. While BenchChem strives to provide accurate protocols, we make no warranties, express or implied, regarding the fitness of this product for every specific experimental setup.

**Technical Support:** The protocols provided are for reference purposes. Unsure if this reagent suits your experiment?

**Need Industrial/Bulk Grade?** [Request Custom Synthesis Quote](#)

# BenchChem

Our mission is to be the trusted global source of essential and advanced chemicals, empowering scientists and researchers to drive progress in science and industry.

## Contact

Address: 3281 E Guasti Rd

Ontario, CA 91761, United States

Phone: (601) 213-4426

Email: [info@benchchem.com](mailto:info@benchchem.com)

[Contact our Ph.D. Support Team for a compatibility check](#)