

In-depth Technical Guide: In Vitro Characterization of a TrkA Inhibitor

Author: BenchChem Technical Support Team. **Date:** April 2026

Compound of Interest

Compound Name: *TrkA-IN-7*
Cat. No.: *B10811634*

[Get Quote](#)

To the Researcher: This guide provides a comprehensive overview of the in vitro characterization of a selective Tropomyosin receptor kinase A (TrkA) inhibitor. The following sections detail the methodologies for key experiments, present quantitative data in a structured format, and include visualizations of critical pathways and workflows.

Important Note on "**TrkA-IN-7**": Initial searches for a specific inhibitor designated "**TrkA-IN-7**" did not yield any publicly available data. This name may correspond to an internal compound code, a novel molecule not yet disclosed in scientific literature, or a potential typographical error. Therefore, this guide has been developed as a template, referencing data and protocols for a representative, well-characterized selective TrkA inhibitor, GVK-TrkI, to illustrate the required in vitro characterization workflow. The principles and methods described herein are broadly applicable to the evaluation of any novel TrkA inhibitor.

Biochemical Characterization

The initial in vitro assessment of a TrkA inhibitor focuses on its direct interaction with the target kinase and its enzymatic activity.

Kinase Inhibition Assay

Objective: To determine the potency of the inhibitor against TrkA kinase activity.

Data Summary:

Compound	Assay Type	Target	IC50 (nM)	ATP Concentration
GVK-TrkI	Z-Lyte Kinase Assay	TrkA	12.5	100 μ M - 1 mM

Experimental Protocol: Z-Lyte™ Kinase Assay for TrkA

This protocol is adapted from established methods for assessing kinase activity.

Materials:

- Recombinant human TrkA enzyme
- Z-Lyte™ Kinase Assay Kit - Tyr 6 Peptide (or a suitable substrate)
- ATP
- Test inhibitor (e.g., GVK-TrkI) dissolved in DMSO
- Assay buffer (e.g., 50 mM HEPES, pH 7.5, 10 mM MgCl₂, 1 mM EGTA, 0.01% Brij-35)
- Stop solution
- Microplate reader capable of fluorescence polarization detection

Procedure:

- **Compound Preparation:** Prepare a serial dilution of the test inhibitor in DMSO. Further dilute in assay buffer to the desired final concentrations.
- **Reaction Mixture Preparation:** In a suitable microplate, add the TrkA enzyme, the fluorescently labeled peptide substrate, and the test inhibitor at various concentrations.

- **Initiation of Reaction:** Initiate the kinase reaction by adding ATP. The final reaction volume is typically 20-25 μ L.
- **Incubation:** Incubate the reaction mixture at room temperature for a specified time (e.g., 60 minutes), allowing the kinase to phosphorylate the substrate.
- **Termination of Reaction:** Stop the reaction by adding the stop solution provided in the assay kit. This solution contains a protease that digests the unphosphorylated substrate.
- **Detection:** Read the fluorescence polarization on a microplate reader. The degree of phosphorylation is proportional to the fluorescence polarization signal.
- **Data Analysis:** Calculate the percent inhibition for each inhibitor concentration relative to a no-inhibitor control. Determine the IC₅₀ value by fitting the data to a four-parameter logistic dose-response curve.

Mechanism of Action: The observation that the IC₅₀ of GVK-TrkI did not significantly change at varying ATP concentrations suggests a non-ATP competitive mode of inhibition.[1]

Workflow Diagram:

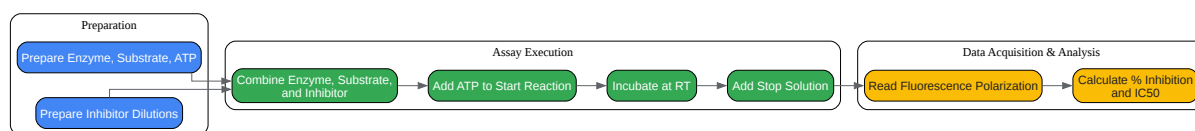

[Click to download full resolution via product page](#)

Workflow for the TrkA Z-Lyte Kinase Assay.

Cellular Characterization

Cell-based assays are crucial for determining an inhibitor's activity in a more physiologically relevant context, assessing its ability to cross cell membranes and inhibit the target in the cellular environment.

Cellular Target Engagement and Pathway Inhibition

Objective: To measure the inhibitor's ability to block TrkA autophosphorylation and inhibit cell proliferation in TrkA-dependent cancer cell lines.

Data Summary:

Compound	Cell Line	Assay Type	Endpoint	IC50/GI50 (nM)
GVK-TrkI	AD293 (expressing WT TrkA)	Cellular Assay	TrkA Inhibition	0.8
GVK-TrkI	KM12 (TPM3-NTRK1 fusion)	Cellular Assay	TrkA Inhibition	1.5
GVK-TrkI	KM12 (TPM3-NTRK1 fusion)	Cell Proliferation	Growth Inhibition	34
GVK-TrkI	Ba/F3 (MPRIP-NTRK1 fusion)	Cell Proliferation	Growth Inhibition	Comparable to KM12

Experimental Protocol: Cellular TrkA Autophosphorylation Assay

This protocol outlines a method to assess the inhibition of ligand-induced or fusion-driven TrkA phosphorylation.

Materials:

- KM12 or other suitable TrkA-driven cell line
- Cell culture medium and supplements
- Test inhibitor (e.g., GVK-TrkI)

- Lysis buffer (e.g., RIPA buffer with protease and phosphatase inhibitors)
- Antibodies: anti-phospho-TrkA (Tyr490), anti-total-TrkA
- Secondary antibodies (HRP-conjugated)
- Western blot equipment and reagents

Procedure:

- Cell Culture and Treatment: Plate cells and allow them to adhere. Treat the cells with a serial dilution of the inhibitor for a specified time (e.g., 2-24 hours).
- Cell Lysis: Wash the cells with cold PBS and lyse them on ice with lysis buffer.
- Protein Quantification: Determine the protein concentration of the lysates using a standard method (e.g., BCA assay).
- Western Blotting:
 - Separate equal amounts of protein from each sample by SDS-PAGE.
 - Transfer the proteins to a PVDF or nitrocellulose membrane.
 - Block the membrane with a suitable blocking buffer (e.g., 5% BSA or non-fat milk in TBST).
 - Incubate the membrane with the primary antibody against phospho-TrkA overnight at 4°C.
 - Wash the membrane and incubate with an HRP-conjugated secondary antibody.
 - Detect the signal using a chemiluminescence substrate.
 - Strip the membrane and re-probe with an antibody against total TrkA as a loading control.
- Data Analysis: Quantify the band intensities using densitometry. Normalize the phospho-TrkA signal to the total TrkA signal. Calculate the percent inhibition of phosphorylation relative to the vehicle-treated control and determine the IC50 value.

Experimental Protocol: Cell Proliferation Assay

Materials:

- KM12 or other TrkA-dependent cell line
- Cell culture medium
- Test inhibitor
- Cell viability reagent (e.g., CellTiter-Glo®, MTS, or similar)
- 96-well plates
- Plate reader

Procedure:

- **Cell Seeding:** Seed cells in a 96-well plate at a predetermined density.
- **Compound Treatment:** After allowing the cells to attach, treat them with a serial dilution of the inhibitor.
- **Incubation:** Incubate the plates for a period that allows for multiple cell divisions (e.g., 72 hours).
- **Viability Measurement:** Add the cell viability reagent to each well according to the manufacturer's instructions.
- **Detection:** Measure the signal (luminescence, absorbance, etc.) using a plate reader.
- **Data Analysis:** Calculate the percent growth inhibition for each concentration relative to vehicle-treated cells. Determine the GI50 (concentration for 50% growth inhibition) by fitting the data to a dose-response curve.

Signaling Pathway Diagram:

The binding of Nerve Growth Factor (NGF) to TrkA induces receptor dimerization and autophosphorylation, initiating downstream signaling cascades.^[2]^[3] Key pathways include the Ras/MAPK pathway, crucial for cell differentiation and survival, and the PI3K/Akt pathway, which is vital for cell survival and growth.^[3] TrkA inhibitors block the initial autophosphorylation step, thereby inhibiting these downstream signals.

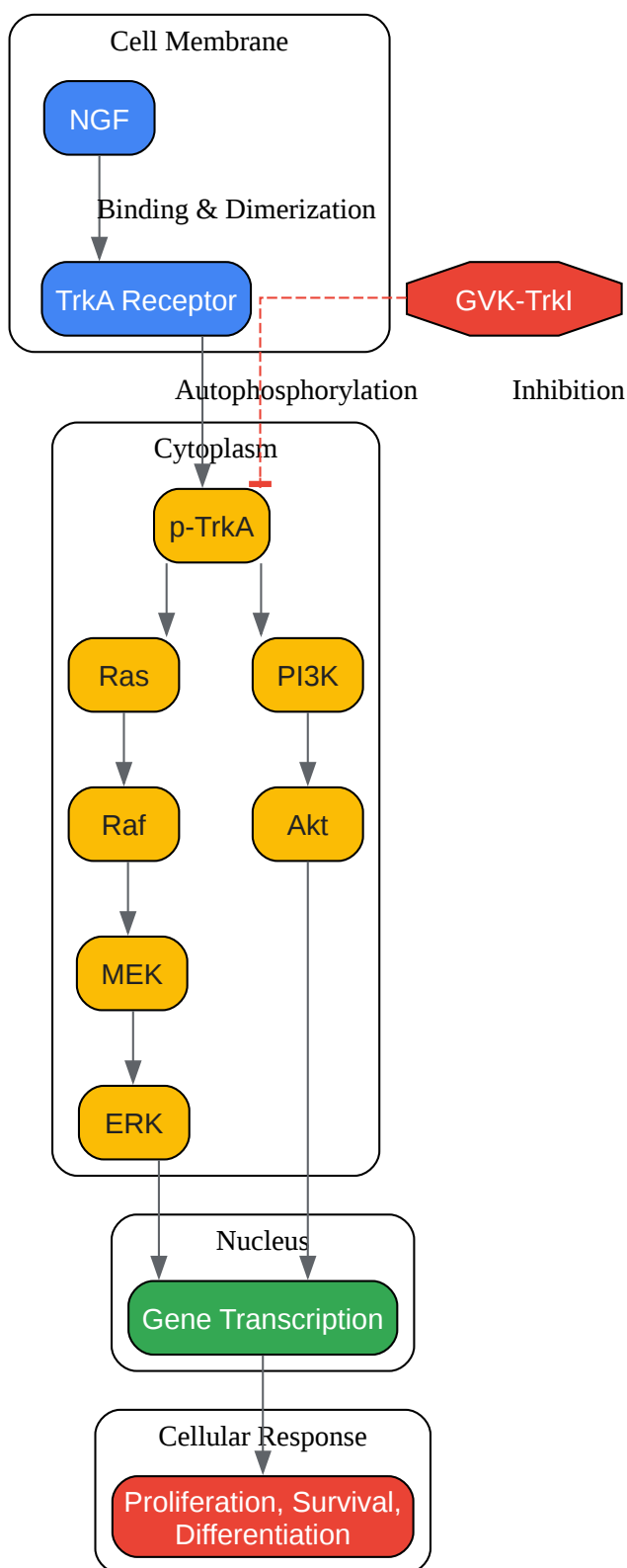

[Click to download full resolution via product page](#)

TrkA signaling pathways and the point of inhibition.

Selectivity Profiling

Assessing the selectivity of an inhibitor is critical to understanding its potential for off-target effects.

Kinase Selectivity Panel

Objective: To determine the inhibitor's activity against a broad panel of kinases to assess its selectivity for TrkA.

Data Summary:

Compound	Target	Selectivity vs. TrkB	Selectivity vs. TrkC
GVK-Trkl	TrkA	>1000-fold	>1000-fold

Experimental Protocol: Kinase Selectivity Profiling

Procedure:

- The test inhibitor is screened at a fixed concentration (e.g., 1 μ M) against a large panel of purified kinases (e.g., the DiscoverX KINOMEscan™ panel or similar services).
- The activity of each kinase is measured in the presence of the inhibitor, and the percent inhibition is calculated.
- For kinases showing significant inhibition, full IC50 curves are generated to determine the potency of the inhibitor against these off-targets.
- The selectivity is expressed as the ratio of the IC50 for the off-target kinase to the IC50 for the primary target (TrkA).

Logical Diagram for Selectivity Assessment:

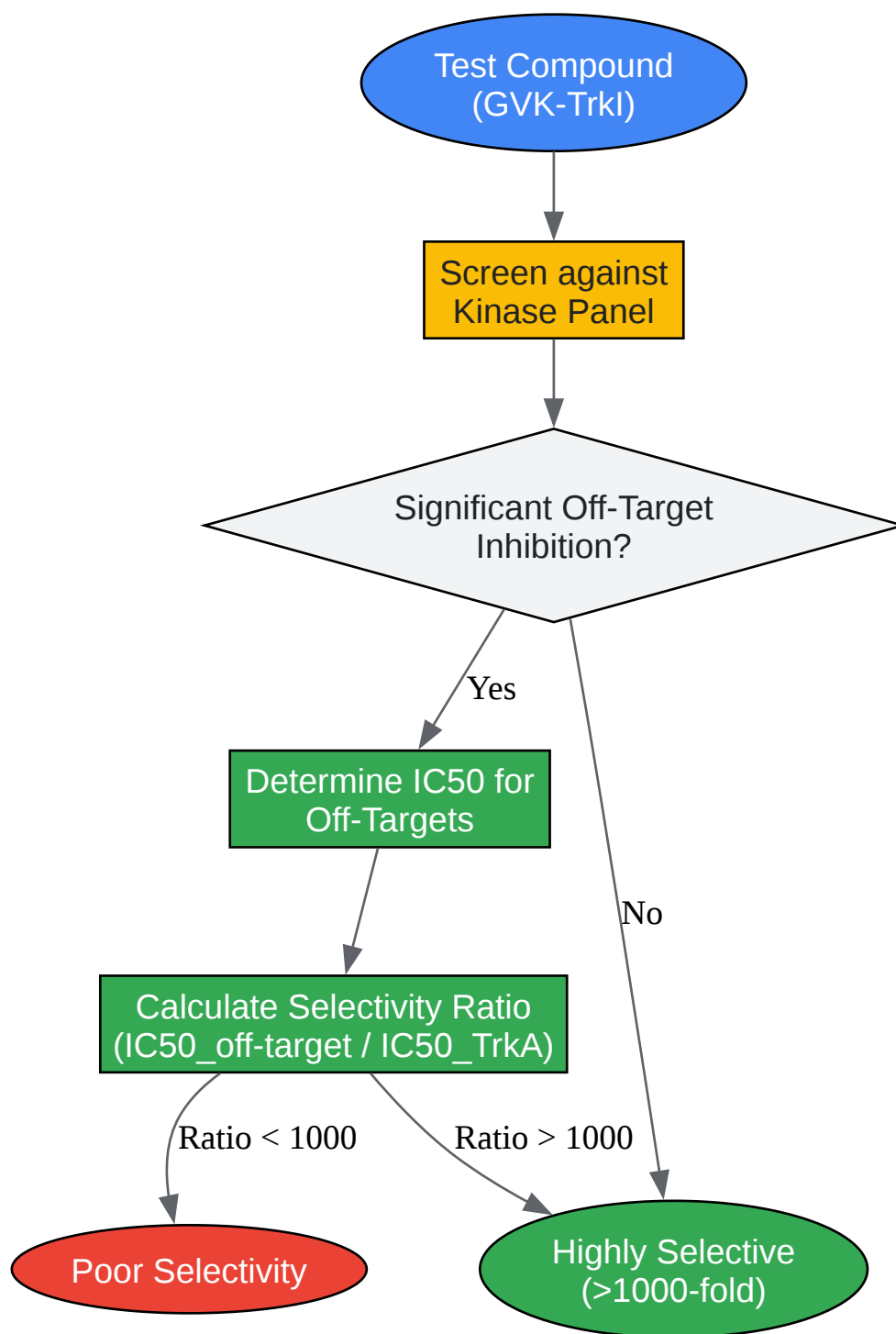

[Click to download full resolution via product page](#)

Decision workflow for kinase selectivity profiling.

Need Custom Synthesis?

BenchChem offers custom synthesis for rare earth carbides and specific isotopic labeling.

Email: info@benchchem.com or [Request Quote Online](#).

References

- [1. aacrjournals.org \[aacrjournals.org\]](https://aacrjournals.org)
- [2. Discovery of novel TrkA allosteric inhibitors: Structure-based virtual screening, biological evaluation and preliminary SAR studies - PubMed \[pubmed.ncbi.nlm.nih.gov\]](#)
- [3. Structural characterization of nonactive site, TrkA-selective kinase inhibitors \(Journal Article\) | OSTI.GOV \[osti.gov\]](#)
- To cite this document: BenchChem. [In-depth Technical Guide: In Vitro Characterization of a TrkA Inhibitor]. BenchChem, [2026]. [Online PDF]. Available at: [\[https://www.benchchem.com/product/b10811634/docs#in-depth-technical-guide-in-vitro-characterization-of-a-trka-inhibitor\]](https://www.benchchem.com/product/b10811634/docs#in-depth-technical-guide-in-vitro-characterization-of-a-trka-inhibitor)

Disclaimer & Data Validity:

The information provided in this document is for Research Use Only (RUO) and is strictly not intended for diagnostic or therapeutic procedures. While BenchChem strives to provide accurate protocols, we make no warranties, express or implied, regarding the fitness of this product for every specific experimental setup.

Technical Support: The protocols provided are for reference purposes. Unsure if this reagent suits your experiment?

Need Industrial/Bulk Grade? [Request Custom Synthesis Quote](#)

BenchChem

Our mission is to be the trusted global source of essential and advanced chemicals, empowering scientists and researchers to drive progress in science and industry.

Contact

Address: 3281 E Guasti Rd

Ontario, CA 91761, United States

Phone: (601) 213-4426

Email: info@benchchem.com

[Contact our Ph.D. Support Team for a compatibility check](#)