

# The Discovery and Development of ROS-IN-1: A Technical Overview

**Author:** BenchChem Technical Support Team. **Date:** April 2026

## Compound of Interest

Compound Name: ROS-IN-1  
Cat. No.: B10803233

[Get Quote](#)

For Researchers, Scientists, and Drug Development Professionals

## Introduction

**ROS-IN-1** is a recently identified small molecule inhibitor of mitochondrial reactive oxygen species (ROS). It has garnered attention within the research community for its potential in modulating cellular metabolism and mitigating oxidative stress. This technical guide provides a comprehensive overview of the discovery, development, mechanism of action, and experimental protocols associated with **ROS-IN-1**, also referred to in patent literature as Compound 40.

## Discovery and Development

**ROS-IN-1** was first disclosed in a patent by Martin D. and colleagues, titled "Compounds and methods for modulating mitochondrial metabolism and reactive oxygen species production"[1]. The invention describes a series of compounds, including **ROS-IN-1** (Compound 40), designed to inhibit the production of mitochondrial ROS. While the full developmental history is contained within the patent, commercial availability of **ROS-IN-1** from various suppliers indicates its utility as a research tool for studying the roles of mitochondrial ROS in cellular physiology and pathology.

The chemical structure of **ROS-IN-1** is defined by the SMILES string CC1=CC(C)=C(C(C)=C1)S(=O)(=O)N1CCCC1=O, corresponding to the chemical name N-(2,4,5-trimethylphenyl)sulfonyl-2-pyrrolidinone.

## Mechanism of Action

**ROS-IN-1** functions as a mitochondrial ROS inhibitor. Mitochondria, the primary sites of cellular respiration, are also a major source of endogenous ROS. Specifically, the electron transport chain (ETC) can leak electrons, which then react with molecular oxygen to form superoxide radicals ( $O_2^{\cdot-}$ ), a primary ROS. This process is particularly prominent at Complex I and Complex III of the ETC. An overproduction of mitochondrial ROS can lead to oxidative stress, damaging cellular components such as DNA, lipids, and proteins, and has been implicated in a wide range of diseases.

While the precise molecular target of **ROS-IN-1** within the mitochondria has not been fully elucidated in publicly available literature, its described function is to reduce the overall output of mitochondrial ROS. One vendor reports that **ROS-IN-1** (Compound 40) can reduce ROS production by 25.1%<sup>[1]</sup>. The specific conditions and assay used to determine this value are detailed in the originating patent. Inhibitors of mitochondrial ROS can act through various mechanisms, including direct scavenging of ROS, inhibition of ROS-producing enzymes within the ETC, or by modulating mitochondrial metabolism to reduce electron leakage.

## Quantitative Data

The publicly available quantitative data for **ROS-IN-1** is currently limited. The primary reported value is a 25.1% reduction in ROS production<sup>[1]</sup>. For more detailed quantitative data, such as IC50 or Ki values for mitochondrial ROS inhibition, researchers are directed to the primary patent literature.

Table 1: Quantitative Data for **ROS-IN-1**

| Parameter                   | Value | Source         |
|-----------------------------|-------|----------------|
| Reduction in ROS Production | 25.1% | <sup>[1]</sup> |

## Signaling Pathways

Mitochondrial ROS are integral components of cellular signaling, and their modulation by inhibitors like **ROS-IN-1** can impact various pathways. Key signaling cascades influenced by cellular redox state include:

- **NF- $\kappa$ B** (Nuclear Factor kappa-light-chain-enhancer of activated B cells) Signaling: ROS can act as second messengers in the NF- $\kappa$ B pathway, which is a critical regulator of inflammation, immunity, and cell survival.
- **Nrf2** (Nuclear factor erythroid 2-related factor 2) Signaling: This pathway is the master regulator of the antioxidant response. Under conditions of oxidative stress, Nrf2 translocates to the nucleus and activates the expression of numerous antioxidant and cytoprotective genes.
- **PI3K/Akt** (Phosphoinositide 3-kinase/Protein Kinase B) Signaling: This pathway is central to cell growth, proliferation, and survival. ROS can modulate PI3K/Akt signaling at multiple levels, influencing cell fate.

The following diagrams illustrate the general interplay between mitochondrial ROS and these key signaling pathways.

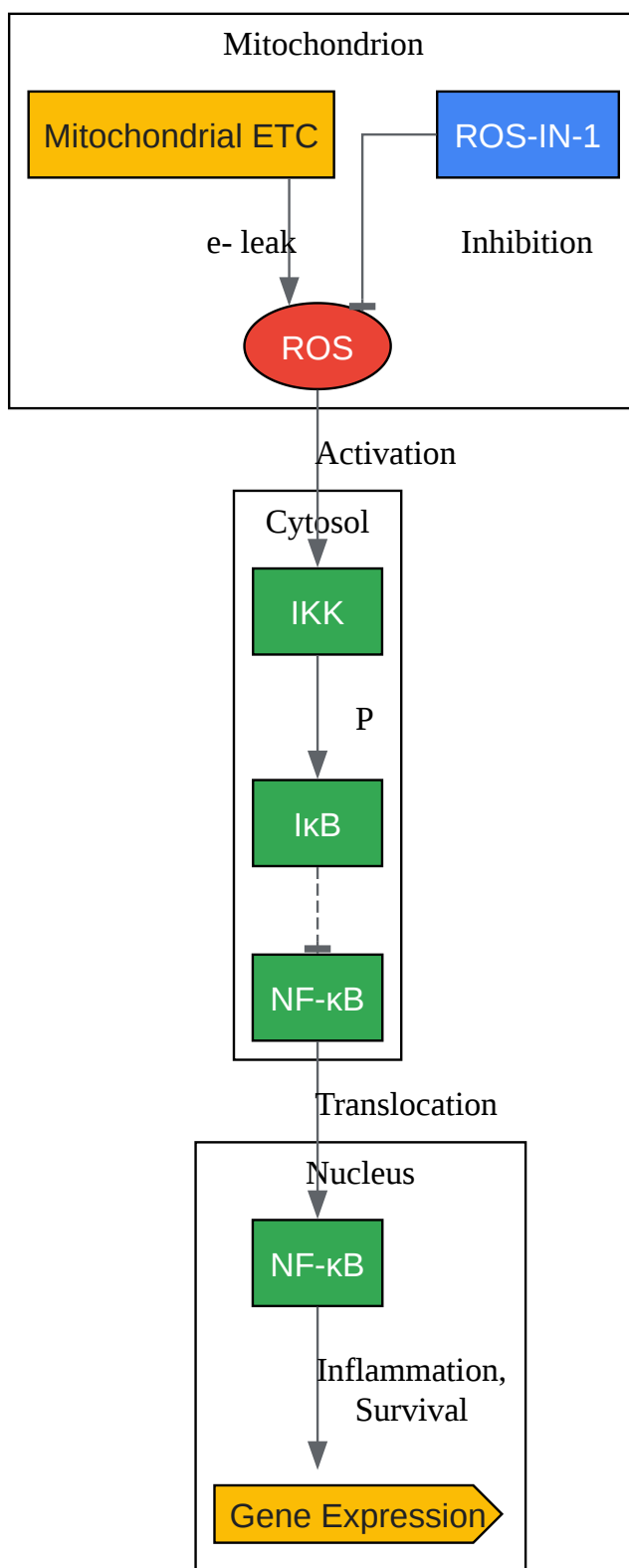

[Click to download full resolution via product page](#)

Caption: **ROS-IN-1** inhibits mitochondrial ROS, which can activate the NF-κB signaling pathway.

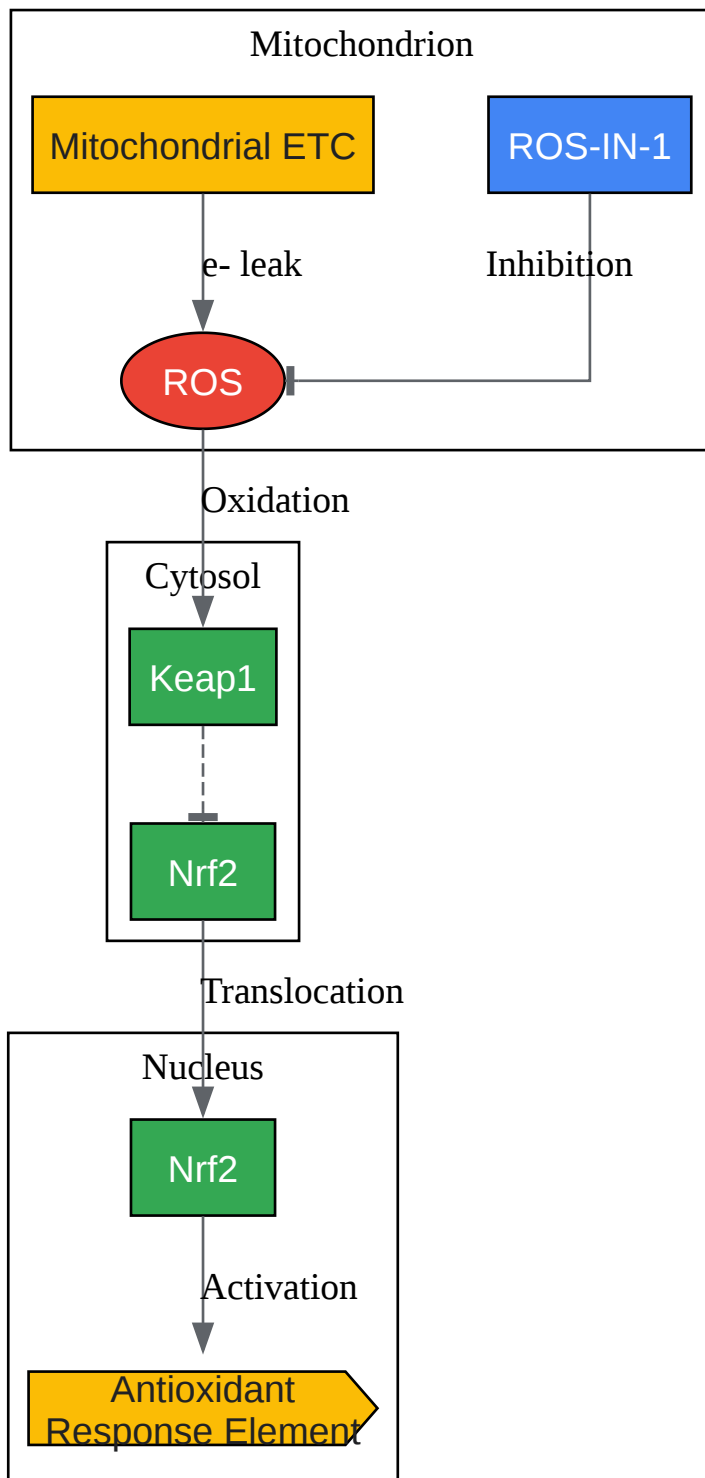

[Click to download full resolution via product page](#)

Caption: **ROS-IN-1**'s inhibition of ROS can modulate the Nrf2 antioxidant response pathway.

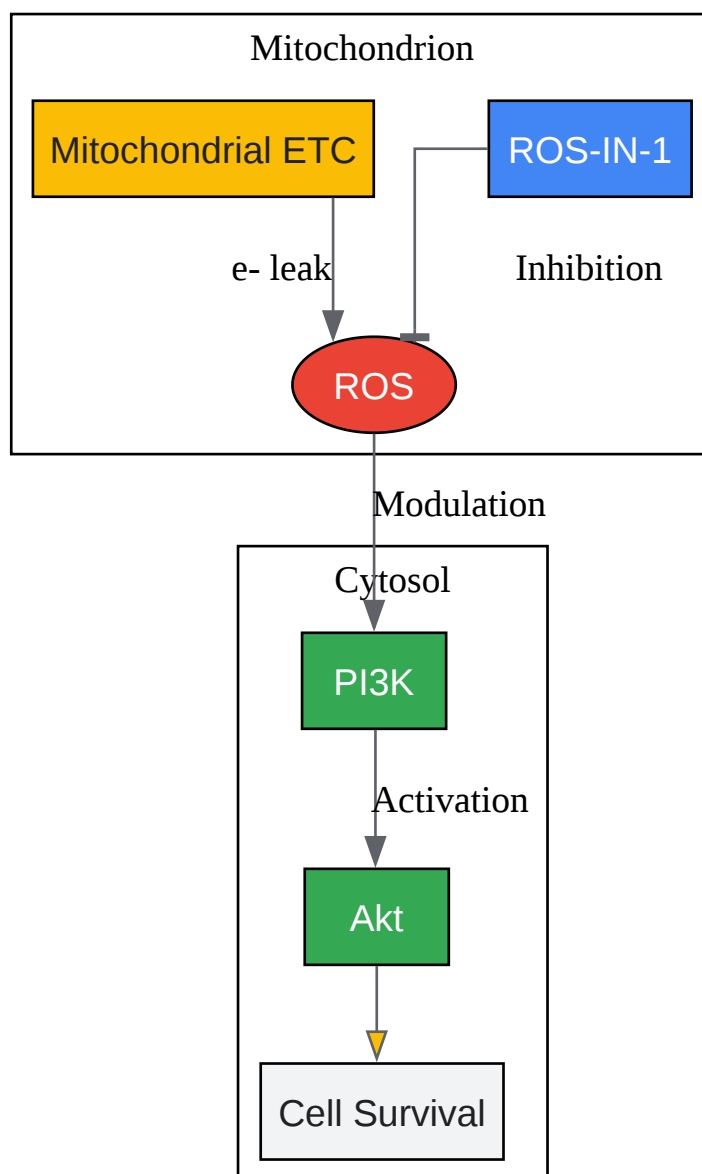

[Click to download full resolution via product page](#)

Caption: Mitochondrial ROS, inhibited by **ROS-IN-1**, can modulate the PI3K/Akt signaling pathway.

## Experimental Protocols

The following are detailed methodologies for key experiments relevant to the characterization of mitochondrial ROS inhibitors like **ROS-IN-1**.

## MitoSOX Red Assay for Mitochondrial Superoxide Detection

This assay is used to specifically detect superoxide in the mitochondria of live cells.

Materials:

- MitoSOX Red reagent
- Dimethyl sulfoxide (DMSO)
- Hanks' Balanced Salt Solution (HBSS) or other suitable buffer
- Cell culture medium
- Black, clear-bottom 96-well plates
- Fluorescence microscope or plate reader

Procedure:

- **Cell Seeding:** Seed cells in a black, clear-bottom 96-well plate at a density that will result in 70-80% confluency on the day of the experiment. Allow cells to adhere overnight.
- **Preparation of MitoSOX Red Working Solution:** Prepare a stock solution of MitoSOX Red in DMSO. Immediately before use, dilute the stock solution in pre-warmed HBSS or cell culture medium to the desired final concentration (typically 1-5  $\mu\text{M}$ ).
- **Cell Treatment:** Remove the culture medium from the cells and wash once with pre-warmed HBSS. Add the **ROS-IN-1** or vehicle control at the desired concentrations to the cells in fresh culture medium and incubate for the desired time.
- **Staining:** Remove the treatment medium and add the MitoSOX Red working solution to each well. Incubate the plate at 37°C for 10-30 minutes, protected from light.
- **Washing:** Remove the MitoSOX Red working solution and wash the cells three times with pre-warmed HBSS.

- Measurement: Add pre-warmed HBSS to each well. Measure the fluorescence using a fluorescence microscope (Excitation/Emission: ~510/580 nm) or a fluorescence plate reader.

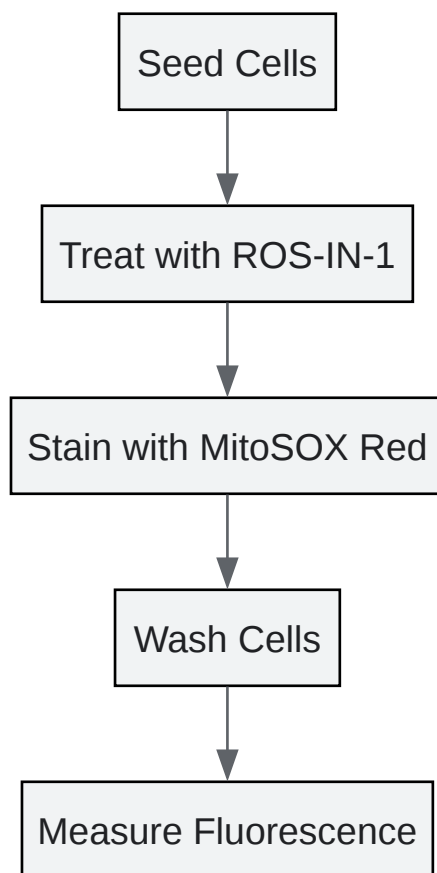

[Click to download full resolution via product page](#)

Caption: Workflow for the MitoSOX Red assay to measure mitochondrial superoxide.

## Amplex Red Assay for Hydrogen Peroxide Detection

This assay is used to detect the release of hydrogen peroxide ( $H_2O_2$ ) from cells or isolated mitochondria.

Materials:

- Amplex Red reagent
- Horseradish peroxidase (HRP)
- DMSO

- Reaction buffer (e.g., Krebs-Ringer-phosphate-glucose buffer)
- 96-well black microplate
- Fluorescence plate reader

Procedure:

- Preparation of Amplex Red/HRP Working Solution: Prepare a stock solution of Amplex Red in DMSO. On the day of the experiment, prepare a working solution containing Amplex Red (e.g., 50  $\mu$ M) and HRP (e.g., 0.1 U/mL) in the reaction buffer. Protect the solution from light.
- Cell/Mitochondria Preparation: Prepare a suspension of cells or isolated mitochondria in the reaction buffer.
- Assay Initiation: In a 96-well black microplate, add the cell/mitochondrial suspension. Add **ROS-IN-1** or vehicle control. To initiate the reaction, add the Amplex Red/HRP working solution.
- Incubation: Incubate the plate at 37°C for a specified time (e.g., 30-60 minutes), protected from light.
- Measurement: Measure the fluorescence using a fluorescence plate reader (Excitation/Emission: ~530-560/590 nm).

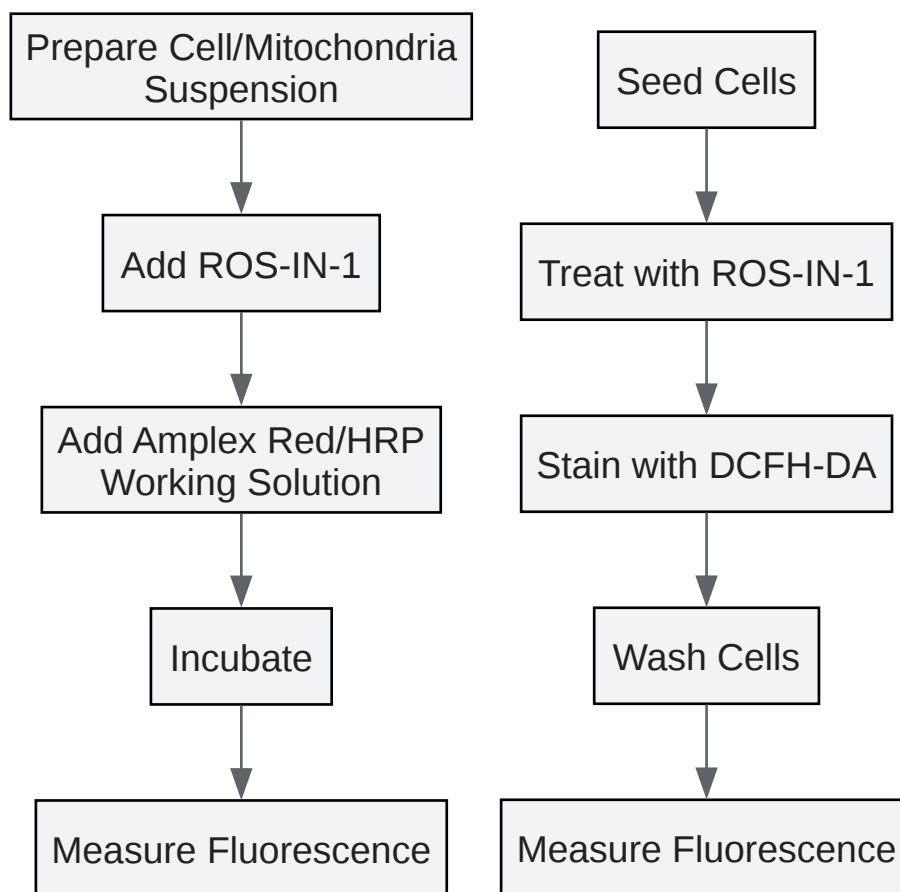

[Click to download full resolution via product page](#)

### Need Custom Synthesis?

BenchChem offers custom synthesis for rare earth carbides and specific isotopic labeling.

Email: [info@benchchem.com](mailto:info@benchchem.com) or [Request Quote Online](#).

## References

- 1. [medchemexpress.com](https://www.medchemexpress.com) [[medchemexpress.com](https://www.medchemexpress.com)]
- To cite this document: BenchChem. [The Discovery and Development of ROS-IN-1: A Technical Overview]. BenchChem, [2026]. [Online PDF]. Available at: [<https://www.benchchem.com/product/b10803233/docs#the-discovery-and-development-of-ros-in-1-a-technical-overview>]

### Disclaimer & Data Validity:

The information provided in this document is for Research Use Only (RUO) and is strictly not intended for diagnostic or therapeutic procedures. While BenchChem strives to provide accurate protocols, we make no warranties, express or implied, regarding the fitness of this product for every specific experimental setup.

**Technical Support:** The protocols provided are for reference purposes. Unsure if this reagent suits your experiment?

**Need Industrial/Bulk Grade?** [Request Custom Synthesis Quote](#)

## BenchChem

Our mission is to be the trusted global source of essential and advanced chemicals, empowering scientists and researchers to drive progress in science and industry.

### Contact

Address: 3281 E Guasti Rd  
Ontario, CA 91761, United States  
Phone: (601) 213-4426  
Email: [info@benchchem.com](mailto:info@benchchem.com)

[Contact our Ph.D. Support Team for a compatibility check](#)