

# Technical Support Center: Troubleshooting Inconsistent Results in Fak-IN-10 Experiments

**Author:** BenchChem Technical Support Team. **Date:** April 2026

## Compound of Interest

Compound Name: *Fak-IN-10*  
Cat. No.: *B10803282*

[Get Quote](#)

Welcome to the technical support center for **Fak-IN-10**, a potent and selective inhibitor of Focal Adhesion Kinase (FAK). This resource is designed to assist researchers, scientists, and drug development professionals in troubleshooting and ensuring the consistency and reliability of their experimental results.

## Frequently Asked Questions (FAQs)

Q1: What is **Fak-IN-10** and what is its mechanism of action?

A1: **Fak-IN-10** is a small molecule inhibitor that targets the kinase activity of Focal Adhesion Kinase (FAK). FAK is a non-receptor tyrosine kinase that plays a crucial role in signal transduction pathways downstream of integrins and growth factor receptors, regulating key cellular processes such as cell adhesion, migration, proliferation, and survival.<sup>[1][2][3][4]</sup> **Fak-IN-10** is an ATP-competitive inhibitor, binding to the ATP-binding pocket of the FAK kinase domain, thereby preventing the phosphorylation of FAK at tyrosine 397 (Y397) and subsequent downstream signaling.<sup>[5][6]</sup>

Q2: What are the common applications of **Fak-IN-10** in research?

A2: **Fak-IN-10** is widely used in cancer research to study the role of FAK in tumor progression, metastasis, and angiogenesis.[7][8] It is also utilized in studies related to fibrosis, inflammation, and other diseases where FAK signaling is dysregulated. Common experimental applications include cell migration and invasion assays, proliferation assays, apoptosis assays, and in vivo tumor models.

Q3: I am observing high variability in my cell viability assay results with **Fak-IN-10**. What could be the cause?

A3: High variability in cell viability assays can stem from several factors. These include inconsistencies in cell seeding density, variations in the passage number of the cell line, instability of the **Fak-IN-10** compound in your culture medium, or the presence of resistant cell populations. Refer to the troubleshooting guide below for a systematic approach to identify and resolve the issue.

Q4: My Western blot results for phospho-FAK (Y397) are inconsistent after **Fak-IN-10** treatment. What should I check?

A4: Inconsistent phospho-FAK (p-FAK) levels can be due to variations in treatment time, incomplete cell lysis, phosphatase activity during sample preparation, or issues with antibody quality. Ensure that your lysis buffer contains adequate phosphatase inhibitors and that you are using a validated antibody for p-FAK (Y397).

## Troubleshooting Guides

### Issue 1: Inconsistent Inhibition of Cell Migration/Invasion

Symptoms:

- High standard deviation between replicate wells in a transwell migration or invasion assay.
- Lack of a clear dose-dependent inhibition of migration/invasion.
- Results vary significantly between experiments performed on different days.

Possible Causes and Solutions:

Possible Cause	Recommended Solution
Cell Health and Confluency	Ensure cells are healthy and in the logarithmic growth phase. Avoid using cells that are over-confluent or have been in culture for too many passages.
Serum Concentration in Media	The presence of growth factors in serum can compete with the inhibitory effect of Fak-IN-10. Consider reducing the serum concentration in the upper chamber of the transwell or using serum-free media.
Inconsistent Seeding Density	Use a hemocytometer or an automated cell counter to ensure a consistent number of cells are seeded in each well.
Fak-IN-10 Stability	Prepare fresh dilutions of Fak-IN-10 from a stock solution for each experiment. Avoid repeated freeze-thaw cycles of the stock solution.
Assay Incubation Time	Optimize the incubation time for your specific cell line. A time-course experiment can help determine the optimal endpoint.

## Issue 2: Variable Results in Western Blotting for FAK Pathway Proteins

### Symptoms:

- Inconsistent levels of phospho-FAK (Y397), phospho-Src (Y416), phospho-paxillin, or phospho-ERK between biological replicates.
- High background or non-specific bands on the Western blot.

### Possible Causes and Solutions:

Possible Cause	Recommended Solution
Suboptimal Lysis Buffer	Use a lysis buffer containing fresh phosphatase and protease inhibitors to prevent dephosphorylation and degradation of target proteins.
Inconsistent Protein Quantification	Use a reliable protein quantification method (e.g., BCA assay) to ensure equal loading of protein in each lane.
Antibody Quality	Use antibodies that have been validated for the specific application (Western blotting) and species. Titrate the antibody to determine the optimal concentration.
Transfer Efficiency	Verify the efficiency of protein transfer from the gel to the membrane using a Ponceau S stain.
Washing Steps	Ensure adequate washing of the membrane to reduce background signal.

## Experimental Protocols

### Protocol 1: Western Blot Analysis of FAK Phosphorylation

- **Cell Treatment:** Plate cells at a density of  $1 \times 10^6$  cells per 60 mm dish. Allow cells to adhere overnight. Treat cells with the desired concentrations of **Fak-IN-10** or vehicle control (e.g., DMSO) for the specified duration (e.g., 2 hours).
- **Cell Lysis:** Wash cells twice with ice-cold PBS. Lyse the cells on ice with 200  $\mu$ L of RIPA buffer supplemented with protease and phosphatase inhibitor cocktails.
- **Protein Quantification:** Determine the protein concentration of each lysate using a BCA protein assay kit.
- **SDS-PAGE and Transfer:** Load 20-30  $\mu$ g of protein per lane onto a 4-20% Tris-glycine gel. Following electrophoresis, transfer the proteins to a PVDF membrane.

- Immunoblotting: Block the membrane with 5% non-fat dry milk or BSA in TBST for 1 hour at room temperature. Incubate the membrane with a primary antibody against phospho-FAK (Y397) overnight at 4°C. Wash the membrane three times with TBST. Incubate with an appropriate HRP-conjugated secondary antibody for 1 hour at room temperature. Wash three times with TBST.
- Detection: Visualize the protein bands using an enhanced chemiluminescence (ECL) detection system.

## Protocol 2: Transwell Migration Assay

- Cell Preparation: Culture cells to 70-80% confluency. Starve the cells in serum-free medium for 12-24 hours.
- Assay Setup: Pre-coat the transwell inserts (8 µm pore size) with an appropriate extracellular matrix protein (e.g., fibronectin, 10 µg/mL) and allow to dry.
- Cell Seeding: Resuspend the starved cells in serum-free medium containing different concentrations of **Fak-IN-10** or vehicle control. Seed  $1 \times 10^5$  cells into the upper chamber of the transwell inserts.
- Chemoattractant: Add medium containing a chemoattractant (e.g., 10% FBS) to the lower chamber.
- Incubation: Incubate the plate at 37°C in a 5% CO<sub>2</sub> incubator for a predetermined time (e.g., 6-24 hours).
- Cell Staining and Counting: Remove the non-migrated cells from the upper surface of the insert with a cotton swab. Fix the migrated cells on the lower surface with 4% paraformaldehyde and stain with 0.1% crystal violet.
- Quantification: Count the number of migrated cells in several random fields under a microscope.

## Data Presentation

Table 1: Representative IC<sub>50</sub> Values of **Fak-IN-10** in Various Cancer Cell Lines

Cell Line	Cancer Type	IC50 (nM) for FAK (Y397) Phosphorylation Inhibition	IC50 (nM) for Cell Viability (72h)
MDA-MB-231	Breast Cancer	15	250
U87 MG	Glioblastoma	25	400
AsPC-1	Pancreatic Cancer	10	150
HCT116	Colon Cancer	30	500

Note: These are representative values and may vary depending on experimental conditions.

## Visualizations

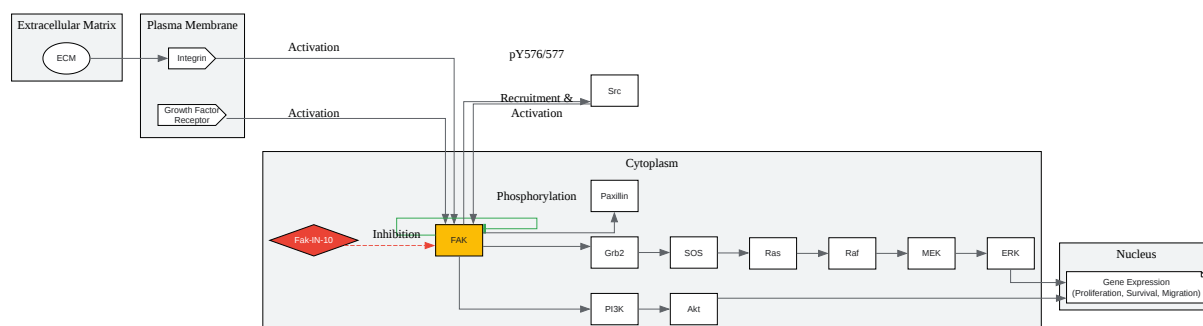

[Click to download full resolution via product page](#)

Caption: FAK signaling pathway and the inhibitory action of **Fak-IN-10**.

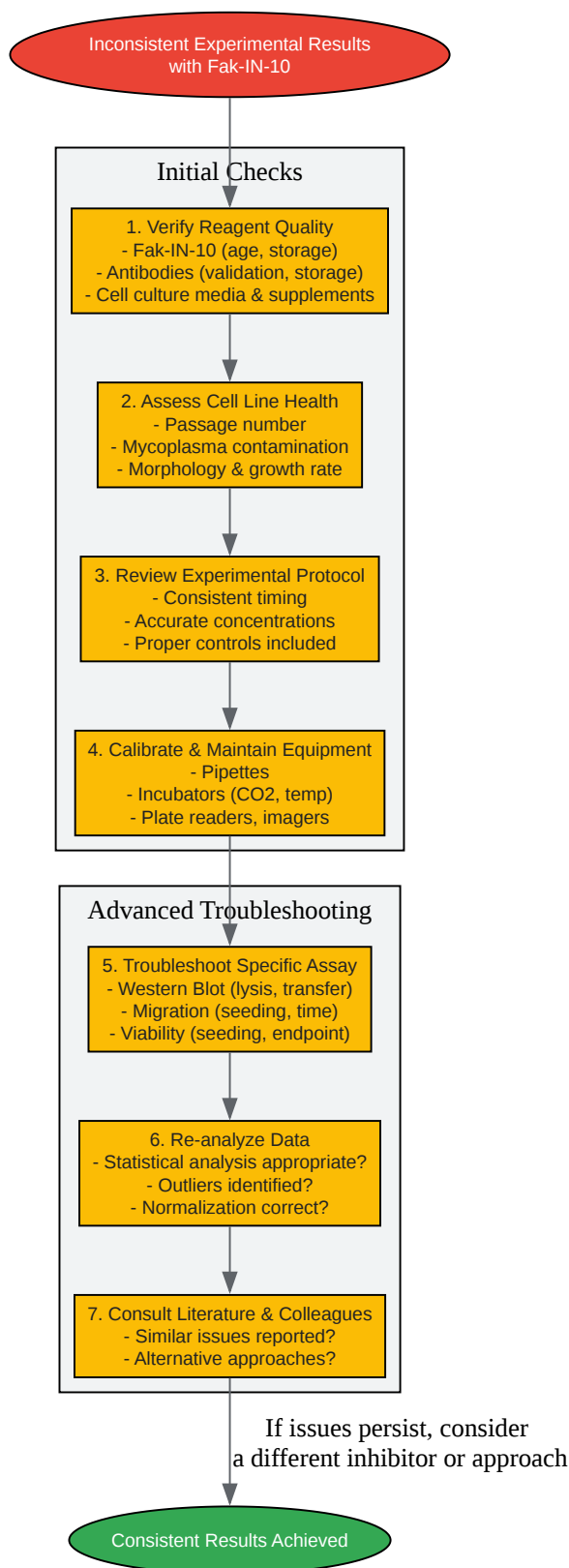

[Click to download full resolution via product page](#)

Caption: A logical workflow for troubleshooting inconsistent **Fak-IN-10** experimental results.

### Need Custom Synthesis?

BenchChem offers custom synthesis for rare earth carbides and specific isotopic labeling.

Email: [info@benchchem.com](mailto:info@benchchem.com) or [Request Quote Online](#).

## References

- [1. Focal adhesion kinase and its signaling pathways in cell migration and angiogenesis - PMC \[pmc.ncbi.nlm.nih.gov\]](#)
- [2. aacrjournals.org \[aacrjournals.org\]](#)
- [3. FAK-Src Signaling Pathway: Tyrosine Kinases in Cell Migration & Cancer Progression - Creative Biolabs \[creativebiolabs.net\]](#)
- [4. Focal adhesion kinase and its signaling pathways in cell migration and angiogenesis - PubMed \[pubmed.ncbi.nlm.nih.gov\]](#)
- [5. encyclopedia.pub \[encyclopedia.pub\]](#)
- [6. Highly Selective Focal Adhesion Kinase \(FAK\) Inhibitors - Innovations \[innovations.dana-farber.org\]](#)
- [7. Understanding the Roles of FAK in Cancer: Inhibitors, Genetic Models, and New Insights - PMC \[pmc.ncbi.nlm.nih.gov\]](#)
- [8. FAK in cancer: mechanistic findings and clinical applications - PMC \[pmc.ncbi.nlm.nih.gov\]](#)
- To cite this document: BenchChem. [Technical Support Center: Troubleshooting Inconsistent Results in Fak-IN-10 Experiments]. BenchChem, [2026]. [Online PDF]. Available at: [\[https://www.benchchem.com/product/b10803282/docs#technical-support-center-troubleshooting-inconsistent-results-in-fak-in-10-experiments\]](https://www.benchchem.com/product/b10803282/docs#technical-support-center-troubleshooting-inconsistent-results-in-fak-in-10-experiments)

---

### Disclaimer & Data Validity:

The information provided in this document is for Research Use Only (RUO) and is strictly not intended for diagnostic or therapeutic procedures. While BenchChem strives to provide

accurate protocols, we make no warranties, express or implied, regarding the fitness of this product for every specific experimental setup.

**Technical Support:** The protocols provided are for reference purposes. Unsure if this reagent suits your experiment?

**Need Industrial/Bulk Grade?** [Request Custom Synthesis Quote](#)

## BenchChem

Our mission is to be the trusted global source of essential and advanced chemicals, empowering scientists and researchers to drive progress in science and industry.

### Contact

Address: 3281 E Guasti Rd

Ontario, CA 91761, United States

Phone: (601) 213-4426

Email: [info@benchchem.com](mailto:info@benchchem.com)

[Contact our Ph.D. Support Team for a compatibility check](#)