

Technical Support Center: Ensuring ROS1-IN-1 Stability in Long-Term Experiments

Author: BenchChem Technical Support Team. **Date:** April 2026

Compound of Interest

Compound Name: ROS-IN-1
Cat. No.: B10803233

[Get Quote](#)

This technical support center provides researchers, scientists, and drug development professionals with troubleshooting guides and frequently asked questions (FAQs) to ensure the stability and consistent performance of ROS1-IN-1 in long-term experiments.

Frequently Asked Questions (FAQs)

Q1: What is ROS1-IN-1 and what is its primary mechanism of action?

A1: ROS1-IN-1 is a potent and selective inhibitor of the ROS1 receptor tyrosine kinase.[1] In certain cancers, particularly non-small cell lung cancer (NSCLC), the ROS1 gene can undergo rearrangement, leading to the expression of a fusion protein with constitutive kinase activity. This aberrant signaling drives tumor growth and survival.[2][3] ROS1-IN-1 acts by binding to the ATP-binding pocket of the ROS1 kinase domain, thereby blocking its downstream signaling pathways, which include the JAK/STAT3, PI3K/AKT/mTOR, and RAS/MAPK pathways.[2][4][5]

Q2: How should I prepare and store stock solutions of ROS1-IN-1?

A2: For optimal stability, dissolve ROS1-IN-1 powder in a suitable organic solvent such as dimethyl sulfoxide (DMSO) to prepare a high-concentration stock solution (e.g., 10 mM).[6] Aliquot the stock solution into single-use volumes to avoid repeated freeze-thaw cycles, which

can degrade the compound.[6][7] Store the aliquots at -20°C or -80°C for long-term stability.[6] When preparing working solutions, it is best to make initial serial dilutions in DMSO before the final dilution in your aqueous experimental buffer or cell culture medium to prevent precipitation.

Q3: What is the recommended final concentration of DMSO in my experiments?

A3: It is crucial to keep the final concentration of DMSO in your cell culture or assay buffer as low as possible, typically below 0.5%, to avoid solvent-induced toxicity or off-target effects.[6] Always include a vehicle control (medium with the same final concentration of DMSO) in your experiments to account for any effects of the solvent itself.

Q4: How stable is ROS1-IN-1 in aqueous solutions and cell culture media?

A4: Like many small molecule inhibitors, the stability of ROS1-IN-1 in aqueous solutions can be limited. It is best practice to prepare fresh working solutions from your DMSO stock for each experiment. Avoid storing the inhibitor in aqueous buffers for extended periods. For long-term experiments (e.g., several days), consider replacing the media with freshly prepared ROS1-IN-1-containing media every 24-48 hours to maintain a consistent effective concentration.[7]

Q5: I'm observing a decrease in the inhibitory effect of ROS1-IN-1 over time in my long-term cell culture experiment. What could be the cause?

A5: A decline in efficacy over time can be attributed to several factors:

- **Compound Degradation:** The inhibitor may be degrading in the cell culture medium at 37°C.
- **Cellular Metabolism:** The cells may be metabolizing the compound, reducing its intracellular concentration.[7]
- **Development of Resistance:** Prolonged exposure to a kinase inhibitor can lead to the activation of compensatory signaling pathways or the selection of resistant cell populations.
[7][8]

Troubleshooting Guide

Issue	Potential Cause	Recommended Action
Inconsistent or no inhibitory activity	<p>1. Improper inhibitor preparation or storage: The compound may have degraded due to improper handling. 2. Incorrect inhibitor concentration: The concentration used may be too low for the specific cell line or assay. 3. Cell line authenticity/passage number: High passage numbers can lead to altered cell characteristics and inhibitor sensitivity.</p>	<p>1. Prepare fresh stock solutions from powder. Aliquot and store at -20°C or -80°C. Avoid repeated freeze-thaw cycles. 2. Perform a dose-response experiment to determine the IC50 in your specific system. 3. Use low-passage, authenticated cells.</p>
Decreased efficacy in long-term experiments (>48 hours)	<p>1. Inhibitor instability in media: The compound may be degrading at 37°C. 2. Cellular metabolism of the inhibitor: Cells may be clearing the compound. 3. Emergence of resistant clones: Prolonged treatment can select for resistant cells.</p>	<p>1. Replenish the media with fresh inhibitor every 24-48 hours. 2. Perform a time-course experiment to assess the duration of effective inhibition. 3. Analyze downstream signaling pathways for reactivation. Consider intermittent dosing schedules.</p>
Compound precipitation in aqueous buffer/media	<p>1. Low solubility in aqueous solutions: The inhibitor is precipitating out of solution. 2. High final concentration of the inhibitor: The concentration exceeds its solubility limit in the aqueous medium.</p>	<p>1. Prepare serial dilutions in DMSO first, then add to the aqueous buffer. Ensure the final DMSO concentration is low (<0.5%). 2. Prepare working solutions fresh for each experiment. If precipitation occurs at the desired concentration, consider using a different</p>

formulation or delivery method if possible.

High background signal or off-target effects	1. High DMSO concentration: The solvent may be causing cellular stress or other non-specific effects. 2. Inhibitor concentration is too high: Supramaximal concentrations can lead to off-target kinase inhibition.	1. Ensure the final DMSO concentration is below 0.5%. Always use a vehicle control. 2. Use the lowest effective concentration determined from your dose-response curve.
--	---	---

Experimental Protocols

Protocol 1: Preparation of ROS1-IN-1 Stock and Working Solutions

- **Warm to Room Temperature:** Before opening, allow the vial of ROS1-IN-1 powder to equilibrate to room temperature for at least 20 minutes to prevent condensation.
- **Prepare Stock Solution:** Add the appropriate volume of high-quality, anhydrous DMSO to the vial to achieve a stock concentration of 10 mM. Mix thoroughly by vortexing until the powder is completely dissolved.
- **Aliquot and Store:** Dispense the stock solution into single-use, low-binding microcentrifuge tubes. Store the aliquots at -20°C for short-term storage (up to 1 month) or -80°C for long-term storage (up to 6 months).^[6]
- **Prepare Working Solutions:** On the day of the experiment, thaw a single aliquot of the stock solution. Prepare serial dilutions in DMSO to an intermediate concentration. From the intermediate DMSO dilution, add the required volume to your pre-warmed cell culture medium or assay buffer to achieve the final desired concentration. Mix immediately by gentle inversion.

Protocol 2: Assessing the Stability of ROS1-IN-1 in Cell Culture Medium

- **Prepare Samples:** Prepare a working solution of ROS1-IN-1 in your complete cell culture medium at the desired final concentration (e.g., 1 μ M). Also, prepare a vehicle control (medium with the same concentration of DMSO).
- **Incubation:** Incubate the prepared media in a sterile container under standard cell culture conditions (37°C, 5% CO₂) for different time points (e.g., 0, 8, 24, 48, and 72 hours).
- **Sample Collection:** At each time point, collect an aliquot of the incubated medium and store it at -80°C until analysis.
- **Activity Assay:** Use a cell-free kinase assay to determine the remaining activity of ROS1-IN-1 in the collected samples. This can be done by assessing the inhibition of recombinant ROS1 kinase activity.
- **Data Analysis:** Plot the percentage of remaining ROS1-IN-1 activity against the incubation time to determine its stability profile in the cell culture medium.

Signaling Pathways and Workflows

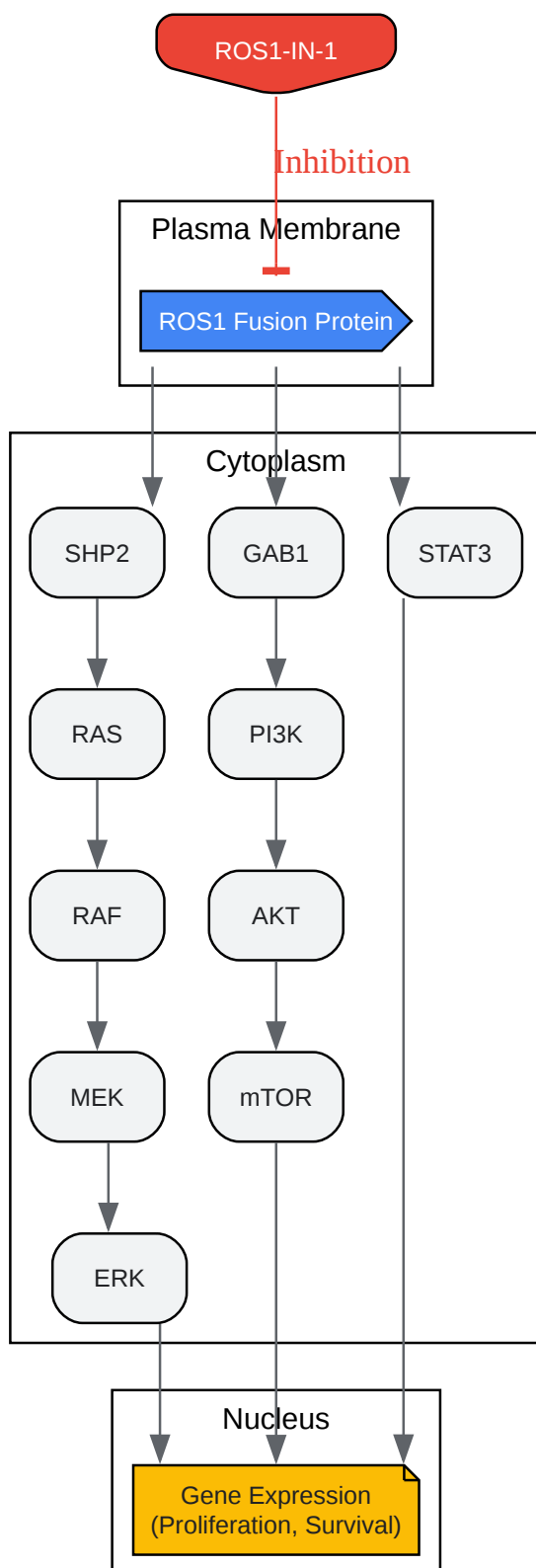

[Click to download full resolution via product page](#)

Caption: Simplified ROS1 signaling pathway and the inhibitory action of ROS1-IN-1.

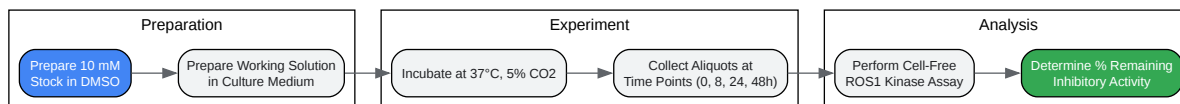

[Click to download full resolution via product page](#)

Caption: Experimental workflow for assessing the stability of ROS1-IN-1 in cell culture medium.

Need Custom Synthesis?

BenchChem offers custom synthesis for rare earth carbides and specific isotopic labeling.

Email: info@benchchem.com or [Request Quote Online](#).

References

- [1. medchemexpress.com \[medchemexpress.com\]](https://www.medchemexpress.com)
- [2. researchgate.net \[researchgate.net\]](https://www.researchgate.net)
- [3. What are ROS1 inhibitors and how do they work? \[synapse.patsnap.com\]](https://www.synapse.patsnap.com)
- [4. creative-diagnostics.com \[creative-diagnostics.com\]](https://www.creative-diagnostics.com)
- [5. Molecular Pathways - ROS1 Fusion Proteins in Cancer - PMC \[pmc.ncbi.nlm.nih.gov\]](https://pubmed.ncbi.nlm.nih.gov)
- [6. medchemexpress.cn \[medchemexpress.cn\]](https://www.medchemexpress.cn)
- [7. benchchem.com \[benchchem.com\]](https://www.benchchem.com)
- [8. Molecular Pathways: Resistance to Kinase Inhibitors and Implications for Therapeutic Strategies - PMC \[pmc.ncbi.nlm.nih.gov\]](https://pubmed.ncbi.nlm.nih.gov)
- To cite this document: BenchChem. [Technical Support Center: Ensuring ROS1-IN-1 Stability in Long-Term Experiments]. BenchChem, [2026]. [Online PDF]. Available at: [\[https://www.benchchem.com/product/b10803233/docs#technical-support-center-ensuring-ros1-in-1-stability-in-long-term-experiments\]](https://www.benchchem.com/product/b10803233/docs#technical-support-center-ensuring-ros1-in-1-stability-in-long-term-experiments)

Disclaimer & Data Validity:

The information provided in this document is for Research Use Only (RUO) and is strictly not intended for diagnostic or therapeutic procedures. While BenchChem strives to provide accurate protocols, we make no warranties, express or implied, regarding the fitness of this product for every specific experimental setup.

Technical Support: The protocols provided are for reference purposes. Unsure if this reagent suits your experiment?

Need Industrial/Bulk Grade? [Request Custom Synthesis Quote](#)

BenchChem

Our mission is to be the trusted global source of essential and advanced chemicals, empowering scientists and researchers to drive progress in science and industry.

Contact

Address: 3281 E Guasti Rd
Ontario, CA 91761, United States
Phone: (601) 213-4426
Email: info@benchchem.com

[Contact our Ph.D. Support Team for a compatibility check](#)