

The Role of (S)-GSK1379725A in Chromatin Remodeling: A Technical Guide

Author: BenchChem Technical Support Team. **Date:** April 2026

Compound of Interest

Compound Name: (S)-GSK1379725A

Cat. No.: B10800846

[Get Quote](#)

For Researchers, Scientists, and Drug Development Professionals

Introduction

(S)-GSK1379725A is a selective small molecule inhibitor of the bromodomain of the Bromodomain and PHD Finger Transcription Factor (BPTF). BPTF is the largest and a crucial scaffolding subunit of the Nucleosome Remodeling Factor (NURF) complex, a key player in chromatin remodeling. The NURF complex utilizes the energy of ATP hydrolysis to modulate nucleosome positioning, thereby influencing gene expression. The bromodomain of BPTF specifically recognizes and binds to acetylated lysine residues on histone tails, particularly histone H4 acetylated at lysine 16 (H4K16ac). This interaction is critical for tethering the NURF complex to specific chromatin regions, facilitating transcriptional activation of target genes. Dysregulation of BPTF and the NURF complex has been implicated in various cancers, making it a compelling target for therapeutic intervention. **(S)-GSK1379725A**, by competitively binding to the acetyl-lysine binding pocket of the BPTF bromodomain, disrupts this crucial interaction, leading to downstream effects on gene expression and cellular processes. This technical guide provides a comprehensive overview of the mechanism of action of **(S)-GSK1379725A**, its quantitative binding affinities, detailed experimental protocols for its characterization, and its impact on cellular signaling pathways.

Data Presentation

Quantitative Binding Affinity and Cellular Activity of (S)-GSK1379725A

Parameter	Value	Assay Method	Target	Notes
Binding Affinity (Kd)	2.8 μ M	Isothermal Titration Calorimetry (ITC)	Human BPTF Bromodomain	(S)-enantiomer of racemic AU1. [1][2]
Binding Affinity (Kd)	2.8 μ M	Protein-observed Fluorine NMR (PrOF NMR)	Human BPTF Bromodomain	Consistent with ITC data.[3]
Cellular Activity	G1 cell cycle arrest	Flow Cytometry	Breast epithelial cells	Inhibition of BPTF by its racemic form, AU1, leads to cell cycle arrest. [1]
Cellular Activity	Decreased c-MYC regulated gene expression	Gene Expression Analysis	Breast epithelial cells	Treatment with the racemic form, AU1, reduces the expression of genes regulated by the oncogene c-MYC.[1]
Cellular Activity	Increased genomic accessibility at distal regulatory regions	ATAC-seq	Mammary tumor cells	Pharmacologic inhibition with S-AU-1 alters chromatin accessibility.[4]

Signaling Pathway

The following diagram illustrates the role of BPTF in chromatin remodeling and the mechanism of inhibition by (S)-GSK1379725A.

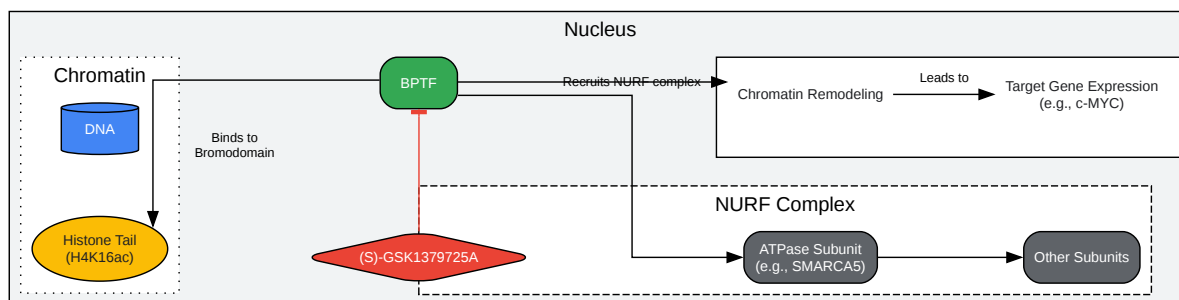

[Click to download full resolution via product page](#)

Caption: BPTF's role in chromatin remodeling and its inhibition by **(S)-GSK1379725A**.

Experimental Workflows and Protocols

The characterization of **(S)-GSK1379725A** involves a series of biophysical and cell-based assays to determine its binding affinity, selectivity, and cellular effects.

Experimental Workflow for BPTF Inhibitor Characterization

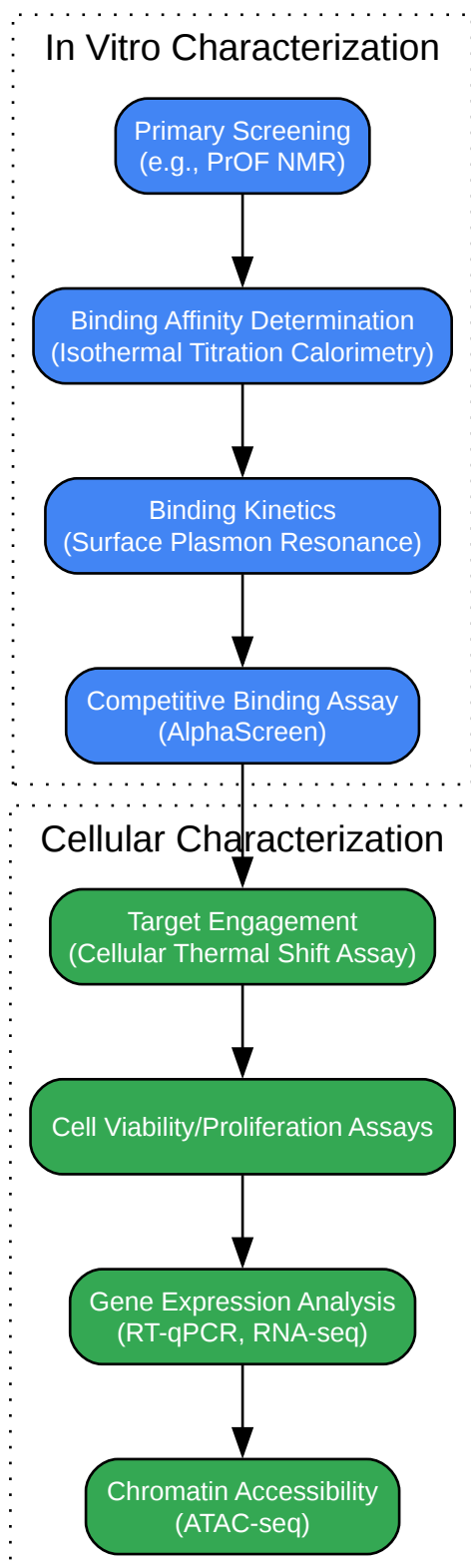

[Click to download full resolution via product page](#)

Caption: Workflow for the discovery and characterization of BPTF inhibitors.

Detailed Methodologies

Isothermal Titration Calorimetry (ITC)

Objective: To determine the binding affinity (K_d), stoichiometry (n), and thermodynamic parameters (ΔH and ΔS) of **(S)-GSK1379725A** binding to the BPTF bromodomain.

Protocol:

- Protein Preparation: Express and purify the human BPTF bromodomain (e.g., residues 2735-2858) with a suitable tag (e.g., His-tag) for purification. Dialyze the purified protein extensively against the ITC buffer (e.g., 50 mM HEPES pH 7.5, 150 mM NaCl).
- Ligand Preparation: Dissolve **(S)-GSK1379725A** in the same ITC buffer. A small amount of DMSO may be used for initial solubilization, ensuring the final concentration in the buffer is matched between the protein and ligand solutions and is typically below 5%.
- ITC Experiment:
 - Load the BPTF bromodomain solution (typically 20-50 μM) into the sample cell of the ITC instrument.
 - Load the **(S)-GSK1379725A** solution (typically 200-500 μM) into the injection syringe.
 - Perform a series of injections (e.g., 19 injections of 2 μL each) of the ligand into the protein solution at a constant temperature (e.g., 25 $^{\circ}\text{C}$).
- Data Analysis: Integrate the heat changes associated with each injection and fit the resulting binding isotherm to a suitable binding model (e.g., one-site binding model) to determine the K_d , n , ΔH , and ΔS .

Protein-observed Fluorine NMR (PrOF NMR)

Objective: To confirm the binding of **(S)-GSK1379725A** to the BPTF bromodomain and estimate the binding affinity. This technique is particularly useful for detecting weak to moderate binders.

Protocol:

- **Protein Preparation:** Prepare a fluorine-labeled BPTF bromodomain. This can be achieved by incorporating a fluorine-containing amino acid analog (e.g., 5-fluoro-tryptophan) during protein expression. Purify and dialyze the labeled protein into an NMR buffer (e.g., 50 mM TRIS, 100 mM NaCl, pH 7.4, with 10% D₂O).
- **NMR Titration:**
 - Acquire a 1D ¹⁹F NMR spectrum of the fluorine-labeled BPTF bromodomain (typically at 25-50 μM).
 - Perform a stepwise titration by adding increasing concentrations of **(S)-GSK1379725A** to the protein sample.
 - Acquire a ¹⁹F NMR spectrum after each addition.
- **Data Analysis:** Monitor the chemical shift perturbations of the fluorine resonance upon ligand binding. The change in chemical shift ($\Delta\delta$) is plotted against the ligand concentration and fitted to a binding equation to calculate the K_d.

AlphaScreen (Amplified Luminescent Proximity Homogeneous Assay)

Objective: To measure the ability of **(S)-GSK1379725A** to competitively inhibit the interaction between the BPTF bromodomain and an acetylated histone peptide.

Protocol:

- **Reagents:**
 - His-tagged BPTF bromodomain.
 - Biotinylated histone H4 peptide acetylated at lysines 5, 8, 12, and 16.
 - Streptavidin-coated Donor beads.
 - Nickel chelate-coated Acceptor beads.
 - Assay buffer (e.g., 50 mM HEPES, 100 mM NaCl, 0.1% BSA, 0.05% CHAPS, pH 7.4).

- Assay Procedure:
 - In a 384-well plate, add the His-tagged BPTF bromodomain (final concentration ~30 nM) and the biotinylated histone peptide (final concentration ~50 nM).
 - Add serial dilutions of **(S)-GSK1379725A**.
 - Incubate at room temperature for a defined period (e.g., 30 minutes).
 - Add the Ni-NTA Acceptor beads and incubate.
 - Add the Streptavidin Donor beads and incubate in the dark.
- Data Acquisition and Analysis: Read the plate on an AlphaScreen-compatible plate reader. The signal will decrease as the inhibitor disrupts the protein-peptide interaction. Plot the signal against the inhibitor concentration and fit to a dose-response curve to determine the IC50 value.

Cellular Thermal Shift Assay (CETSA)

Objective: To confirm target engagement of **(S)-GSK1379725A** with BPTF in a cellular context.

Protocol:

- Cell Treatment: Culture a suitable cell line (e.g., one with high BPTF expression) and treat with **(S)-GSK1379725A** at various concentrations or a vehicle control (DMSO) for a specific duration (e.g., 1-2 hours).
- Heat Challenge: Harvest the cells, wash with PBS, and resuspend in a suitable buffer. Aliquot the cell suspension into PCR tubes and heat them to a range of temperatures (e.g., 40-70 °C) for a short period (e.g., 3 minutes) using a thermal cycler.
- Cell Lysis and Protein Quantification: Lyse the cells (e.g., by freeze-thaw cycles or sonication) and separate the soluble fraction from the aggregated proteins by centrifugation.
- Detection: Analyze the amount of soluble BPTF in the supernatant by Western blotting or other protein quantification methods like ELISA.

- Data Analysis: Plot the amount of soluble BPTF as a function of temperature for both treated and untreated samples. A shift in the melting curve to a higher temperature in the presence of **(S)-GSK1379725A** indicates target stabilization and engagement.

Assay for Transposase-Accessible Chromatin with sequencing (ATAC-seq)

Objective: To assess the genome-wide changes in chromatin accessibility upon treatment with **(S)-GSK1379725A**.

Protocol:

- Cell Treatment: Treat cells with **(S)-GSK1379725A** or a vehicle control.
- Nuclei Isolation: Harvest the cells and isolate intact nuclei.
- Transposition: Incubate the nuclei with a hyperactive Tn5 transposase pre-loaded with sequencing adapters. The transposase will fragment the DNA in open chromatin regions and simultaneously ligate the adapters.
- DNA Purification and Library Preparation: Purify the transposed DNA fragments and amplify them by PCR to generate a sequencing library.
- Sequencing and Data Analysis: Sequence the library on a high-throughput sequencing platform. Align the sequencing reads to the reference genome to identify regions of open chromatin. Compare the chromatin accessibility profiles between the **(S)-GSK1379725A**-treated and control samples to identify differential accessibility regions.

Conclusion

(S)-GSK1379725A is a valuable chemical probe for studying the biological functions of the BPTF bromodomain in chromatin remodeling and gene regulation. Its selectivity and characterized mechanism of action make it a useful tool for dissecting the role of the NURF complex in various physiological and pathological processes. The experimental protocols detailed in this guide provide a framework for the further investigation of **(S)-GSK1379725A** and the development of more potent and selective BPTF inhibitors for potential therapeutic applications.

Need Custom Synthesis?

BenchChem offers custom synthesis for rare earth carbides and specific isotopic labeling.

Email: info@benchchem.com or [Request Quote Online](#).

References

- [1. reactionbiology.com \[reactionbiology.com\]](https://www.reactionbiology.com)
- [2. pubs.acs.org \[pubs.acs.org\]](https://pubs.acs.org)
- [3. Real-Time Cellular Thermal Shift Assay to Monitor Target Engagement - PMC \[pmc.ncbi.nlm.nih.gov\]](https://pubmed.ncbi.nlm.nih.gov/36111111/)
- [4. Protocol for single-cell ATAC sequencing using combinatorial indexing in mouse lung adenocarcinoma - PMC \[pmc.ncbi.nlm.nih.gov\]](https://pubmed.ncbi.nlm.nih.gov/36111112/)
- To cite this document: BenchChem. [The Role of (S)-GSK1379725A in Chromatin Remodeling: A Technical Guide]. BenchChem, [2026]. [Online PDF]. Available at: [\[https://www.benchchem.com/product/b10800846/docs#the-role-of-s-gsk1379725a-in-chromatin-remodeling-a-technical-guide\]](https://www.benchchem.com/product/b10800846/docs#the-role-of-s-gsk1379725a-in-chromatin-remodeling-a-technical-guide)

Disclaimer & Data Validity:

The information provided in this document is for Research Use Only (RUO) and is strictly not intended for diagnostic or therapeutic procedures. While BenchChem strives to provide accurate protocols, we make no warranties, express or implied, regarding the fitness of this product for every specific experimental setup.

Technical Support: The protocols provided are for reference purposes. Unsure if this reagent suits your experiment?

Need Industrial/Bulk Grade? [Request Custom Synthesis Quote](#)

BenchChem

Our mission is to be the trusted global source of essential and advanced chemicals, empowering scientists and researchers to drive progress in science and industry.

Contact

Address: 3281 E Guasti Rd

Ontario, CA 91761, United States

Phone: (601) 213-4426

Email: info@benchchem.com

[Contact our Ph.D. Support Team for a compatibility check](#)