

Comparative Guide to Cross-Validation of Analytical Methods for Calcipotriol Impurity Profiling

Author: BenchChem Technical Support Team. **Date:** April 2026

Compound of Interest

Compound Name: *Impurity F of Calcipotriol*

Cat. No.: *B10800498*

[Get Quote](#)

For Researchers, Scientists, and Drug Development Professionals

This guide provides a comprehensive comparison of analytical methodologies for the profiling of impurities in Calcipotriol. Ensuring the purity of Calcipotriol, a synthetic vitamin D derivative used in the treatment of psoriasis, is critical for its safety and efficacy. This document outlines and compares various analytical techniques, offering insights into their performance based on published experimental data. The methodologies discussed are benchmarked against established analytical best practices and validation guidelines.

Overview of Calcipotriol Impurities

Impurities in Calcipotriol can stem from the manufacturing process (process-related impurities) or from the degradation of the drug substance over time when exposed to environmental factors like heat, light, moisture, and oxygen (degradation products).[1] Accurate detection and control of these impurities are crucial to guarantee the medication's safety and effectiveness.[1]

Commonly identified impurities include isomers of Calcipotriol, such as pre-Calcipotriol, which can be formed under thermal stress.[2][3][4] Forced degradation studies have shown that

Calcipotriol is susceptible to degradation under acidic, basic, oxidative, photolytic, and thermal conditions.[1][4]

Comparative Analysis of Analytical Methods

The primary analytical techniques for the assessment of Calcipotriol impurities are High-Performance Liquid Chromatography (HPLC) and Liquid Chromatography-Mass Spectrometry (LC-MS).

High-Performance Liquid Chromatography (HPLC)

Reverse-phase HPLC (RP-HPLC) is a widely used technique for the separation and quantification of Calcipotriol and its impurities.

A stability-indicating RP-HPLC method has been developed for the estimation of isomeric impurities of Calcipotriol, including pre-Calcipotriol.[2][4]

Experimental Protocol:

- Column: RP-C18, 150 × 4.6 mm, 2.7 μm particle size[2][4]
- Column Temperature: 50°C[2][4]
- Mobile Phase: A gradient mixture of water, methanol, acetonitrile, and tetrahydrofuran[2][4]
- Detection: UV detection at 264 nm for Calcipotriol and its impurities.[2][4] A Diode Array Detector (DAD) can be used to scan all separated peaks from 200 nm to 400 nm.[1][4]
- Sample Preparation: For ointment formulations, the sample can be dispersed in n-Hexane, followed by extraction with a suitable diluent and centrifugation.[2]

Performance Data:

Parameter	Value	Reference
Limit of Detection (LoD)	0.002 µg/mL	[2][4]
Limit of Quantification (LoQ)	0.006 µg/mL	[2][4]
Linearity Range	LoQ to 0.15 µg/mL	[2][4]
Accuracy & Precision	Within acceptance limits as per ICH guidelines	[2][4]

Another RP-HPLC method has been developed and validated for the determination of Calcipotriene in a cream formulation.[5]

Experimental Protocol:

- Column: Zorbax SB-300, C18[5]
- Mobile Phase: Methanol and water (70:30 v/v)[5]
- Flow Rate: 1.0 mL/min[5]
- Detection: UV at 264 nm[5]
- Injection Volume: 50 µL[5]
- Run Time: 7.5 min[5]

Performance Data:

Parameter	Value	Reference
Precision (RSD)	< 2%	[5]
Accuracy (% Recovery)	> 98%	[5]

Liquid Chromatography-Mass Spectrometry (LC-MS)

LC-MS and LC-MS/MS are powerful techniques for the identification and quantification of impurities, especially at trace levels.[6][7]

An LC-MS method has been described for the critical separation of Calcipotriol and its impurities.[1]

Experimental Protocol:

- Column: C18, 150 × 4.6 mm, 2.7 μm particle size[1]
- Column Temperature: 50°C[1]
- Mobile Phase A: Water:Methanol:THF (70:25:5 v/v/v)[1]
- Mobile Phase B: Acetonitrile:Water:THF (90:5:5 v/v/v)[1]
- Gradient Elution: A detailed gradient program is utilized for separation.[1]
- Injection Volume: 20 μL[1]
- Detection: Mass Spectrometry[1]

An advanced UHPLC/MSE method has been employed for the determination of Calcipotriol and its photodegradation products.[3]

Experimental Protocol:

- This method is particularly useful for identifying unknown degradation products formed under photolytic stress.[3] The specific chromatographic conditions are detailed in the referenced study.

A sensitive LC-MS/MS method has been developed to evaluate the permeation and retention of Calcipotriol in skin samples.[8] While focused on pharmacokinetics, the methodology is relevant for impurity analysis in biological matrices.

Experimental Protocol:

- Column: Extend-C18[8]

- Mobile Phase: Isocratic elution[8]
- Detection: Electrospray ionization in negative ion mode with multiple-reaction monitoring (MRM)[8]
- Precursor to Product Ion Transition: m/z 411.1 \rightarrow 393.5 for Calcipotriol[8]

Performance Data:

Matrix	LLOQ	Reference
Skin Homogenate	1 ng/mL	[8]
Receptor Medium	0.5 ng/mL	[8]
Ointment Samples	40 ng/mL	[8]

Cross-Validation of Analytical Methods

Cross-validation is the process of comparing results from at least two different analytical methods or from the same method used in different laboratories to ensure the data is comparable and reliable.[9][10] A comprehensive impurity profiling strategy for Calcipotriol should ideally leverage a combination of HPLC and LC-MS techniques.

Workflow for Cross-Validation

The following diagram illustrates a general workflow for the cross-validation of analytical methods for Calcipotriol impurity profiling.

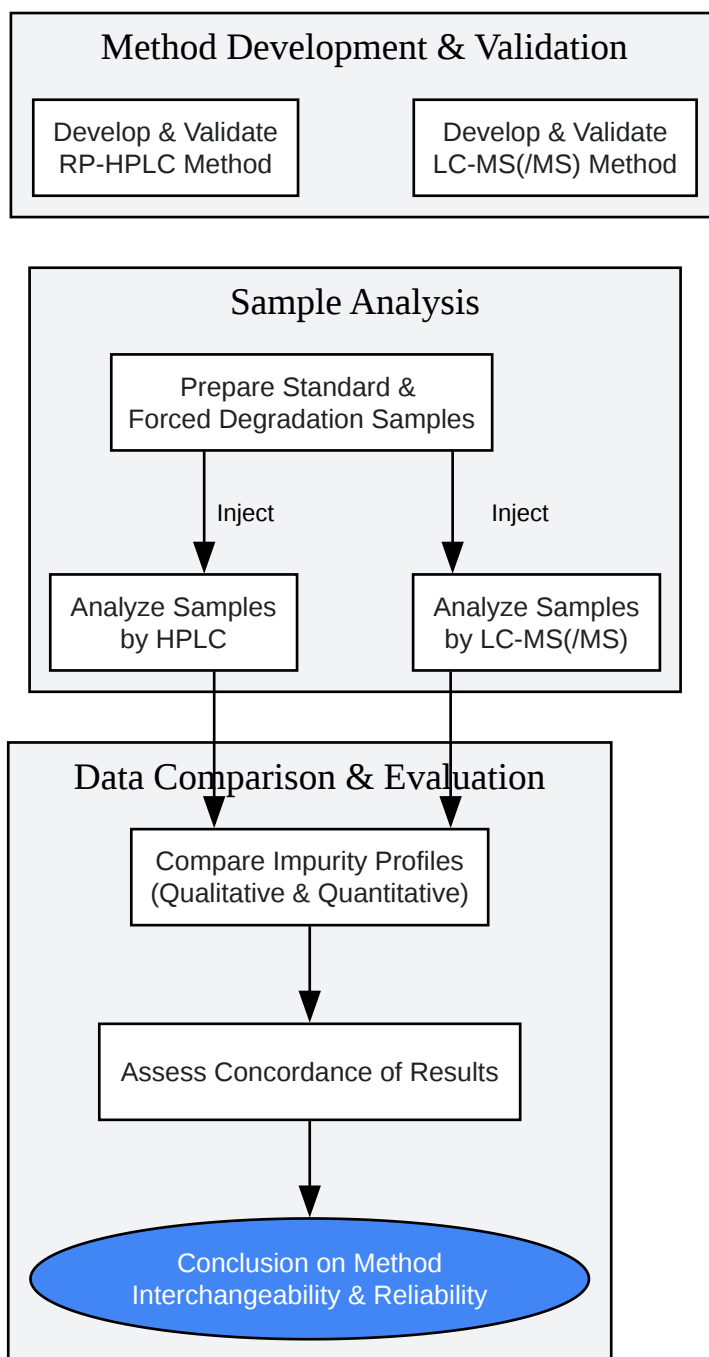

[Click to download full resolution via product page](#)

Caption: Workflow for the cross-validation of analytical methods.

Calcipotriol Degradation Pathway

Understanding the degradation pathways is crucial for identifying potential impurities. The following diagram illustrates a simplified degradation pathway for Calcipotriol.

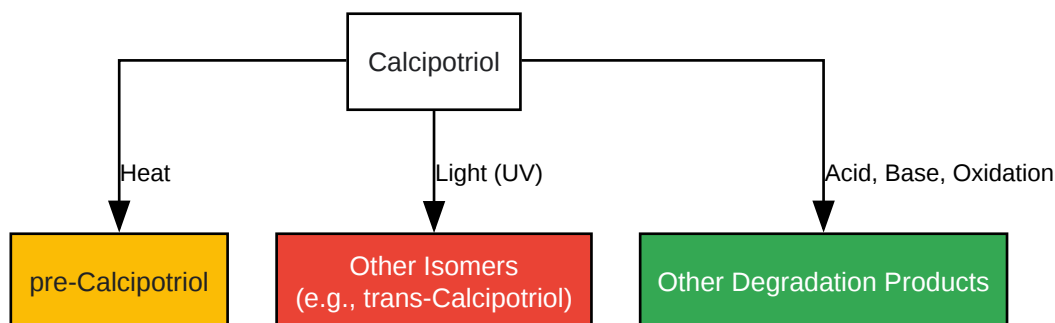

[Click to download full resolution via product page](#)

Caption: Simplified degradation pathway of Calcipotriol.

Conclusion

The choice of analytical method for the impurity profiling of Calcipotriol depends on the specific requirements of the analysis. RP-HPLC with UV detection is a robust and reliable method for routine quality control and quantification of known impurities. LC-MS and UHPLC-MS are indispensable for the identification of unknown impurities, particularly those formed during forced degradation studies, and for the analysis of trace-level impurities.

A comprehensive approach to Calcipotriol impurity profiling should involve the use of orthogonal methods, such as HPLC and LC-MS. Cross-validation of these methods is essential to ensure the generation of reliable and comprehensive data, ultimately safeguarding the quality, safety, and efficacy of Calcipotriol-containing drug products.

Need Custom Synthesis?

BenchChem offers custom synthesis for rare earth carbides and specific isotopic labeling.

Email: info@benchchem.com or [Request Quote Online](#).

References

- 1. bocsci.com [bocsci.com]

- [2. Stability Indicating RP-HPLC Method for Estimation of Impurities of Vitamin D3 Analogue and Corticosteroid Used as Antipsoriatic Drugs. An Attempt to Characterize Pre-Calcioptriene \[scirp.org\]](#)
- [3. mdpi.com \[mdpi.com\]](#)
- [4. scirp.org \[scirp.org\]](#)
- [5. rjptonline.org \[rjptonline.org\]](#)
- [6. resolvemass.ca \[resolvemass.ca\]](#)
- [7. chimia.ch \[chimia.ch\]](#)
- [8. Evaluation of calcipotriol transdermal permeation through pig, rat and mouse skin using liquid chromatography-tandem mass spectrometry - PubMed \[pubmed.ncbi.nlm.nih.gov\]](#)
- [9. pharmaguru.co \[pharmaguru.co\]](#)
- [10. Method Transfer, Partial Validation, and Cross Validation: Recommendations for Best Practices and Harmonization from the Global Bioanalysis Consortium Harmonization Team - PMC \[pmc.ncbi.nlm.nih.gov\]](#)
- [To cite this document: BenchChem. \[Comparative Guide to Cross-Validation of Analytical Methods for Calcipotriol Impurity Profiling\]. BenchChem, \[2026\]. \[Online PDF\]. Available at: \[https://www.benchchem.com/product/b10800498/docs#comparative-guide-to-cross-validation-of-analytical-methods-for-calcipotriol-impurity-profiling\]](#)

Disclaimer & Data Validity:

The information provided in this document is for Research Use Only (RUO) and is strictly not intended for diagnostic or therapeutic procedures. While BenchChem strives to provide accurate protocols, we make no warranties, express or implied, regarding the fitness of this product for every specific experimental setup.

Technical Support: The protocols provided are for reference purposes. Unsure if this reagent suits your experiment?

Need Industrial/Bulk Grade? [Request Custom Synthesis Quote](#)

BenchChem

Our mission is to be the trusted global source of essential and advanced chemicals, empowering scientists and researchers to drive progress in science and industry.

Contact

Address: 3281 E Guasti Rd

Ontario, CA 91761, United States

Phone: (601) 213-4426

Email: info@benchchem.com

[Contact our Ph.D. Support Team for a compatibility check](#)