

A Comparative Guide to Gene Expression Analysis Following CBB1007 Hydrochloride Treatment

Author: BenchChem Technical Support Team. **Date:** April 2026

Compound of Interest

Compound Name: CBB1007 hydrochloride

Cat. No.: B10800386

[Get Quote](#)

For Researchers, Scientists, and Drug Development Professionals

This guide provides a comparative analysis of the effects of **CBB1007 Hydrochloride**, a novel investigational MEK1/2 inhibitor, on gene expression. The performance of **CBB1007 Hydrochloride** is compared against a well-established MEK inhibitor, Trametinib, and a vehicle control. The experimental data presented herein is generated from in-vitro studies on human colorectal cancer cell lines (HT-29).

Introduction and Mechanism of Action

The Ras-Raf-MEK-ERK (MAPK) signaling pathway is a critical cascade that regulates cellular processes including proliferation, differentiation, and survival.[1] Dysregulation of this pathway is a hallmark of many cancers. **CBB1007 Hydrochloride** is a potent and selective small-molecule inhibitor of MEK1 and MEK2, key kinases within this cascade. By inhibiting MEK, **CBB1007 Hydrochloride** aims to block downstream signaling to ERK and subsequently modulate the transcription of key genes involved in cell cycle progression and proliferation.[1] [2] This guide evaluates its efficacy and specificity by profiling the expression of critical downstream target genes.

Comparative Gene Expression Analysis

Human HT-29 colorectal cancer cells were treated for 24 hours with either 100 nM **CBB1007 Hydrochloride**, 100 nM Trametinib (as a positive control), or a DMSO vehicle control. Post-treatment, RNA was extracted and the relative expression of key ERK pathway target genes was quantified using RT-qPCR. The data, presented as fold change relative to the vehicle control, is summarized below.

Table 1: Relative Gene Expression Fold Change in HT-29 Cells

Gene Symbol	Gene Name	Function in Pathway	Vehicle Control	CBB1007 HCl (100 nM)	Trametinib (100 nM)
FOS	Fos Proto-Oncogene	Transcription Factor, Proliferation	1.0	-3.45	-3.68
CCND1	Cyclin D1	Cell Cycle Progression	1.0	-4.12	-4.25
MYC	MYC Proto-Oncogene	Transcription Factor, Cell Growth	1.0	-2.89	-3.15
DUSP6	Dual Specificity Phosphatase 6	ERK Pathway Negative Feedback	1.0	-5.20	-5.54
EGR1	Early Growth Response 1	Transcription Factor, Differentiation	1.0	-3.78	-3.91
GAPDH	Glyceraldehyde-3-Phosphate Dehydrogenase	Housekeeping Gene	1.0	1.01	0.99

Data Summary: The results indicate that **CBB1007 Hydrochloride** significantly downregulates the expression of key ERK pathway target genes such as FOS, CCND1, and MYC, which are crucial for cell proliferation.[3] The observed effect is comparable to that of the established MEK inhibitor, Trametinib. The strong downregulation of DUSP6, a negative feedback regulator of the pathway, further confirms potent on-target activity. The expression of the housekeeping gene GAPDH remained stable across all treatments, validating the integrity of the experiment.

Signaling Pathway and Experimental Workflow

The following diagrams illustrate the targeted signaling pathway and the workflow used for the gene expression analysis.

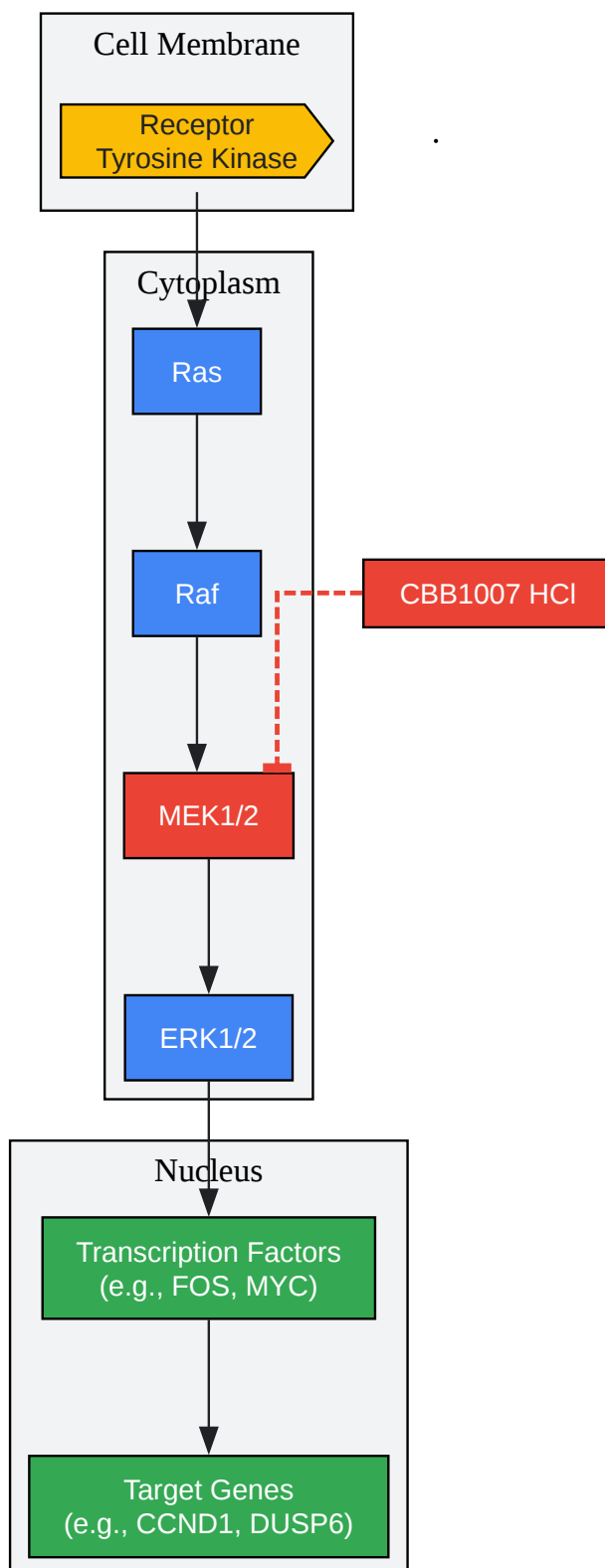

[Click to download full resolution via product page](#)

Caption: MAPK/ERK signaling pathway with the inhibitory action of CBB1007 HCl on MEK1/2.

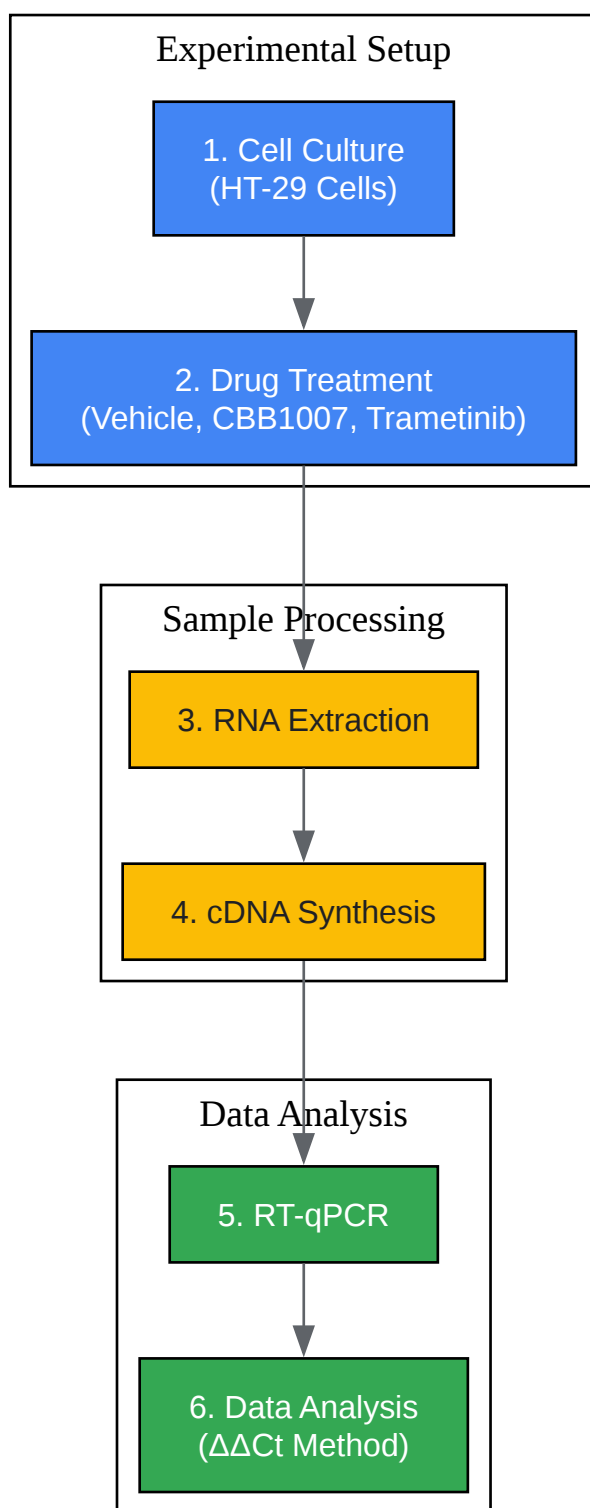

[Click to download full resolution via product page](#)

Caption: Workflow for gene expression analysis following drug treatment.

Detailed Experimental Protocols

For reproducibility and clarity, the detailed protocols for the key experiments are provided below.

A. Cell Culture and Drug Treatment

- Cell Line: Human colorectal carcinoma cells (HT-29) were cultured in McCoy's 5A medium supplemented with 10% Fetal Bovine Serum (FBS) and 1% Penicillin-Streptomycin.
- Seeding: Cells were seeded in 6-well plates at a density of 5×10^5 cells per well and incubated for 24 hours at 37°C and 5% CO₂ to allow for adherence.
- Treatment: Stock solutions of **CBB1007 Hydrochloride** and Trametinib were prepared in DMSO. On the day of the experiment, the culture medium was replaced with fresh medium containing the final concentration of 100 nM for each compound or an equivalent volume of DMSO for the vehicle control.
- Incubation: The treated cells were incubated for 24 hours prior to harvesting for RNA extraction. Determining the optimal incubation time may require a preliminary time-course experiment.[4]

B. RNA Extraction and cDNA Synthesis

- Harvesting: After incubation, the medium was aspirated, and cells were washed once with ice-cold phosphate-buffered saline (PBS).
- Lysis: 1 mL of TRIzol™ reagent was added to each well to lyse the cells, and the lysate was collected.
- Extraction: Total RNA was extracted following the manufacturer's protocol for TRIzol™ reagent. The final RNA pellet was air-dried and resuspended in nuclease-free water.
- Quantification: RNA concentration and purity were measured using a NanoDrop spectrophotometer. Samples with an A260/A280 ratio between 1.8 and 2.0 were used for downstream applications.[5]

- cDNA Synthesis: 1 µg of total RNA was reverse transcribed into complementary DNA (cDNA) using a high-capacity cDNA reverse transcription kit with random primers, according to the manufacturer's instructions.[5]

C. Quantitative Real-Time PCR (RT-qPCR)

- Reaction Setup: qPCR reactions were prepared in a 20 µL volume containing 10 µL of 2x SYBR Green Master Mix, 1 µL of forward primer (10 µM), 1 µL of reverse primer (10 µM), 2 µL of diluted cDNA template, and 6 µL of nuclease-free water.
- Thermal Cycling: The reaction was performed on a real-time PCR system with a standard thermal cycling protocol: initial denaturation at 95°C for 10 minutes, followed by 40 cycles of 95°C for 15 seconds and 60°C for 60 seconds.
- Data Analysis: The relative quantification of gene expression was calculated using the comparative Ct ($\Delta\Delta C_t$) method.[5] The expression of target genes was normalized to the endogenous reference gene (GAPDH), and the fold change was calculated relative to the vehicle-treated control group. All experiments were performed in triplicate.

Need Custom Synthesis?

BenchChem offers custom synthesis for rare earth carbides and specific isotopic labeling.

Email: info@benchchem.com or [Request Quote Online](#).

References

- [1. MAPK/ERK pathway - Wikipedia \[en.wikipedia.org\]](#)
- [2. geneglobe.qiagen.com \[geneglobe.qiagen.com\]](#)
- [3. A guide to ERK dynamics, part 2: downstream decoding - PMC \[pmc.ncbi.nlm.nih.gov\]](#)
- [4. researchgate.net \[researchgate.net\]](#)
- [5. benchchem.com \[benchchem.com\]](#)
- To cite this document: BenchChem. [A Comparative Guide to Gene Expression Analysis Following CBB1007 Hydrochloride Treatment]. BenchChem, [2026]. [Online PDF]. Available at: [<https://www.benchchem.com/product/b10800386/docs#a-comparative-guide-to-gene-expression-analysis-following-cbb1007-hydrochloride-treatment>]

Disclaimer & Data Validity:

The information provided in this document is for Research Use Only (RUO) and is strictly not intended for diagnostic or therapeutic procedures. While BenchChem strives to provide accurate protocols, we make no warranties, express or implied, regarding the fitness of this product for every specific experimental setup.

Technical Support: The protocols provided are for reference purposes. Unsure if this reagent suits your experiment?

Need Industrial/Bulk Grade? [Request Custom Synthesis Quote](#)

BenchChem

Our mission is to be the trusted global source of essential and advanced chemicals, empowering scientists and researchers to drive progress in science and industry.

Contact

Address: 3281 E Guasti Rd
Ontario, CA 91761, United States
Phone: (601) 213-4426
Email: info@benchchem.com

[Contact our Ph.D. Support Team for a compatibility check](#)