

Technical Support Center: S 33138 & rac-S 33138 Optimization

Author: BenchChem Technical Support Team. **Date:** May 2026

Compound of Interest

Compound Name: *rac S 33138*
CAS No.: 220647-56-3
Cat. No.: B108224

[Get Quote](#)

Topic: Troubleshooting Off-Target D2 Receptor Effects with S 33138

Content ID: TSC-D3-0042 Last Updated: February 20, 2026

Executive Summary: The Selectivity Challenge

S 33138 is a preferential dopamine D3 receptor antagonist.^{[1][2][3][4]} However, users frequently encounter off-target D2 receptor blockade (manifesting as catalepsy in vivo or unintended signal inhibition in vitro). This is often due to the Selectivity Window Paradox: S 33138 has only a ~25–50 fold selectivity ratio for D3 over D2.

Critical Note on Stereochemistry: S 33138 is a chiral molecule with a specific (3aS, 9bR) configuration [1].

- S 33138 (Pure): High affinity D3 antagonist (nM).

- rac-S 33138 (Racemate): A mixture of the active enantiomer and its mirror image.[5] Using the racemate effectively "dilutes" the D3 affinity while potentially maintaining or altering D2 liability, narrowing the already tight selectivity window.

Diagnostic Workflow: Why are you seeing D2 effects?

If you observe D2-mediated effects (e.g., catalepsy, prolactin release, or displacement of D2-specific radioligands), follow this diagnostic tree.

Interactive Troubleshooting Diagram

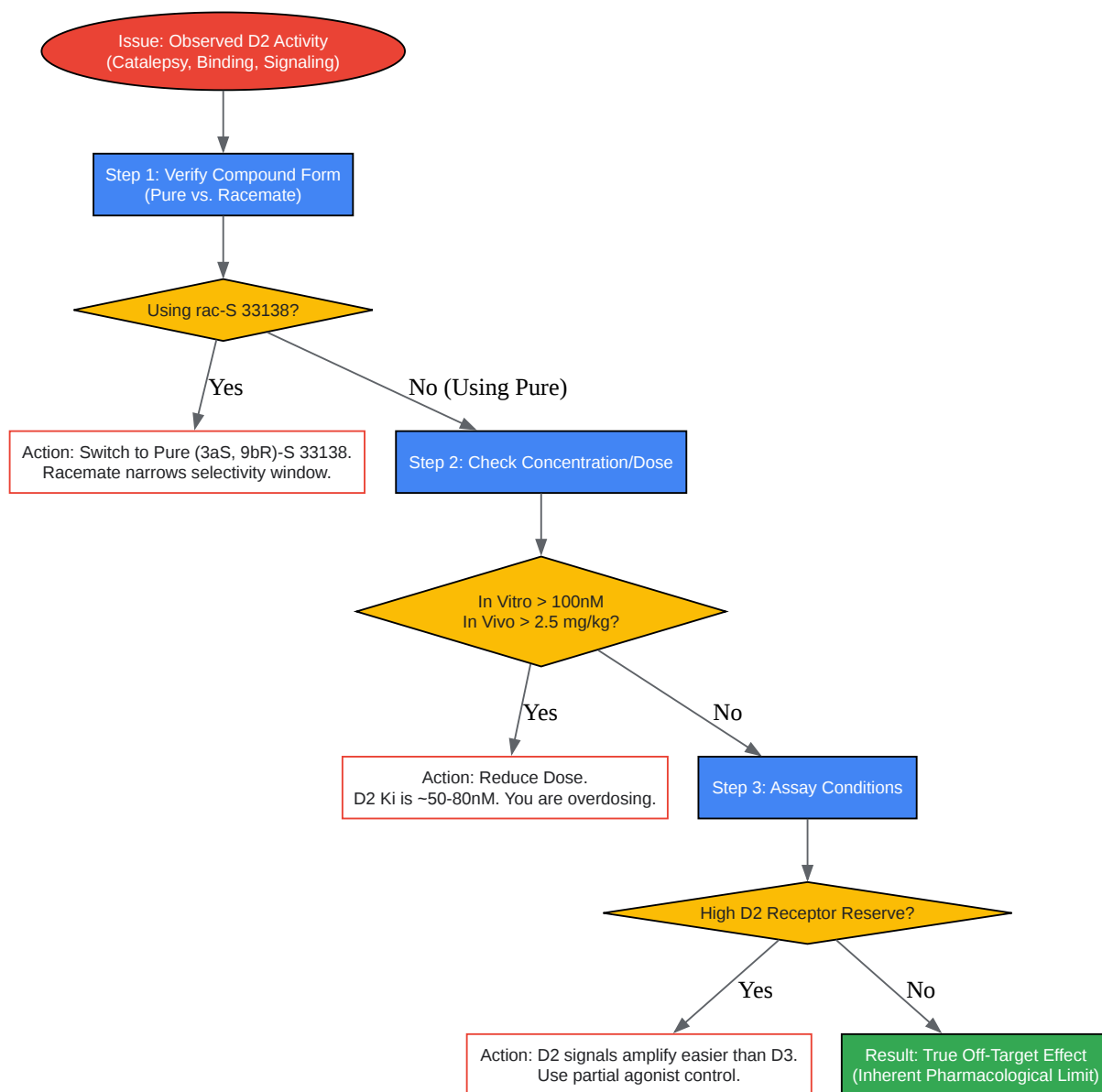

[Click to download full resolution via product page](#)

Caption: Diagnostic logic for identifying the source of D2 interference when using S 33138.

Technical FAQs & Troubleshooting Guides

Scenario A: "I bought 'rac-S 33138' to save money, but my D3 knockdown is weak and I see D2 side effects."

Root Cause: The "rac" prefix indicates a racemic mixture (50% active (3aS, 9bR) enantiomer, 50% distomer).

- Potency Shift: You effectively have half the concentration of the active D3 antagonist. To achieve the same D3 blockade, you likely doubled the dose.
- The Distomer Risk: The inactive enantiomer (distomer) is rarely biologically inert. It may have a lower selectivity ratio, binding D2 receptors with sufficient affinity to trigger off-target effects when the total mass dose is increased [2].

Solution Protocol:

- Immediate: Calculate your molarity based on the active enantiomer (assume 50% purity).
- Correction: If you must use the racemate, titrate carefully. Do not exceed 100 nM in vitro.
- Recommendation: Switch to the enantiopure form for any in vivo behavioral study to avoid confounding catalepsy data.

Scenario B: "In my binding assay, S 33138 displaces [3H]-Raclopride (a D2 ligand)."

Root Cause: S 33138 is a preferential, not specific, antagonist.[1][3][4][6][7] It binds D2 receptors with a

of approximately 50–80 nM [1]. If you use a high concentration (e.g., 1

M) to ensure D3 saturation, you will inevitably occupy D2 receptors.

Data Comparison Table: Binding Affinities (

)

Receptor Subtype	S 33138 Affinity (nM)	Selectivity Ratio (vs D3)
D3 (Human)	8.7 – 8.9	1 (Target)
D2L (Long)	7.1	~40-fold
D2S (Short)	7.3	~25-fold
D1	6.3	>250-fold
5-HT2A	6.8	>75-fold

Data derived from Millan et al. [1].[2][3][4][8] Note the narrow window between D3 and D2S.

Troubleshooting Protocol:

- Define the Window: Perform a competition binding curve. You should see a biphasic displacement if receptor density is high, or a shift in .
- The "Sweet Spot": Use S 33138 at 10–20 nM. At this concentration, D3 occupancy is >90%, while D2 occupancy remains <20%.

Scenario C: "My mice are showing catalepsy at 10 mg/kg."

Root Cause: Catalepsy is a hallmark of D2 blockade (striatal motor control). S 33138 does not induce catalepsy at selective doses (< 2.5 mg/kg s.c.). At 10 mg/kg, plasma concentrations exceed the

for striatal D2 receptors [3].

In Vivo Dosing Guide:

- Cognitive Enhancement (D3 Selective): 0.16 – 0.63 mg/kg (s.c. or i.p.).
- Addiction Models (D3 Selective): 0.63 – 2.5 mg/kg.

- Loss of Selectivity (D2 Onset): > 2.5 mg/kg.[2][6]
- Catalepsy Threshold: > 10.0 mg/kg.[4][6]

Mechanistic Insight: D3 vs. D2 Signaling

Understanding the signaling divergence helps in designing functional assays that distinguish D3 activity from D2 interference. While both couple to

, their downstream regulation differs in specific cell types.

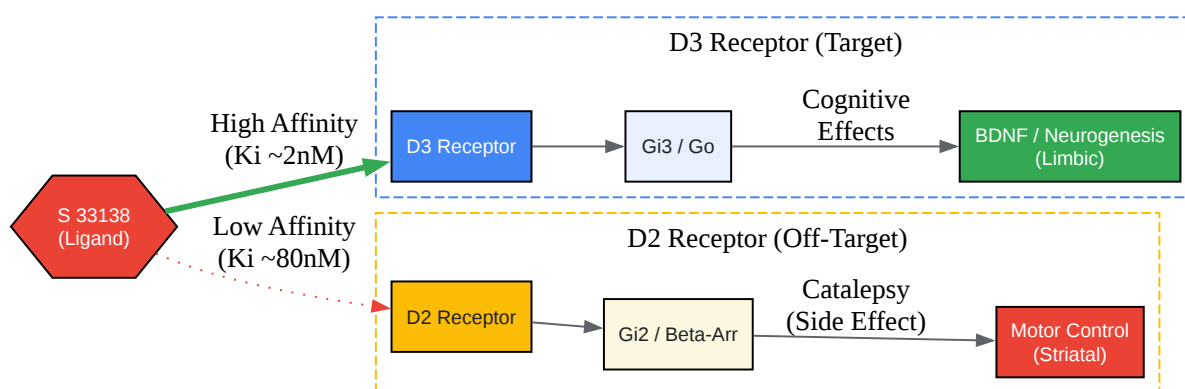

[Click to download full resolution via product page](#)

Caption: S 33138 preferentially binds D3, driving cognitive benefits.[2][4][6][8] High concentrations spill over to D2, triggering motor side effects.

References

- Millan, M. J., et al. (2008).[2][3][4][6] S33138, a preferential dopamine D3 versus D2 receptor antagonist and potential antipsychotic agent: I. Receptor-binding profile and functional actions at G-protein-coupled receptors.[7] *Journal of Pharmacology and Experimental Therapeutics*, 324(2), 587-599.[7]
- Lappalainen, J., et al. (2011). The effects of the preferential dopamine D3 receptor antagonist S33138 on ethanol binge-drinking in C57BL/6J mice.[1] *Psychopharmacology*,

218(1), 219-228.

- Millan, M. J., et al. (2008).^{[2][4][6]} S33138... II. Actions in models of therapeutic activity and induction of side effects.^{[4][6]} *Journal of Pharmacology and Experimental Therapeutics*, 324(2), 600-611.

Need Custom Synthesis?

BenchChem offers custom synthesis for rare earth carbides and specific isotopic labeling.

Email: info@benchchem.com or [Request Quote Online](#).

Sources

- 1. The Effects of the Preferential Dopamine D3 Receptor Antagonist S33138 on Ethanol Binge-Drinking in C57BL/6J Mice - PMC [[pmc.ncbi.nlm.nih.gov](https://pubmed.ncbi.nlm.nih.gov/)]
- 2. academic.oup.com [academic.oup.com]
- 3. The preferential dopamine D3 receptor antagonist S33138 inhibits cocaine reward and cocaine-triggered relapse to drug-seeking behavior in rats - PMC [[pmc.ncbi.nlm.nih.gov](https://pubmed.ncbi.nlm.nih.gov/)]
- 4. Redirecting [linkinghub.elsevier.com]
- 5. Chirality (chemistry) - Wikipedia [en.wikipedia.org]
- 6. S33138 (N-[4-[2-[(3aS,9bR)-8-cyano-1,3a,4,9b-tetrahydro[1] benzopyrano[3,4-c]pyrrol-2(3H)-yl)-ethyl]phenyl]acetamide), a preferential dopamine D3 versus D2 receptor antagonist and potential antipsychotic agent: III. Actions in models of therapeutic activity and induction of side effects - PubMed [pubmed.ncbi.nlm.nih.gov]
- 7. S33138 [N-[4-[2-[(3aS,9bR)-8-cyano-1,3a,4,9b-tetrahydro[1]-benzopyrano[3,4-c]pyrrol-2(3H)-yl)-ethyl]phenyl]acetamide], a preferential dopamine D3 versus D2 receptor antagonist and potential antipsychotic agent: I. Receptor-binding profile and functional actions at G-protein-coupled receptors - PubMed [pubmed.ncbi.nlm.nih.gov]
- 8. Selective Blockade of Dopamine D3 Receptors Enhances while D2 Receptor Antagonism Impairs Social Novelty Discrimination and Novel Object Recognition in Rats: A Key Role for the Prefrontal Cortex - PMC [[pmc.ncbi.nlm.nih.gov](https://pubmed.ncbi.nlm.nih.gov/)]
- To cite this document: BenchChem. [Technical Support Center: S 33138 & rac-S 33138 Optimization]. BenchChem, [2026]. [Online PDF]. Available at: [<https://www.benchchem.com/product/b108224/docs#technical-support-center-s-33138-rac-s-33138-optimization>]

Disclaimer & Data Validity:

The information provided in this document is for Research Use Only (RUO) and is strictly not intended for diagnostic or therapeutic procedures. While BenchChem strives to provide accurate protocols, we make no warranties, express or implied, regarding the fitness of this product for every specific experimental setup.

Technical Support: The protocols provided are for reference purposes. Unsure if this reagent suits your experiment?

Need Industrial/Bulk Grade? [Request Custom Synthesis Quote](#)

BenchChem

Our mission is to be the trusted global source of essential and advanced chemicals, empowering scientists and researchers to drive progress in science and industry.

Contact

Address: 3281 E Guasti Rd
Ontario, CA 91761, United States
Phone: (601) 213-4426
Email: info@benchchem.com

[Contact our Ph.D. Support Team for a compatibility check](#)