

# Technical Support Center: Addressing Variability in NRP-1 Expression in Tumors

**Author:** BenchChem Technical Support Team. **Date:** April 2026

## Compound of Interest

Compound Name: *iRGD peptide*

Cat. No.: *B10799724*

[Get Quote](#)

This technical support center provides troubleshooting guidance and frequently asked questions (FAQs) for researchers, scientists, and drug development professionals investigating Neupilin-1 (NRP-1) expression in tumors.

## Frequently Asked Questions (FAQs)

Q1: Why is there significant variability in NRP-1 expression across different tumor types?

A1: Neupilin-1 (NRP-1) expression is highly variable across different cancer types due to its complex role in tumor biology.<sup>[1][2]</sup> This variability is influenced by the specific tumor microenvironment, the stage of the tumor, and the molecular subtype of the cancer. For instance, some cancer cells express NRP-1 to promote angiogenesis and metastasis, while in other contexts, its expression might be linked to different cellular processes.<sup>[2][3]</sup>

Q2: What is the clinical significance of variable NRP-1 expression?

A2: High NRP-1 expression often correlates with poor prognosis, increased tumor aggressiveness, and metastasis in various malignancies, including non-small cell lung cancer (NSCLC), breast cancer, and melanoma.<sup>[2][4]</sup> Therefore, NRP-1 is considered a potential prognostic biomarker and a promising therapeutic target.<sup>[1][2]</sup>

Q3: What are the primary signaling pathways involving NRP-1 in cancer?

A3: NRP-1 is a co-receptor that modulates several key signaling pathways crucial for tumor progression.<sup>[1][2]</sup> The most well-characterized pathways include:

- **VEGF Signaling:** NRP-1 enhances the binding of Vascular Endothelial Growth Factor (VEGF) to its receptor VEGFR2, promoting angiogenesis, tumor cell survival, and migration.<sup>[2][4][5]</sup>
- **TGF- $\beta$  Signaling:** NRP-1 can interact with Transforming Growth Factor-beta (TGF- $\beta$ ) receptors, influencing processes like epithelial-mesenchymal transition (EMT) and cell invasion.<sup>[1][2]</sup>
- **PI3K/Akt Pathway:** NRP-1 signaling can lead to the activation of the PI3K/Akt pathway, which is central to cell proliferation, survival, and growth.<sup>[4][5]</sup>
- **Semaphorin Signaling:** As a receptor for semaphorins, NRP-1 can mediate signals that affect cell migration and invasion.<sup>[2]</sup>

## Troubleshooting Guides

This section provides troubleshooting for common issues encountered during the detection and quantification of NRP-1 expression using Immunohistochemistry (IHC), Western Blot, and Flow Cytometry.

### Immunohistochemistry (IHC) Troubleshooting

Problem	Possible Cause	Recommended Solution
Weak or No Staining	Inadequate antigen retrieval.	Optimize antigen retrieval method (heat-induced or enzymatic). Ensure correct buffer pH and incubation time. [6]
Low primary antibody concentration.	Increase the primary antibody concentration or extend the incubation time (e.g., overnight at 4°C).[7][8]	
Primary antibody not suitable for IHC.	Confirm that the antibody is validated for IHC on the specific tissue type and fixation method used.[9]	
Tissue over-fixation.	Use freshly prepared fixative and adhere to recommended fixation times.	
High Background Staining	Non-specific binding of secondary antibody.	Include a blocking step with normal serum from the same species as the secondary antibody.[7] Ensure secondary antibody is cross-adsorbed.
Endogenous peroxidase or phosphatase activity.	Perform a peroxidase or phosphatase blocking step before primary antibody incubation.[7]	
Primary antibody concentration too high.	Titrate the primary antibody to determine the optimal concentration.[9]	
Inadequate washing.	Increase the number and duration of wash steps.[6][7]	

<p>Non-Specific Staining</p>	<p>Cross-reactivity of the primary or secondary antibody.</p>	<p>Run a negative control (without primary antibody) to check for secondary antibody non-specificity. Use a more specific primary antibody if necessary. <a href="#">[10]</a></p>
<p>Tissue drying out during staining.</p>	<p>Keep the tissue section covered with buffer at all times during the staining procedure. <a href="#">[9]</a></p>	
<p>Incomplete deparaffinization.</p>	<p>Use fresh xylene and ensure adequate deparaffinization time. <a href="#">[10]</a></p>	

## Western Blot Troubleshooting

Problem	Possible Cause	Recommended Solution
Weak or No Signal	Insufficient protein transfer.	Confirm transfer by staining the membrane with Ponceau S. Optimize transfer time and voltage. For larger proteins, consider a wet transfer system. <a href="#">[11]</a> <a href="#">[12]</a>
Low primary antibody concentration.	Increase the primary antibody concentration or incubate overnight at 4°C. <a href="#">[8]</a> <a href="#">[11]</a>	
Low abundance of NRP-1 in the sample.	Increase the amount of protein loaded onto the gel. Consider enriching for NRP-1 via immunoprecipitation. <a href="#">[12]</a>	
Inactive secondary antibody or substrate.	Use fresh substrate and ensure the secondary antibody is active and appropriate for the primary antibody.	
High Background	Insufficient blocking.	Increase blocking time or try a different blocking agent (e.g., BSA instead of milk). <a href="#">[11]</a>
Primary or secondary antibody concentration too high.	Reduce the antibody concentrations. <a href="#">[8]</a> <a href="#">[11]</a>	
Inadequate washing.	Increase the number and duration of washes with buffer containing a detergent like Tween-20. <a href="#">[11]</a>	
Non-Specific Bands	Primary antibody is not specific enough.	Use a different, more specific primary antibody. Perform a BLAST search to check for potential cross-reactivity.

---

Protein degradation.	Add protease inhibitors to the lysis buffer and keep samples on ice. <a href="#">[13]</a>
----------------------	---

---

Too much protein loaded.	Reduce the amount of protein loaded per lane. <a href="#">[11]</a>
--------------------------	--

---

## Flow Cytometry Troubleshooting

Problem	Possible Cause	Recommended Solution
Weak or No Signal	Low NRP-1 expression on the cell surface.	Confirm NRP-1 expression with a more sensitive technique like qPCR or Western Blot. Use a brighter fluorochrome-conjugated antibody. <a href="#">[14]</a> <a href="#">[15]</a>
Antibody concentration is too low.	Titrate the antibody to find the optimal concentration. <a href="#">[14]</a> <a href="#">[16]</a>	
Inadequate instrument settings.	Ensure laser alignment and detector voltages are optimized using compensation controls. <a href="#">[16]</a>	
Cell permeabilization (if detecting intracellular NRP-1).	Optimize the permeabilization protocol; some epitopes are sensitive to certain detergents.	
High Background	Non-specific antibody binding.	Include an isotype control to assess non-specific binding. Block Fc receptors with an Fc blocking reagent. <a href="#">[15]</a> <a href="#">[17]</a>
Dead cells.	Use a viability dye to exclude dead cells from the analysis, as they can non-specifically bind antibodies. <a href="#">[16]</a>	
Insufficient washing.	Increase the number of wash steps after antibody incubation. <a href="#">[14]</a>	
Poor Resolution/Abnormal Scatter	Cell clumps.	Gently pipette or filter the cell suspension before analysis.
Debris or dead cells.	Use a viability dye and gate on the live cell population based	

on forward and side scatter.

[\[14\]](#)

Instrument not calibrated.

Run calibration beads to ensure the instrument is properly aligned and functioning.

## Quantitative Data on NRP-1 Expression

The following table summarizes representative data on NRP-1 mRNA expression levels across different cancer types, highlighting the variability. Data is presented as Transcripts Per Million (TPM).

Cancer Type	Mean NRP-1 mRNA Expression (RSEM)	Reference
Clear Cell Renal Cell Carcinoma (ccRCC)	10,391	<a href="#">[18]</a>
Skin Cutaneous Melanoma (SKCM)	-	<a href="#">[18]</a>
Endometrial Cancer (G1)	Lower Expression	<a href="#">[19]</a>
Endometrial Cancer (G2 & G3)	~190% of G1	<a href="#">[19]</a>
Lung Cancer (A549 cells)	76.8 ± 13% NRP-1 positive cells	<a href="#">[20]</a>
Lung Cancer (Calu-1 cells)	86.6 ± 4% NRP-1 positive cells	<a href="#">[20]</a>

Note: RSEM (RNA-Seq by Expectation-Maximization) is a measure of gene expression. Higher values indicate higher expression.

## Experimental Protocols

### Immunohistochemistry (IHC) Protocol for NRP-1

- Deparaffinization and Rehydration:

- Immerse slides in xylene (2 x 5 minutes).
- Rehydrate through graded ethanol solutions: 100% (2 x 3 minutes), 95% (1 x 3 minutes), 70% (1 x 3 minutes).
- Rinse with distilled water.
- Antigen Retrieval:
  - Perform heat-induced epitope retrieval (HIER) using a citrate buffer (pH 6.0) or Tris-EDTA buffer (pH 9.0) at 95-100°C for 20-30 minutes.
  - Allow slides to cool to room temperature.
- Peroxidase Blocking:
  - Incubate sections with 3% hydrogen peroxide for 10-15 minutes to block endogenous peroxidase activity.
  - Rinse with PBS.
- Blocking:
  - Incubate with a blocking solution (e.g., 5% normal goat serum in PBS) for 1 hour at room temperature to prevent non-specific antibody binding.
- Primary Antibody Incubation:
  - Incubate with anti-NRP-1 primary antibody diluted in blocking solution overnight at 4°C.
- Secondary Antibody Incubation:
  - Wash slides with PBS (3 x 5 minutes).
  - Incubate with a biotinylated secondary antibody for 1 hour at room temperature.
- Detection:
  - Wash slides with PBS (3 x 5 minutes).

- Incubate with a streptavidin-HRP conjugate for 30 minutes.
- Wash slides with PBS (3 x 5 minutes).
- Chromogen Development:
  - Apply DAB substrate and monitor for color development.
  - Stop the reaction by rinsing with distilled water.
- Counterstaining, Dehydration, and Mounting:
  - Counterstain with hematoxylin.
  - Dehydrate through graded ethanol and clear in xylene.
  - Mount with a permanent mounting medium.

## Western Blot Protocol for NRP-1

- Protein Extraction:
  - Lyse cells or tissues in RIPA buffer containing protease and phosphatase inhibitors.
  - Centrifuge to pellet cell debris and collect the supernatant.
  - Determine protein concentration using a BCA or Bradford assay.
- SDS-PAGE:
  - Mix protein lysates with Laemmli sample buffer and heat at 95°C for 5 minutes.
  - Load equal amounts of protein per lane onto an SDS-polyacrylamide gel.
  - Run the gel until the dye front reaches the bottom.
- Protein Transfer:

- Transfer proteins from the gel to a PVDF or nitrocellulose membrane using a wet or semi-dry transfer system.
- Blocking:
  - Block the membrane with 5% non-fat dry milk or BSA in TBST (Tris-buffered saline with 0.1% Tween-20) for 1 hour at room temperature.
- Primary Antibody Incubation:
  - Incubate the membrane with anti-NRP-1 primary antibody diluted in blocking buffer overnight at 4°C with gentle agitation.
- Secondary Antibody Incubation:
  - Wash the membrane with TBST (3 x 10 minutes).
  - Incubate with an HRP-conjugated secondary antibody diluted in blocking buffer for 1 hour at room temperature.
- Detection:
  - Wash the membrane with TBST (3 x 10 minutes).
  - Incubate the membrane with an enhanced chemiluminescence (ECL) substrate.
  - Detect the signal using an imaging system.

## Flow Cytometry Protocol for NRP-1

- Cell Preparation:
  - Prepare a single-cell suspension from cultured cells or tissues.
  - Wash cells with FACS buffer (e.g., PBS with 2% FBS).
  - Count cells and adjust the concentration to  $1 \times 10^6$  cells/mL.
- Fc Receptor Blocking:

- Incubate cells with an Fc block reagent for 10-15 minutes at 4°C to prevent non-specific antibody binding.
- Primary Antibody Staining:
  - Add the fluorochrome-conjugated anti-NRP-1 antibody or a primary unconjugated antibody to the cells.
  - Incubate for 30-60 minutes at 4°C in the dark.
  - (If using an unconjugated primary) Wash cells and incubate with a fluorochrome-conjugated secondary antibody for 30 minutes at 4°C in the dark.
- Washing:
  - Wash cells twice with FACS buffer.
- Viability Staining (Optional but Recommended):
  - Resuspend cells in FACS buffer containing a viability dye (e.g., DAPI, Propidium Iodide, or a fixable viability stain).
- Data Acquisition:
  - Acquire data on a flow cytometer.
  - Include appropriate controls: unstained cells, isotype controls, and compensation controls.

## Visualizations

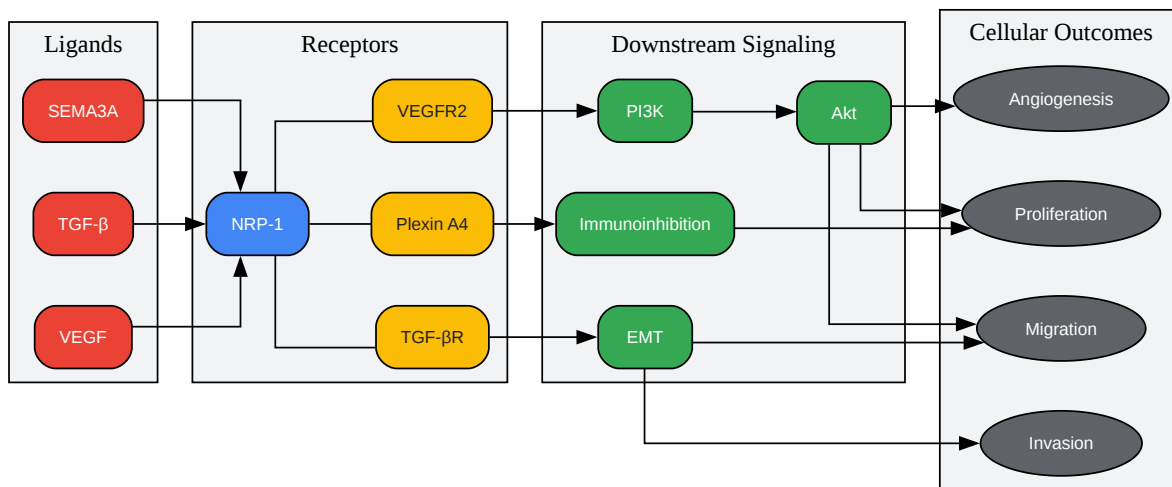

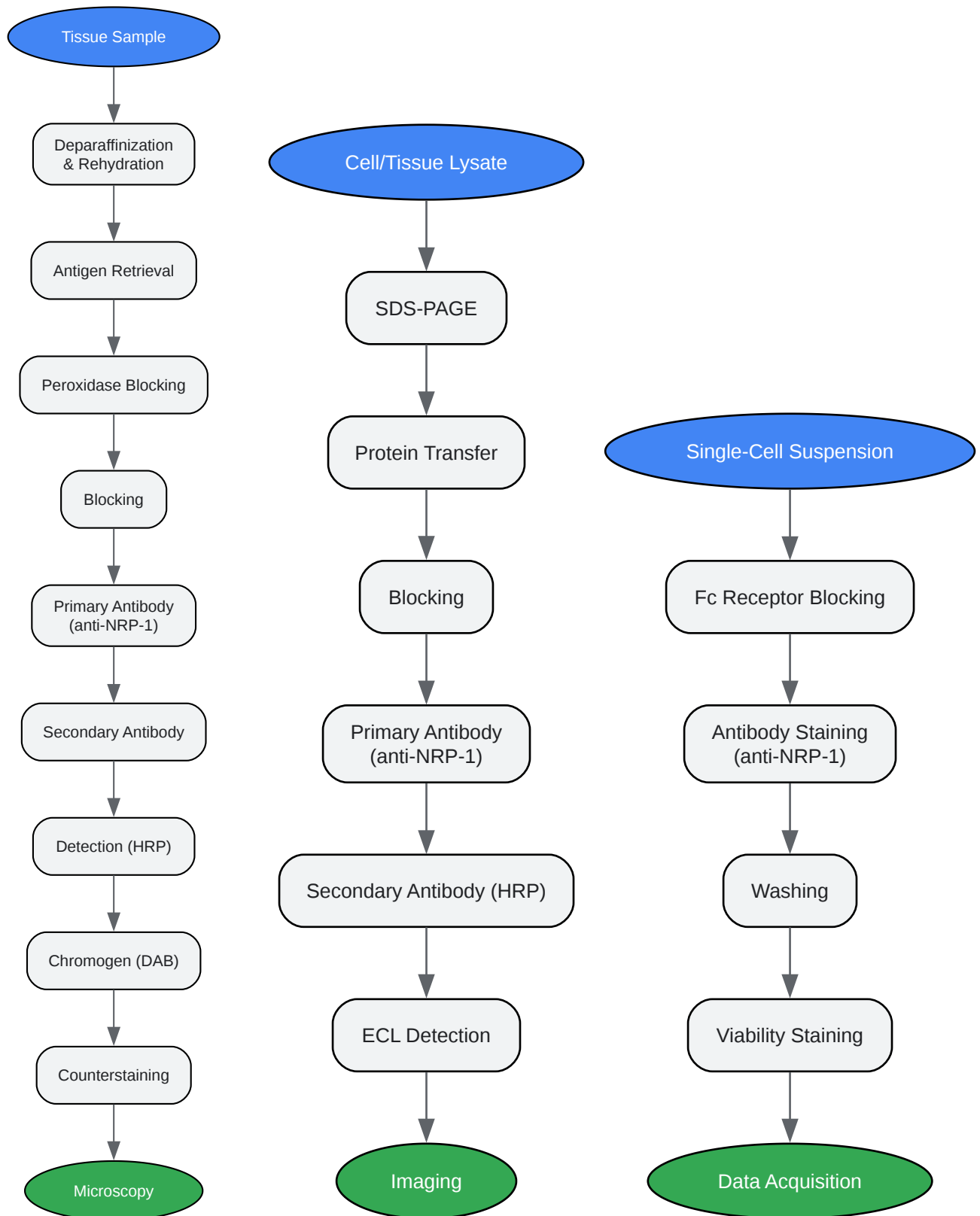

[Click to download full resolution via product page](#)

### Need Custom Synthesis?

BenchChem offers custom synthesis for rare earth carbides and specific isotopic labeling.

Email: [info@benchchem.com](mailto:info@benchchem.com) or [Request Quote Online](#).

## References

- [1. mayoclinic.elsevierpure.com](https://www.mayoclinic.elsevierpure.com) [[mayoclinic.elsevierpure.com](https://www.mayoclinic.elsevierpure.com)]
- [2. Neuropilin-1: A Multifaceted Target for Cancer Therapy - PMC](https://pubmed.ncbi.nlm.nih.gov/) [[pmc.ncbi.nlm.nih.gov](https://pubmed.ncbi.nlm.nih.gov/)]
- [3. researchgate.net](https://www.researchgate.net) [[researchgate.net](https://www.researchgate.net)]
- [4. aacrjournals.org](https://www.aacrjournals.org) [[aacrjournals.org](https://www.aacrjournals.org)]
- [5. Frontiers | Neuropilin-1: A Key Protein to Consider in the Progression of Pediatric Brain Tumors](https://www.frontiersin.org) [[frontiersin.org](https://www.frontiersin.org)]
- [6. youtube.com](https://www.youtube.com) [[youtube.com](https://www.youtube.com)]
- [7. qedbio.com](https://www.qedbio.com) [[qedbio.com](https://www.qedbio.com)]
- [8. ウェスタンブロットティング トラブルシューティング | Thermo Fisher Scientific - JP](https://www.thermofisher.com) [[thermofisher.com](https://www.thermofisher.com)]
- [9. origene.com](https://www.origene.com) [[origene.com](https://www.origene.com)]
- [10. Immunohistochemistry \(IHC\) Troubleshooting Guide & the Importance of Using Controls | Cell Signaling Technology](https://www.cellsignal.com) [[cellsignal.com](https://www.cellsignal.com)]
- [11. Western Blot Troubleshooting: 10 Common Problems and Solutions](https://www.synapse.patsnap.com) [[synapse.patsnap.com](https://www.synapse.patsnap.com)]
- [12. Western Blot Troubleshooting: Weak/No Signal & Other | Proteintech Group](https://www.ptglab.com) [[ptglab.com](https://www.ptglab.com)]
- [13. Western blot troubleshooting guide!](https://www.jacksonimmuno.com) [[jacksonimmuno.com](https://www.jacksonimmuno.com)]
- [14. Flow Cytometry Protocol & Troubleshooting - Creative Biolabs](https://www.creativebiolabs.net) [[creativebiolabs.net](https://www.creativebiolabs.net)]
- [15. bosterbio.com](https://www.bosterbio.com) [[bosterbio.com](https://www.bosterbio.com)]
- [16. biocompare.com](https://www.biocompare.com) [[biocompare.com](https://www.biocompare.com)]
- [17. antibody-creativebiolabs.com](https://www.antibody-creativebiolabs.com) [[antibody-creativebiolabs.com](https://www.antibody-creativebiolabs.com)]
- [18. Differential neuropilin isoform expressions highlight plasticity in macrophages in the heterogenous TME through in-silico profiling - PMC](https://pubmed.ncbi.nlm.nih.gov/) [[pmc.ncbi.nlm.nih.gov](https://pubmed.ncbi.nlm.nih.gov/)]
- [19. Expression of NRP-1 and NRP-2 in Endometrial Cancer - PMC](https://pubmed.ncbi.nlm.nih.gov/) [[pmc.ncbi.nlm.nih.gov](https://pubmed.ncbi.nlm.nih.gov/)]

- [20. NRP1-positive lung cancer cells possess tumor-initiating properties - PMC](#)  
[pmc.ncbi.nlm.nih.gov]
- To cite this document: BenchChem. [Technical Support Center: Addressing Variability in NRP-1 Expression in Tumors]. BenchChem, [2026]. [Online PDF]. Available at: [https://www.benchchem.com/product/b10799724/docs#technical-support-center-addressing-variability-in-nrp-1-expression-in-tumors]

---

### Disclaimer & Data Validity:

The information provided in this document is for Research Use Only (RUO) and is strictly not intended for diagnostic or therapeutic procedures. While BenchChem strives to provide accurate protocols, we make no warranties, express or implied, regarding the fitness of this product for every specific experimental setup.

**Technical Support:** The protocols provided are for reference purposes. Unsure if this reagent suits your experiment?

**Need Industrial/Bulk Grade?** [Request Custom Synthesis Quote](#)

## BenchChem

Our mission is to be the trusted global source of essential and advanced chemicals, empowering scientists and researchers to drive progress in science and industry.

### Contact

Address: 3281 E Guasti Rd  
Ontario, CA 91761, United States  
Phone: (601) 213-4426  
Email: [info@benchchem.com](mailto:info@benchchem.com)

[Contact our Ph.D. Support Team for a compatibility check](#)