

Application Notes and Protocols for UNC2025 Sensitivity Screening

Author: BenchChem Technical Support Team. **Date:** April 2026

Compound of Interest

Compound Name: *UNC2025*
Cat. No.: *B10799184*

[Get Quote](#)

For Researchers, Scientists, and Drug Development Professionals

Introduction

UNC2025 is a potent and orally bioavailable small-molecule dual inhibitor of MER and FMS-like tyrosine kinase 3 (FLT3).[1][2][3][4] Both MER and FLT3 are receptor tyrosine kinases that, when aberrantly activated, can drive the proliferation and survival of malignant cells, particularly in acute leukemias.[3][5] **UNC2025** competitively binds to the ATP-binding pocket of these kinases, inhibiting their phosphorylation and subsequent activation of downstream pro-survival signaling pathways.[2][4] This targeted inhibition leads to apoptosis and a reduction in tumor cell proliferation.[1][6] These application notes provide detailed protocols for assessing the sensitivity of cancer cell lines to **UNC2025**, both as a single agent and in combination with other therapies.

Mechanism of Action: MER and FLT3 Signaling

MER and FLT3 are key players in cell signaling pathways that regulate cell survival, proliferation, and differentiation. Their dysregulation is implicated in various cancers. **UNC2025**'s dual inhibitory action blocks these critical pathways.

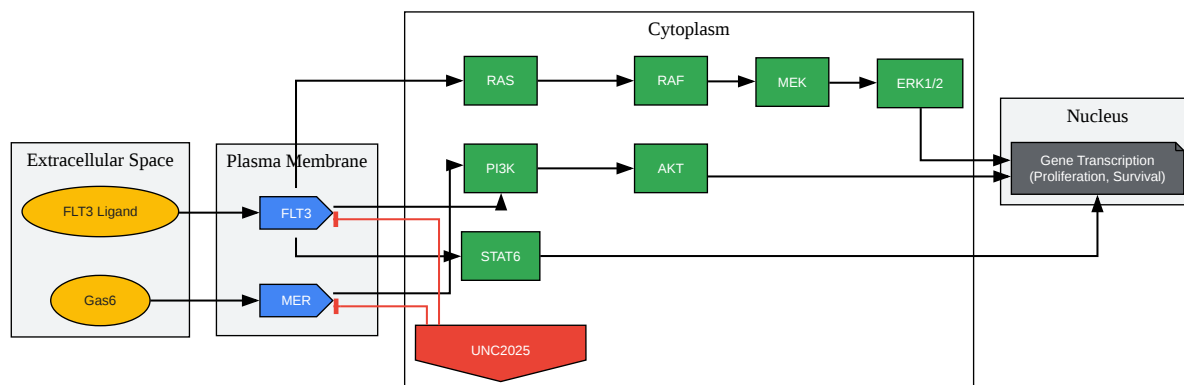

[Click to download full resolution via product page](#)

MER and FLT3 Signaling Pathways

Data Presentation

Quantitative data from sensitivity and synergy screens should be summarized for clear comparison.

Table 1: Single-Agent **UNC2025** Sensitivity (IC50 Values)

Cell Line	Cancer Type	MER Status	FLT3 Status	UNC2025 IC50 (nM)
697	B-ALL	Expressed	WT	2.7
Kasumi-1	AML	Expressed	WT	Data not available
Molm-14	AML	Expressed	ITD	14
User-defined 1				
User-defined 2				

IC50 values represent the concentration of **UNC2025** required to inhibit cell viability by 50%. Data for 697 and Molm-14 cells are from published studies.[3][5]

Table 2: Apoptosis Induction by **UNC2025**

Cell Line	UNC2025 Conc. (nM)	Treatment Time (hr)	% Apoptotic Cells (Annexin V+)	Fold Increase in Caspase-3/7 Activity
697	100	48	User-defined	User-defined
Molm-14	100	48	User-defined	User-defined
User-defined 1				
User-defined 2				

Table 3: Synergy Analysis of **UNC2025** with a Combination Agent

Cell Line	Combination Agent	UNC2025 IC50 (nM)	Agent IC50 (µM)	Combination Index (CI) at ED50	Interpretation
697	Methotrexate	User-defined	User-defined	User-defined	User-defined
User-defined					
1					
User-defined					
2					

CI < 1 indicates synergy, CI = 1 indicates an additive effect, and CI > 1 indicates antagonism.

Experimental Protocols

The following are detailed protocols for key assays in **UNC2025** sensitivity screening.

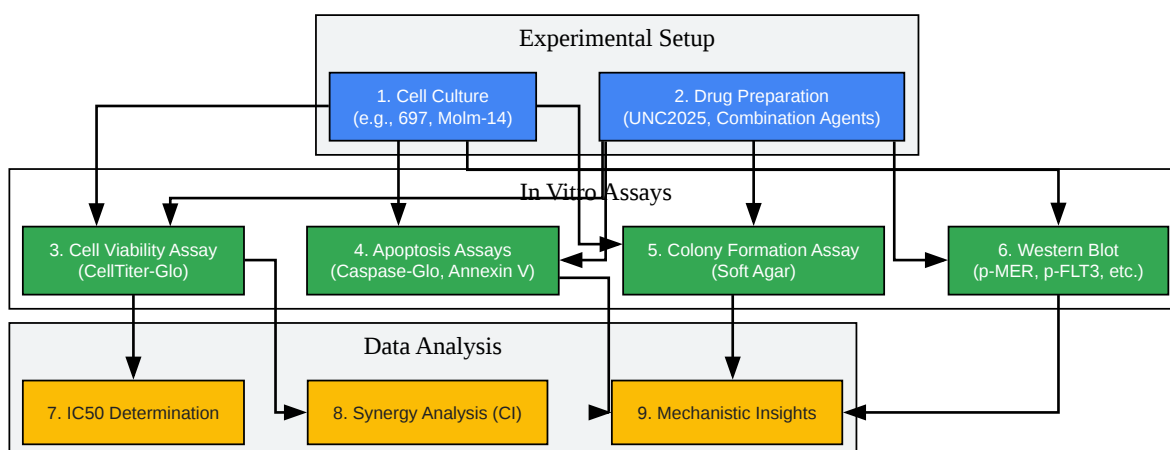

[Click to download full resolution via product page](#)

UNC2025 Sensitivity Screening Workflow

Protocol 1: Cell Viability Assay (CellTiter-Glo®)

This assay determines the number of viable cells in culture based on the quantification of ATP, an indicator of metabolically active cells.

Materials:

- **UNC2025**
- Cell line of interest
- Complete culture medium
- Opaque-walled 96-well plates
- CellTiter-Glo® Luminescent Cell Viability Assay kit
- Luminometer

Procedure:

- Seed cells in a 96-well opaque-walled plate at a predetermined optimal density in 100 µL of culture medium.
- Incubate the plate for 24 hours at 37°C in a humidified incubator with 5% CO₂.
- Prepare a serial dilution of **UNC2025** in culture medium.
- Add 100 µL of the **UNC2025** dilutions to the appropriate wells. Include vehicle-only (DMSO) control wells.
- Incubate for 72 hours at 37°C and 5% CO₂.
- Equilibrate the plate to room temperature for approximately 30 minutes.
- Prepare the CellTiter-Glo® reagent according to the manufacturer's instructions.
- Add 100 µL of the CellTiter-Glo® reagent to each well.

- Mix the contents on an orbital shaker for 2 minutes to induce cell lysis.
- Incubate at room temperature for 10 minutes to stabilize the luminescent signal.
- Measure luminescence using a plate-reading luminometer.

Data Analysis:

- Calculate the percentage of cell viability relative to the vehicle control.
- Plot the percentage of viability against the log of the **UNC2025** concentration.
- Determine the IC50 value using a non-linear regression curve fit (e.g., four-parameter logistic model).

Protocol 2: Apoptosis Assay (Caspase-Glo® 3/7)

This assay measures the activity of caspases 3 and 7, key biomarkers of apoptosis.

Materials:

- **UNC2025**
- Cell line of interest
- Complete culture medium
- White-walled 96-well plates
- Caspase-Glo® 3/7 Assay kit
- Luminometer

Procedure:

- Seed cells in a 96-well white-walled plate in 100 µL of culture medium.
- Treat cells with **UNC2025** at the desired concentrations (e.g., 1x and 5x IC50) and a vehicle control.

- Incubate for the desired time (e.g., 24, 48 hours) at 37°C and 5% CO₂.
- Equilibrate the plate to room temperature for approximately 30 minutes.
- Prepare the Caspase-Glo® 3/7 reagent according to the manufacturer's instructions.
- Add 100 µL of the Caspase-Glo® 3/7 reagent to each well.
- Mix the contents on a plate shaker at 300-500 rpm for 30 seconds.
- Incubate at room temperature for 1 to 3 hours.
- Measure luminescence using a plate-reading luminometer.

Data Analysis:

- Calculate the fold change in caspase activity relative to the vehicle control.

Protocol 3: Apoptosis Assay (Annexin V-FITC/PI Staining)

This flow cytometry-based assay differentiates between viable, early apoptotic, late apoptotic, and necrotic cells.

Materials:

- **UNC2025**
- Cell line of interest
- Complete culture medium
- Annexin V-FITC Apoptosis Detection Kit
- Propidium Iodide (PI)
- Binding Buffer
- Flow cytometer

Procedure:

- Seed cells and treat with **UNC2025** as described in the Caspase-Glo® assay.
- Harvest cells (including supernatant for suspension cells) and wash with cold PBS.
- Resuspend the cell pellet in 1X Binding Buffer at a concentration of 1×10^6 cells/mL.
- Transfer 100 μ L of the cell suspension to a flow cytometry tube.
- Add 5 μ L of Annexin V-FITC and 5 μ L of PI.
- Gently vortex and incubate for 15 minutes at room temperature in the dark.
- Add 400 μ L of 1X Binding Buffer to each tube.
- Analyze the samples by flow cytometry within one hour.

Data Analysis:

- Quantify the percentage of cells in each quadrant:
 - Annexin V- / PI- (viable)
 - Annexin V+ / PI- (early apoptotic)
 - Annexin V+ / PI+ (late apoptotic/necrotic)
 - Annexin V- / PI+ (necrotic)

Protocol 4: Colony Formation Assay (Soft Agar)

This assay assesses the ability of single cells to undergo anchorage-independent growth, a hallmark of cancer.

Materials:

- **UNC2025**

- Cell line of interest
- Complete culture medium
- Agar
- 6-well plates

Procedure:

- Bottom Agar Layer: Prepare a 0.6% agar solution in complete culture medium. Add 1.5 mL to each well of a 6-well plate and allow it to solidify.
- Top Agar Layer: Prepare a single-cell suspension of the cells in complete culture medium. Mix the cell suspension with a 0.3% agar solution (kept at 40°C) containing the desired concentration of **UNC2025** or vehicle.
- Plate 1.5 mL of the cell/agar mixture on top of the solidified bottom layer.
- Allow the top layer to solidify at room temperature.
- Add 1 mL of complete culture medium containing the appropriate concentration of **UNC2025** or vehicle to each well.
- Incubate at 37°C and 5% CO₂ for 2-3 weeks, feeding the cells with fresh medium containing the drug every 3-4 days.
- Stain the colonies with crystal violet and count them using a microscope.

Data Analysis:

- Calculate the percentage of colony formation inhibition relative to the vehicle control.

Protocol 5: Western Blot for Phosphorylated Proteins

This protocol is for detecting the phosphorylation status of MER, FLT3, and their downstream targets.

Materials:

- **UNC2025**

- Cell line of interest
- Lysis buffer with protease and phosphatase inhibitors
- Primary antibodies (e.g., p-MER, MER, p-FLT3, FLT3, p-AKT, AKT, p-ERK1/2, ERK1/2, p-STAT6, STAT6)
- HRP-conjugated secondary antibodies
- Chemiluminescent substrate
- Protein electrophoresis and blotting equipment

Procedure:

- Seed cells and allow them to adhere or grow to a suitable density.
- Treat the cells with **UNC2025** at various concentrations for a short duration (e.g., 1-4 hours).
- Lyse the cells in lysis buffer.
- Determine the protein concentration of the lysates.
- Separate the proteins by SDS-PAGE and transfer them to a PVDF membrane.
- Block the membrane and incubate with the primary antibody overnight at 4°C.
- Wash the membrane and incubate with the HRP-conjugated secondary antibody.
- Detect the signal using a chemiluminescent substrate and an imaging system.

Data Analysis:

- Qualitatively assess the decrease in the phosphorylated form of the target proteins with increasing concentrations of **UNC2025**. Densitometry can be used for semi-quantitative analysis.

Protocol 6: Synergy Analysis

This involves treating cells with **UNC2025** and another agent in combination to determine if their combined effect is synergistic, additive, or antagonistic.

Procedure:

- Determine the IC50 value for each drug individually using the CellTiter-Glo® assay.
- Design a combination matrix with varying concentrations of **UNC2025** and the other agent, often at a constant ratio based on their IC50 values.
- Perform the CellTiter-Glo® assay with the drug combinations.
- Calculate the Combination Index (CI) using software such as CompuSyn.

Data Analysis:

- $CI < 1$: Synergism
- $CI = 1$: Additive effect
- $CI > 1$: Antagonism

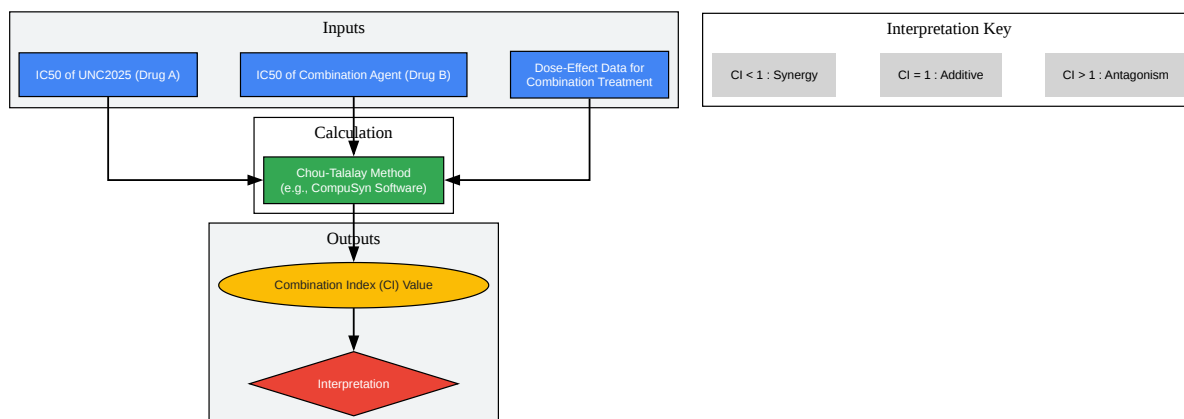

[Click to download full resolution via product page](#)

Logic for Synergy Analysis

Need Custom Synthesis?

BenchChem offers custom synthesis for rare earth carbides and specific isotopic labeling.

Email: info@benchchem.com or [Request Quote Online](#).

References

- [1. CellTiter-Glo® Luminescent Cell Viability Assay Protocol \[promega.jp\]](#)
- [2. artscimedia.case.edu \[artscimedia.case.edu\]](#)
- [3. Annexin V and PI Staining Protocol for Apoptosis by Flow Cytometry | Bio-Techne \[bio-techne.com\]](#)

- [4. Annexin V staining assay protocol for apoptosis | Abcam \[abcam.com\]](#)
- [5. Star Republic: Guide for Biologists \[sciencegateway.org\]](#)
- [6. millerlaboratory.org \[millerlaboratory.org\]](#)
- To cite this document: BenchChem. [Application Notes and Protocols for UNC2025 Sensitivity Screening]. BenchChem, [2026]. [Online PDF]. Available at: [\[https://www.benchchem.com/product/b10799184/docs#application-notes-and-protocols-for-unc2025-sensitivity-screening\]](https://www.benchchem.com/product/b10799184/docs#application-notes-and-protocols-for-unc2025-sensitivity-screening)

Disclaimer & Data Validity:

The information provided in this document is for Research Use Only (RUO) and is strictly not intended for diagnostic or therapeutic procedures. While BenchChem strives to provide accurate protocols, we make no warranties, express or implied, regarding the fitness of this product for every specific experimental setup.

Technical Support: The protocols provided are for reference purposes. Unsure if this reagent suits your experiment?

Need Industrial/Bulk Grade? [Request Custom Synthesis Quote](#)

BenchChem

Our mission is to be the trusted global source of essential and advanced chemicals, empowering scientists and researchers to drive progress in science and industry.

Contact

Address: 3281 E Guasti Rd
Ontario, CA 91761, United States
Phone: (601) 213-4426
Email: info@benchchem.com

[Contact our Ph.D. Support Team for a compatibility check](#)

