

# Application Notes and Protocols for PZ-1190

## Administration in Mouse Studies

**Author:** BenchChem Technical Support Team. **Date:** April 2026

### Compound of Interest

Compound Name: PZ-1190  
Cat. No.: B10799408

[Get Quote](#)

For Researchers, Scientists, and Drug Development Professionals

These application notes provide a comprehensive overview of the administration of **PZ-1190**, a multi-target serotonin and dopamine receptor ligand with potential antipsychotic properties, for in vivo studies in mice. The following protocols are based on established methodologies for evaluating novel antipsychotic agents in rodent models.

## Mechanism of Action

**PZ-1190** is a novel compound that demonstrates potent antagonistic activity at dopamine D<sub>2</sub> and serotonin 5-HT<sub>2a</sub> receptors, along with partial agonistic activity at serotonin 5-HT<sub>1a</sub> receptors. This multi-receptor profile is characteristic of atypical antipsychotics, suggesting potential efficacy against both positive and negative symptoms of schizophrenia with a lower risk of extrapyramidal side effects.

A diagram illustrating the proposed signaling pathway of **PZ-1190** is provided below.

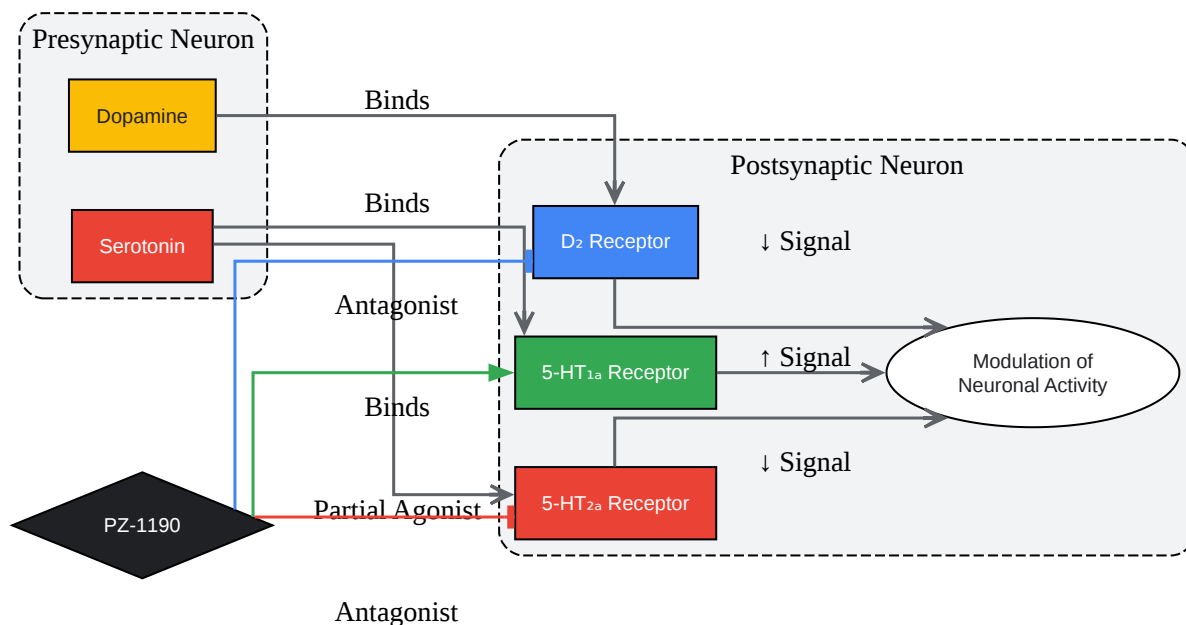

[Click to download full resolution via product page](#)

Caption: Proposed mechanism of action of **PZ-1190**.

## Quantitative Data Summary

The following table summarizes typical dosage ranges and administration routes for antipsychotic drug candidates in mouse models, which can be adapted for **PZ-1190** studies.

Parameter	Route of Administration	Dosage Range (mg/kg)	Frequency	Vehicle
Behavioral Screening	Intraperitoneal (i.p.)	1 - 10	Single dose	0.9% Saline with 1% Tween 80
Oral (p.o.)	5 - 20	Single dose	0.5% Methylcellulose in water	
Chronic Studies	Subcutaneous (s.c.)	1 - 5	Once or twice daily	Sesame oil or other suitable vehicle
Oral (p.o. via gavage)	5 - 20	Once daily	0.5% Methylcellulose in water	

## Experimental Protocols

Detailed methodologies for key experiments to evaluate the antipsychotic potential of **PZ-1190** in mice are provided below.

### Protocol 1: Evaluation of Antipsychotic-like Activity in the MK-801-Induced Hyperlocomotion Model

This model is widely used to screen for antipsychotic potential by assessing a compound's ability to reverse the psychostimulant-induced increase in locomotor activity.

Materials:

- **PZ-1190**
- MK-801 (Dizocilpine)
- Vehicle (e.g., 0.9% Saline with 1% Tween 80)
- Male C57BL/6 mice (8-10 weeks old)

- Open field activity chambers equipped with infrared beams

Procedure:

- Habituation: Acclimate mice to the testing room for at least 1 hour before the experiment. Place each mouse in an individual open field chamber for a 30-minute habituation period.
- Drug Administration:
  - Administer **PZ-1190** (e.g., 1, 3, or 10 mg/kg, i.p.) or vehicle to different groups of mice.
  - 30 minutes after **PZ-1190** or vehicle administration, administer MK-801 (0.2 mg/kg, i.p.) to all mice except the control group, which receives a second vehicle injection.
- Data Collection: Immediately after the MK-801 injection, place the mice back into the open field chambers and record locomotor activity (e.g., total distance traveled, number of beam breaks) for 60-90 minutes.
- Data Analysis: Analyze the data using a one-way ANOVA followed by a post-hoc test (e.g., Dunnett's or Tukey's) to compare the locomotor activity of the **PZ-1190**-treated groups to the MK-801 control group.

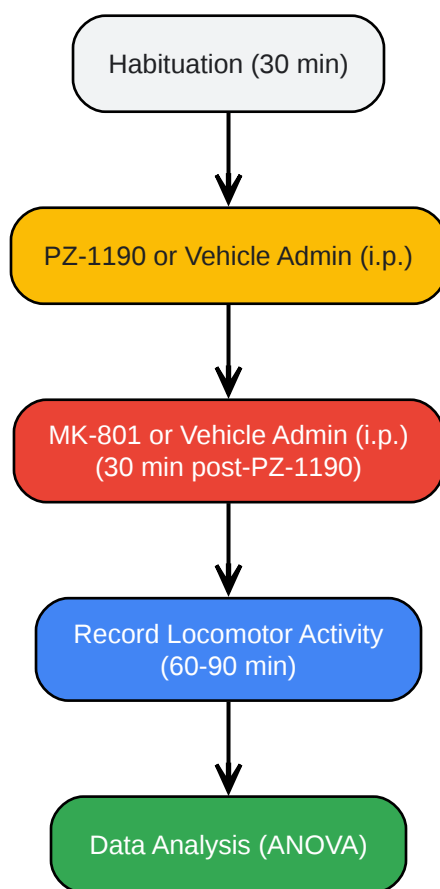

[Click to download full resolution via product page](#)

Caption: Workflow for the MK-801-induced hyperlocomotion test.

## Protocol 2: Assessment of Extrapyramidal Side Effects using the Catalepsy Test

This test is used to evaluate the potential of a compound to induce catalepsy, a common side effect of typical antipsychotics.

Materials:

- **PZ-1190**
- Haloperidol (positive control)
- Vehicle

- Male C57BL/6 mice (8-10 weeks old)
- A horizontal bar raised 5 cm from the surface

#### Procedure:

- Drug Administration: Administer **PZ-1190** (at doses effective in the hyperlocomotion test), haloperidol (e.g., 1 mg/kg, i.p.), or vehicle to different groups of mice.
- Catalepsy Assessment: At 30, 60, and 90 minutes post-injection, gently place the forepaws of each mouse on the horizontal bar.
- Data Collection: Measure the time (in seconds) it takes for the mouse to remove both forepaws from the bar. A cut-off time of 180 seconds is typically used.
- Data Analysis: Analyze the data using a repeated-measures ANOVA or a Kruskal-Wallis test to compare the latency to descend between the treatment groups at each time point.

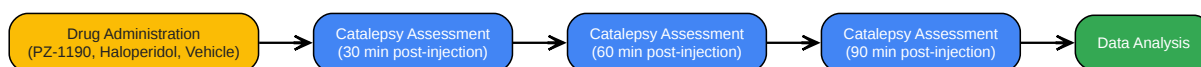

[Click to download full resolution via product page](#)

Caption: Workflow for the catalepsy test.

## General Considerations for Administration

- Formulation: **PZ-1190** should be dissolved in a suitable vehicle. For intraperitoneal injections, a solution in 0.9% saline containing a small amount of a solubilizing agent like Tween 80 is common. For oral administration, a suspension in 0.5% methylcellulose is often used.
- Volume: The injection volume should be appropriate for the size of the mouse and the route of administration. Typically, for intraperitoneal injections, a volume of 10 ml/kg is used. For oral gavage, the volume should not exceed 10 ml/kg.

- **Animal Welfare:** All animal procedures should be performed in accordance with institutional and national guidelines for the care and use of laboratory animals.

By following these protocols, researchers can effectively evaluate the in vivo antipsychotic potential and side effect profile of **PZ-1190** in mouse models. Careful consideration of the experimental design, including appropriate controls and statistical analysis, is crucial for obtaining reliable and reproducible results.

- **To cite this document:** BenchChem. [Application Notes and Protocols for PZ-1190 Administration in Mouse Studies]. BenchChem, [2026]. [Online PDF]. Available at: [<https://www.benchchem.com/product/b10799408/docs#application-notes-and-protocols-for-pz-1190-administration-in-mouse-studies>]

---

#### Disclaimer & Data Validity:

The information provided in this document is for Research Use Only (RUO) and is strictly not intended for diagnostic or therapeutic procedures. While BenchChem strives to provide accurate protocols, we make no warranties, express or implied, regarding the fitness of this product for every specific experimental setup.

**Technical Support:** The protocols provided are for reference purposes. Unsure if this reagent suits your experiment?

**Need Industrial/Bulk Grade?** [Request Custom Synthesis Quote](#)

## BenchChem

Our mission is to be the trusted global source of essential and advanced chemicals, empowering scientists and researchers to drive progress in science and industry.

#### Contact

Address: 3281 E Guasti Rd  
Ontario, CA 91761, United States  
Phone: (601) 213-4426  
Email: [info@benchchem.com](mailto:info@benchchem.com)

Contact our Ph.D. Support Team for a compatibility check