

Troubleshooting inconsistent LDC4297 hydrochloride results

Author: BenchChem Technical Support Team. **Date:** April 2026

Compound of Interest

Compound Name: LDC4297 hydrochloride

Cat. No.: B10798903

[Get Quote](#)

Technical Support Center: LDC4297 Hydrochloride

This technical support center provides troubleshooting guides and frequently asked questions (FAQs) to help researchers, scientists, and drug development professionals address common issues encountered during experiments with **LDC4297 hydrochloride**.

Frequently Asked Questions (FAQs)

Q1: What is the mechanism of action of **LDC4297 hydrochloride**?

A1: **LDC4297 hydrochloride** is a potent and selective inhibitor of Cyclin-Dependent Kinase 7 (CDK7).[1][2] It functions in an ATP-competitive manner, binding to the ATP pocket of CDK7.[3] CDK7 is a crucial kinase involved in the regulation of both cell cycle progression and transcription.[2][4] By inhibiting CDK7, LDC4297 can block the phosphorylation of the carboxy-terminal domain (CTD) of RNA polymerase II, leading to an inhibition of transcription, and can also affect cell cycle progression.[4][5]

Q2: What are the primary research applications for **LDC4297 hydrochloride**?

A2: **LDC4297 hydrochloride** is primarily used in cancer and virology research. Studies have demonstrated its ability to reduce cell proliferation in various cancer cell lines, particularly pancreatic cancer.[4][6] It also exhibits broad-spectrum antiviral activity against several viruses, including human cytomegalovirus (HCMV), herpesviruses, adenoviruses, and others.[1][3][7]

Q3: How should I store and handle **LDC4297 hydrochloride**?

A3: For long-term storage, it is recommended to store the stock solution at -80°C for up to 6 months or at -20°C for up to 1 month.[7] For in vivo experiments, it is advisable to prepare the working solution fresh on the same day of use.[7] If precipitation occurs during the preparation of solutions, gentle heating and/or sonication can be used to aid dissolution.[7][8]

Q4: Is LDC4297 selective for CDK7?

A4: Yes, LDC4297 is highly selective for CDK7. Kinome-wide profiling has shown that at a concentration of 100 nM, it strongly inhibits CDK7 with minimal effects on a large panel of other kinases.[3][9] While it shows some activity against other CDKs like CDK2, CDK5, and CDK3 at higher concentrations, its affinity for CDK7 is significantly higher.[3][9]

Troubleshooting Guides

Issue 1: Inconsistent IC50/EC50 Values

You may observe significant variability in the half-maximal inhibitory concentration (IC50) or half-maximal effective concentration (EC50) of **LDC4297 hydrochloride** between experiments.

Potential Cause	Recommended Solution
Variable ATP Concentration	<p>LDC4297 is an ATP-competitive inhibitor.[3] Variations in intracellular ATP levels or in the ATP concentration of your in vitro kinase assay will directly impact the apparent IC50 value.</p> <p>Ensure consistent cell culture conditions (e.g., cell density, media freshness) to maintain stable intracellular ATP levels. For in vitro assays, use a fixed and clearly reported ATP concentration, ideally close to the Km for ATP of CDK7.</p>
Cell Line-Specific Differences	<p>Different cell lines can exhibit varying sensitivity to LDC4297.[6] This can be due to differences in the expression levels of CDK7, its binding partners, or downstream effectors. Always use the same cell line and passage number for comparable experiments. If you are comparing different cell lines, be aware that their intrinsic biology can lead to different IC50/EC50 values.</p>
Compound Degradation	<p>Improper storage of LDC4297 hydrochloride can lead to its degradation. Prepare fresh working solutions from a properly stored stock for each experiment. Avoid repeated freeze-thaw cycles of the stock solution.</p>
Assay-Dependent Variability	<p>The choice of experimental assay can influence the measured potency. For example, a cell viability assay might yield a different value than a direct kinase inhibition assay. Use the same assay conditions, including incubation time and readout method, for all related experiments.</p>

Issue 2: Unexpected or High Cytotoxicity

You may observe higher than expected cell death or signs of cytotoxicity, even at low concentrations of **LDC4297 hydrochloride**.

Potential Cause	Recommended Solution
Cell-Type Specific Sensitivity	Some cell lines are inherently more sensitive to CDK7 inhibition.[6] The cytotoxic concentration (CC50) can vary significantly between different cell types.[3] It is crucial to determine the CC50 for your specific cell line to establish a proper therapeutic window.
Off-Target Effects at High Concentrations	While LDC4297 is selective for CDK7, at very high concentrations, it may inhibit other kinases, leading to off-target effects and increased cytotoxicity.[9] Use the lowest effective concentration possible and perform dose-response experiments to identify the optimal concentration range.
Solvent Toxicity	The solvent used to dissolve LDC4297 hydrochloride (e.g., DMSO) can be toxic to cells at certain concentrations. Ensure that the final concentration of the solvent in your cell culture media is below the toxic threshold for your cells (typically <0.5% for DMSO). Always include a vehicle-only control in your experiments.

Issue 3: Variability in Western Blot Results for Downstream Targets

You may see inconsistent changes in the phosphorylation or expression levels of downstream targets of CDK7, such as RNA Polymerase II or Retinoblastoma protein (Rb).

Potential Cause	Recommended Solution
Timing of Analysis	The effects of LDC4297 on downstream signaling can be time-dependent. For example, changes in protein expression may take longer to become apparent than changes in phosphorylation status.[6][10] Perform a time-course experiment to determine the optimal time point for observing the desired effect on your target of interest.
Cell Cycle Synchronization	As CDK7 is a key regulator of the cell cycle, the cell cycle status of your cell population can influence the experimental outcome.[4] For more consistent results, consider synchronizing your cells before treatment with LDC4297.
Antibody Quality	Poor antibody quality or specificity can lead to unreliable western blot results. Validate your antibodies to ensure they are specific for the target protein and its phosphorylated form.
Loading Controls	Inconsistent protein loading can lead to misinterpretation of western blot data. Always use a reliable loading control (e.g., GAPDH, β -actin) to normalize your results.

Quantitative Data Summary

Table 1: In Vitro Kinase Inhibition by LDC4297

Kinase	IC50 (nM)
CDK7	0.13[1]

Table 2: Antiviral Activity of **LDC4297 Hydrochloride**

Virus	Cell Line	EC50
Human Cytomegalovirus (HCMV)	HFF	24.5 nM[1][3]
Guinea Pig Cytomegalovirus (GPCMV)	0.05 μ M[7]	
Murine Cytomegalovirus (MCMV)	0.07 μ M[7]	
Human Herpesvirus 6A (HHV-6A)	0.04 μ M[7]	
Herpes Simplex Virus 1 (HSV-1)	0.02 μ M[7]	
Herpes Simplex Virus 2 (HSV-2)	0.27 μ M[7]	
Varicella-Zoster Virus (VZV)	0.06 μ M[7]	
Epstein-Barr Virus (EBV)	1.21 μ M[7]	
Human Adenovirus 2 (HAdV-2)	0.25 μ M[7]	
Vaccinia Virus	0.77 μ M[7]	
HIV-1 (NL4-3)	1.04 μ M[7]	
HIV-1 (4LIG7)	1.13 μ M[7]	
Influenza A Virus	0.99 μ M[7]	

Table 3: Anti-proliferative Activity of LDC4297

Cell Line	GI50 (μM)
Human Foreskin Fibroblasts (HFF)	4.5[7][10]
Pancreatic Cancer Cell Lines (Panc89, PT45, BxPc3)	Effective at 0.05[6]
Pancreatic Cancer Cell Line (Mia-Paca2)	Intermediate sensitivity[6]
Pancreatic Cancer Cell Lines (Panc1, Capan1, Capan2, AsPc1, A8184)	Less sensitive[6]

Experimental Protocols

Cell Viability Assay (e.g., CellTiter-Glo®)

- Seed cells in a 96-well plate at a predetermined density (e.g., 300–1000 cells/well) and allow them to adhere for 24 hours.[6]
- Prepare a serial dilution of **LDC4297 hydrochloride** in the appropriate cell culture medium.
- Remove the old medium from the cells and add the medium containing different concentrations of LDC4297. Include a vehicle-only control.
- Incubate the plate for the desired time period (e.g., 4 days).[6]
- Add CellTiter-Glo® Reagent to each well according to the manufacturer's instructions.[6]
- Measure luminescence using a plate reader.[6]
- Calculate cell viability as a percentage of the vehicle-only control and plot the results to determine the GI50 value.

Western Blot Analysis

- Seed cells and treat with **LDC4297 hydrochloride** for the desired time and concentration.
- Lyse the cells in an appropriate lysis buffer containing protease and phosphatase inhibitors.

- Determine the protein concentration of the lysates using a standard method (e.g., BCA assay).
- Denature the protein samples by boiling in Laemmli buffer.
- Separate the proteins by SDS-PAGE and transfer them to a PVDF or nitrocellulose membrane.
- Block the membrane with a suitable blocking buffer (e.g., 5% non-fat milk or BSA in TBST) for 1 hour at room temperature.
- Incubate the membrane with the primary antibody overnight at 4°C.
- Wash the membrane with TBST and incubate with the appropriate HRP-conjugated secondary antibody for 1 hour at room temperature.
- Wash the membrane again with TBST.
- Detect the protein bands using an enhanced chemiluminescence (ECL) substrate and an imaging system.
- Quantify the band intensities and normalize to a loading control.

Visualizations

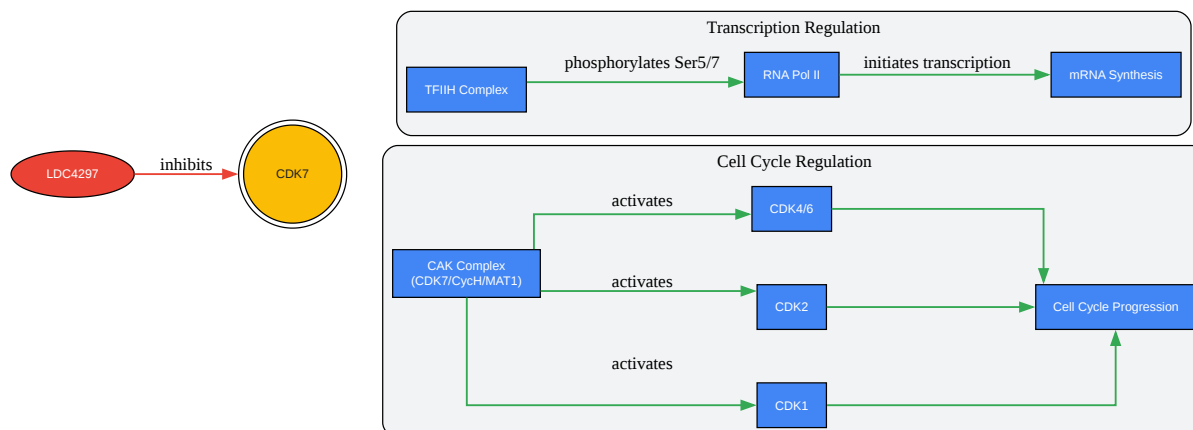

[Click to download full resolution via product page](#)

Caption: LDC4297 inhibits CDK7, a key component of TFIIH and CAK complexes.

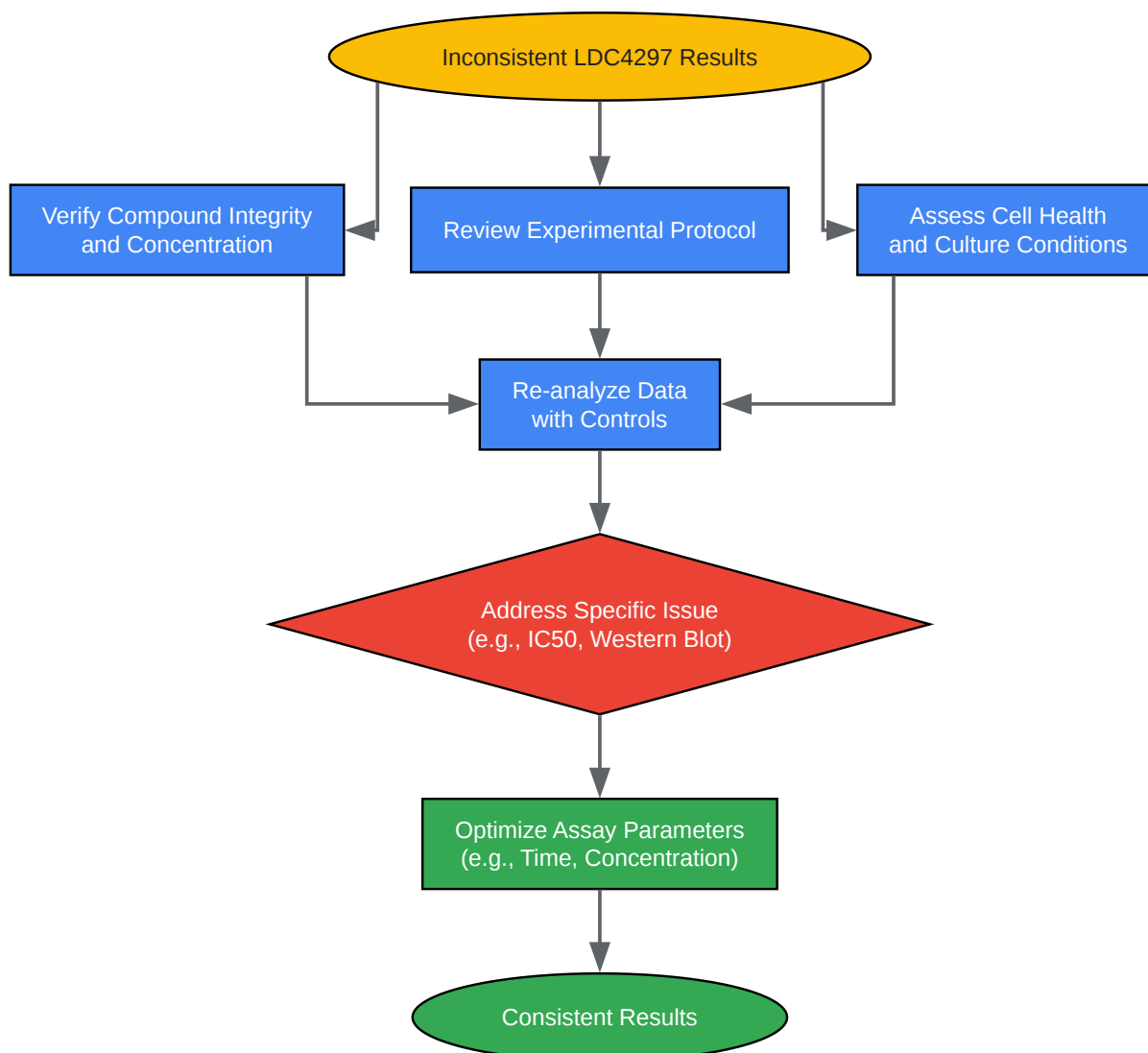

[Click to download full resolution via product page](#)

Caption: A systematic workflow for troubleshooting inconsistent LDC4297 results.

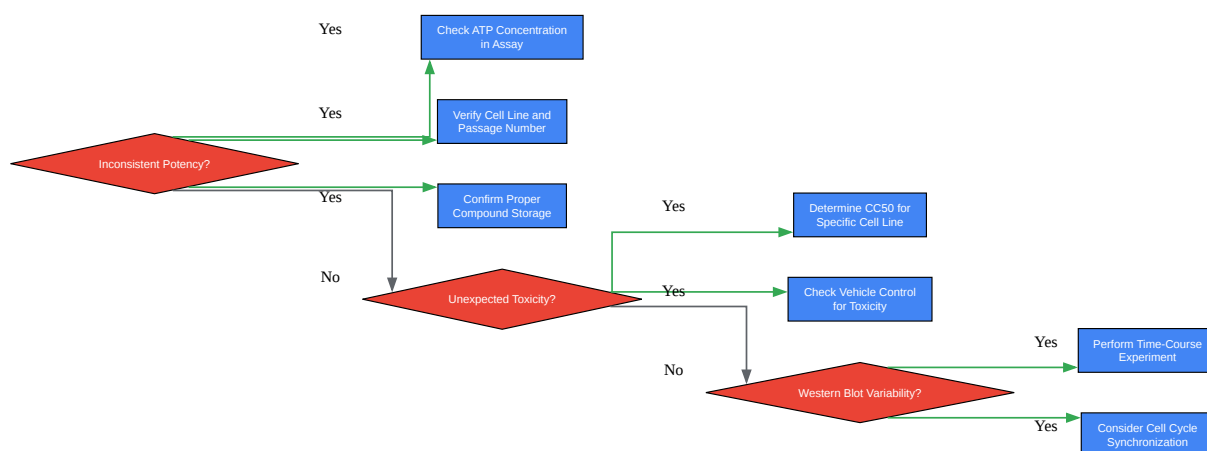

[Click to download full resolution via product page](#)

Caption: Decision-making logic for troubleshooting common LDC4297 issues.

Need Custom Synthesis?

BenchChem offers custom synthesis for rare earth carbides and specific isotopic labeling.

Email: info@benchchem.com or [Request Quote Online](#).

References

- 1. [medchemexpress.com](https://www.medchemexpress.com) [medchemexpress.com]
- 2. LDC-4297 - Drug Targets, Indications, Patents - Synapse [synapse.patsnap.com]

- [3. A Novel CDK7 Inhibitor of the Pyrazolotriazine Class Exerts Broad-Spectrum Antiviral Activity at Nanomolar Concentrations - PMC \[pmc.ncbi.nlm.nih.gov\]](#)
- [4. Control of Expression of Key Cell Cycle Enzymes Drives Cell Line-Specific Functions of CDK7 in Human PDAC Cells - PMC \[pmc.ncbi.nlm.nih.gov\]](#)
- [5. Cyclin-Dependent Kinase 7 Controls mRNA Synthesis by Affecting Stability of Preinitiation Complexes, Leading to Altered Gene Expression, Cell Cycle Progression, and Survival of Tumor Cells - PMC \[pmc.ncbi.nlm.nih.gov\]](#)
- [6. mdpi.com \[mdpi.com\]](#)
- [7. medchemexpress.com \[medchemexpress.com\]](#)
- [8. LDC4297 | CDK7 Inhibitor | AmBeed.com \[ambeed.com\]](#)
- [9. darkkinome.org \[darkkinome.org\]](#)
- [10. file.medchemexpress.com \[file.medchemexpress.com\]](#)
- To cite this document: BenchChem. [Troubleshooting inconsistent LDC4297 hydrochloride results]. BenchChem, [2026]. [Online PDF]. Available at: [<https://www.benchchem.com/product/b10798903/docs#troubleshooting-inconsistent-ldc4297-hydrochloride-results>]

Disclaimer & Data Validity:

The information provided in this document is for Research Use Only (RUO) and is strictly not intended for diagnostic or therapeutic procedures. While BenchChem strives to provide accurate protocols, we make no warranties, express or implied, regarding the fitness of this product for every specific experimental setup.

Technical Support: The protocols provided are for reference purposes. Unsure if this reagent suits your experiment?

Need Industrial/Bulk Grade? [Request Custom Synthesis Quote](#)

BenchChem

Our mission is to be the trusted global source of essential and advanced chemicals, empowering scientists and researchers to drive progress in science and industry.

Contact

Address: 3281 E Guasti Rd

Ontario, CA 91761, United States

Phone: (601) 213-4426

Email: info@benchchem.com

[Contact our Ph.D. Support Team for a compatibility check](#)