

Technical Support Center: Understanding and Troubleshooting Off-Target Effects of CC-90003

Author: BenchChem Technical Support Team. **Date:** April 2026

Compound of Interest

Compound Name: CC-90003

Cat. No.: B10798849

[Get Quote](#)

For Researchers, Scientists, and Drug Development Professionals

This technical support center provides guidance for researchers encountering unexpected results or seeking to understand the off-target effects of **CC-90003**, a potent and selective covalent inhibitor of ERK1/2. The information is presented in a question-and-answer format to directly address common issues and provide clear troubleshooting strategies.

Frequently Asked Questions (FAQs)

Q1: What is the primary mechanism of action of **CC-90003**?

A1: **CC-90003** is a covalent inhibitor of Extracellular signal-regulated kinases 1 and 2 (ERK1/2), which are key components of the Mitogen-Activated Protein Kinase (MAPK) signaling pathway.^{[1][2]} By irreversibly binding to ERK1/2, **CC-90003** blocks their kinase activity, thereby inhibiting downstream signaling that is often hyperactivated in various cancers and plays a crucial role in cell proliferation, differentiation, and survival.^{[1][2]}

Q2: I'm observing a phenotype in my cell line that is not consistent with ERK1/2 inhibition. Could this be an off-target effect?

A2: Yes, it is possible. While **CC-90003** is highly selective for ERK1/2, kinase inhibitor off-target activity can occur, especially at higher concentrations.[2] If the observed phenotype (e.g., unexpected levels of apoptosis, changes in cell morphology, or paradoxical pathway activation) does not correlate with the inhibition of known downstream targets of ERK1/2, it may be due to the inhibition of other kinases.

Q3: What are the known off-target kinases for **CC-90003**?

A3: Biochemical and cellular assays have identified three primary off-target kinases for **CC-90003**:[\[1\]](#)[\[2\]](#)

- KDR (Kinase Insert Domain Receptor), also known as VEGFR2
- FLT3 (FMS-like Tyrosine Kinase 3)
- PDGFR α (Platelet-Derived Growth Factor Receptor Alpha)

Significant inhibition of these kinases has been observed at a concentration of 1 μ mol/L of **CC-90003**.[\[1\]](#)[\[2\]](#)

Q4: Why was the clinical development of **CC-90003** discontinued?

A4: The clinical development of **CC-90003** was halted due to unanticipated neurotoxicity observed in a Phase Ia clinical trial.[\[3\]](#)[\[4\]](#)[\[5\]](#) This adverse effect is thought to be a result of a combination of on-target ERK inhibition and potential off-target activities.[\[4\]](#) This highlights the importance of carefully evaluating potential off-target effects in preclinical experiments.

Troubleshooting Guide

This guide provides structured approaches to investigate and mitigate potential off-target effects of **CC-90003** in your experiments.

Issue 1: Unexpected or Exaggerated Cytotoxicity

If you observe higher than expected cell death in your experiments, it could be due to the on-target effect on ERK1/2, off-target inhibition of kinases essential for cell survival, or a combination of both.

Troubleshooting Steps:

- Confirm On-Target ERK1/2 Inhibition:
 - Perform a Western blot to analyze the phosphorylation status of known ERK1/2 downstream targets, such as RSK (p90 ribosomal S6 kinase). A decrease in phosphorylated RSK (p-RSK) will confirm on-target activity.
- Perform a Dose-Response Analysis:
 - Treat your cells with a range of **CC-90003** concentrations. If the cytotoxic effect is only observed at concentrations significantly higher than those required to inhibit p-RSK, it may suggest an off-target effect.
- Use a Structurally Different ERK1/2 Inhibitor:
 - Compare the phenotype induced by **CC-90003** with that of another ERK1/2 inhibitor with a different chemical scaffold. If the unexpected cytotoxicity is unique to **CC-90003**, it strengthens the possibility of an off-target effect.

Issue 2: Phenotype Suggestive of KDR, FLT3, or PDGFR α Inhibition

If your experimental observations align with the known biological roles of the off-target kinases (e.g., effects on angiogenesis, hematopoiesis, or cell migration), it is prudent to investigate their inhibition directly.

Troubleshooting Steps:

- Assess the Activity of Off-Target Kinases:
 - Directly measure the kinase activity of KDR, FLT3, or PDGFR α in your experimental system. This can be achieved using commercially available kinase assay kits. Refer to the Experimental Protocols section below for detailed methodologies.
- Analyze Downstream Signaling of Off-Target Kinases:

- If direct kinase assays are not feasible, perform Western blots to assess the phosphorylation status of key downstream effectors of the off-target kinases.
 - KDR (VEGFR2): Analyze phosphorylation of PLC γ , AKT, and eNOS.
 - FLT3: Analyze phosphorylation of STAT5, AKT, and ERK (note the potential for confounding results with the on-target effect).[6][7]
 - PDGFR α : Analyze phosphorylation of AKT, STAT3, and PLC γ .

Quantitative Data Summary

The following table summarizes the known kinase inhibition profile of **CC-90003**.

Kinase Target	Type	Potency	Reference
ERK1/2	On-Target	IC ₅₀ in the 10-20 nM range	[2]
KDR (VEGFR2)	Off-Target	>80% inhibition at 1 μ mol/L	[1][2]
FLT3	Off-Target	>80% inhibition at 1 μ mol/L	[1][2]
PDGFR α	Off-Target	>80% inhibition at 1 μ mol/L	[1][2]

Experimental Protocols

The following are generalized protocols for commercially available luminescent kinase assays that can be adapted to test for off-target inhibition by **CC-90003**.

Protocol 1: KDR (VEGFR2) Kinase Activity Assay

This protocol is based on the principle of quantifying the amount of ATP remaining in solution following a kinase reaction using a luciferase-based system. A decrease in luminescence indicates higher kinase activity.

Materials:

- Recombinant KDR (VEGFR2) enzyme
- Kinase assay buffer
- ATP solution
- KDR substrate (e.g., Poly(Glu,Tyr) 4:1)
- **CC-90003** (or other test inhibitor)
- Kinase-Glo® Luminescent Kinase Assay Kit
- White, opaque 96-well plates
- Luminometer

Procedure:

- Prepare a master mix of kinase assay buffer, ATP, and KDR substrate.
- Add the test inhibitor (**CC-90003**) at various concentrations to the wells of the 96-well plate. Include a no-inhibitor control and a no-enzyme "blank" control.
- Add the recombinant KDR enzyme to all wells except the blank.
- Add the master mix to all wells to initiate the kinase reaction.
- Incubate the plate at 30°C for a specified time (e.g., 60 minutes).
- Allow the plate to equilibrate to room temperature.
- Add the Kinase-Glo® reagent to all wells to stop the reaction and generate a luminescent signal.
- Incubate at room temperature for 10 minutes to stabilize the signal.
- Measure luminescence using a luminometer.

- Calculate the percent inhibition for each concentration of **CC-90003** relative to the no-inhibitor control.

Protocol 2: FLT3 Kinase Activity Assay

This protocol follows a similar principle to the KDR assay.

Materials:

- Recombinant FLT3 enzyme
- Kinase assay buffer
- ATP solution
- FLT3 substrate (e.g., a specific peptide substrate)
- **CC-90003**
- ADP-Glo™ Kinase Assay Kit
- White, opaque 96-well plates
- Luminometer

Procedure:

- Follow a similar setup to the KDR assay, preparing a master mix and adding inhibitor and enzyme to the plate.
- Initiate the reaction by adding the master mix.
- Incubate as required for the FLT3 enzyme.
- Add the ADP-Glo™ Reagent to terminate the kinase reaction and deplete the remaining ATP.
- Add the Kinase Detection Reagent to convert ADP to ATP and generate a luminescent signal.

- Measure luminescence and calculate percent inhibition.[8][9]

Protocol 3: PDGFR α Kinase Activity Assay

This protocol is also analogous to the preceding assays.

Materials:

- Recombinant PDGFR α enzyme
- Kinase assay buffer
- ATP solution
- PDGFR α substrate (e.g., Poly(Glu,Tyr) 4:1)
- **CC-90003**
- Kinase-Glo $\text{\textcircled{R}}$ or ADP-Glo TM Assay Kit
- White, opaque 96-well plates
- Luminometer

Procedure:

- Adapt the general kinase assay protocol described above for the specific requirements of the PDGFR α enzyme and the chosen luminescent assay kit.[10][11]

Visualizations

Signaling Pathways

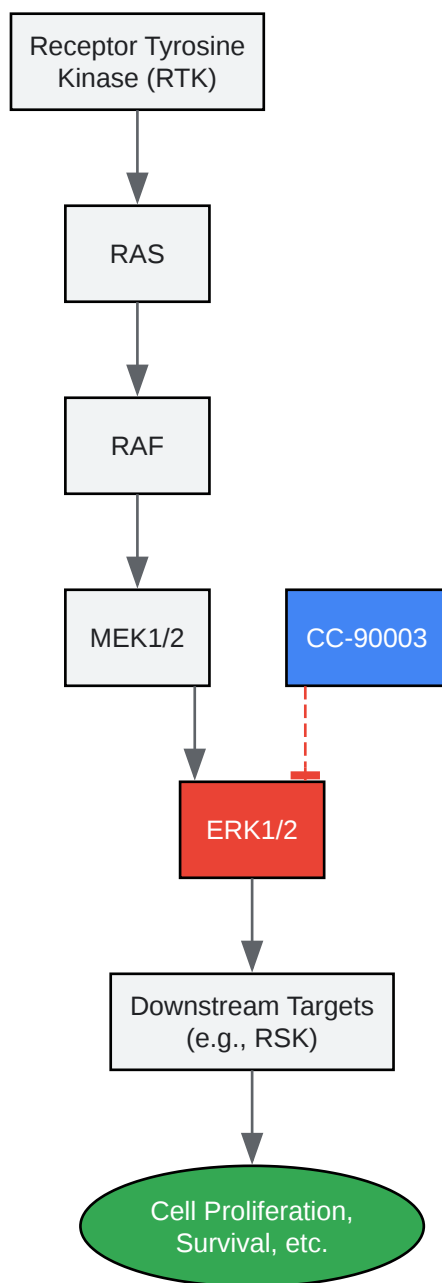

[Click to download full resolution via product page](#)

Caption: The MAPK/ERK signaling pathway and the point of inhibition by **CC-90003**.

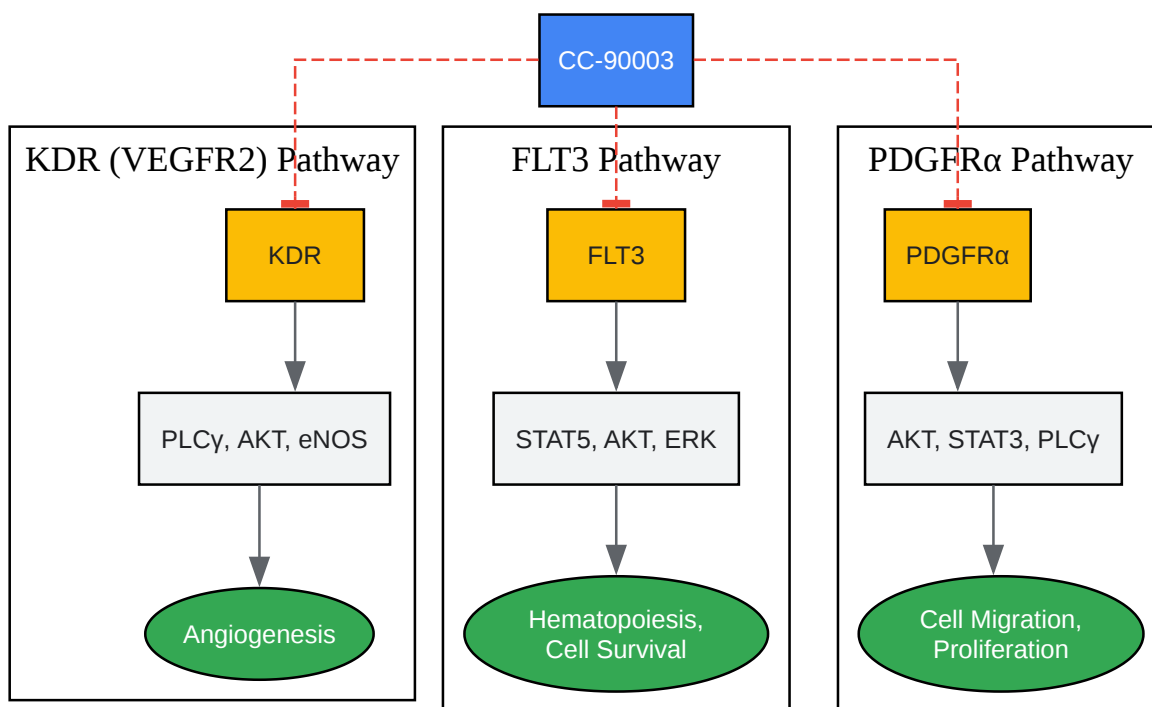

[Click to download full resolution via product page](#)

Caption: Known off-target kinases of **CC-90003** and their primary signaling outcomes.

Experimental Workflow

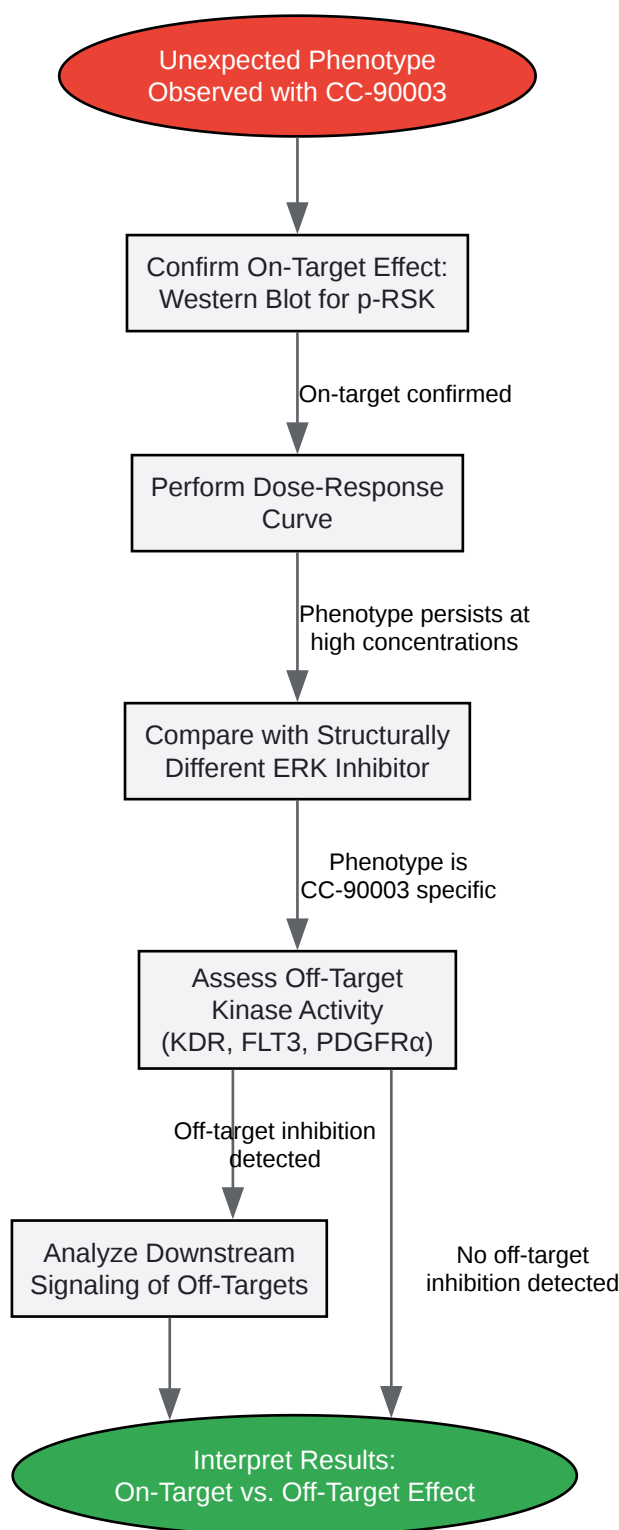

[Click to download full resolution via product page](#)

Caption: A logical workflow for troubleshooting unexpected experimental results with **CC-90003**.

Need Custom Synthesis?

BenchChem offers custom synthesis for rare earth carbides and specific isotopic labeling.

Email: info@benchchem.com or [Request Quote Online](#).

References

- [1. bpsbioscience.com \[bpsbioscience.com\]](https://bpsbioscience.com)
- [2. benchchem.com \[benchchem.com\]](https://www.benchchem.com)
- [3. researchgate.net \[researchgate.net\]](https://www.researchgate.net)
- [4. Investigation Into the Role of ERK in Tyrosine Kinase Inhibitor-Induced Neuropathy - PubMed \[pubmed.ncbi.nlm.nih.gov\]](#)
- [5. ascopubs.org \[ascopubs.org\]](https://ascopubs.org)
- [6. Downstream molecular pathways of FLT3 in the pathogenesis of acute myeloid leukemia: biology and therapeutic implications - PMC \[pmc.ncbi.nlm.nih.gov\]](#)
- [7. Novel molecular mechanisms of FLT3 deregulation: from the acute myeloid leukemia experience to therapeutic insights in acute lymphoblastic leukemia - PMC \[pmc.ncbi.nlm.nih.gov\]](#)
- [8. promega.com \[promega.com\]](https://www.promega.com)
- [9. promega.com \[promega.com\]](https://www.promega.com)
- [10. PDGFR alpha Kinase Enzyme System Application Note \[promega.com\]](#)
- [11. promega.com \[promega.com\]](https://www.promega.com)
- [To cite this document: BenchChem. \[Technical Support Center: Understanding and Troubleshooting Off-Target Effects of CC-90003\]. BenchChem, \[2026\]. \[Online PDF\]. Available at: \[https://www.benchchem.com/product/b10798849/docs#technical-support-center-understanding-and-troubleshooting-off-target-effects-of-cc-90003\]](#)

Disclaimer & Data Validity:

The information provided in this document is for Research Use Only (RUO) and is strictly not intended for diagnostic or therapeutic procedures. While BenchChem strives to provide accurate protocols, we make no warranties, express or implied, regarding the fitness of this product for every specific experimental setup.

Technical Support: The protocols provided are for reference purposes. Unsure if this reagent suits your experiment?

Need Industrial/Bulk Grade? [Request Custom Synthesis Quote](#)

BenchChem

Our mission is to be the trusted global source of essential and advanced chemicals, empowering scientists and researchers to drive progress in science and industry.

Contact

Address: 3281 E Guasti Rd
Ontario, CA 91761, United States
Phone: (601) 213-4426
Email: info@benchchem.com

[Contact our Ph.D. Support Team for a compatibility check](#)