

LDC4297 Hydrochloride: A Comparative Guide to Kinase Selectivity

Author: BenchChem Technical Support Team. **Date:** April 2026

Compound of Interest

Compound Name: LDC4297 hydrochloride

Cat. No.: B10798903

[Get Quote](#)

For Researchers, Scientists, and Drug Development Professionals

This guide provides a comprehensive comparison of the kinase selectivity of **LDC4297 hydrochloride** with other notable CDK7 inhibitors. The information presented herein is intended to assist researchers in making informed decisions for their experimental designs. All quantitative data is summarized for clear comparison, and detailed experimental methodologies are provided for key assays.

Introduction to LDC4297 Hydrochloride

LDC4297 hydrochloride is a potent and selective inhibitor of Cyclin-Dependent Kinase 7 (CDK7).^{[1][2]} CDK7 is a critical kinase that plays a dual role in the regulation of the cell cycle and transcription. It is a component of the CDK-activating kinase (CAK) complex, which is responsible for the activating phosphorylation of other CDKs, including CDK1, CDK2, CDK4, and CDK6. Additionally, as part of the general transcription factor TFIIH, CDK7 phosphorylates the C-terminal domain of RNA polymerase II, a key step in transcription initiation. Due to its central role in these fundamental cellular processes, CDK7 has emerged as a promising therapeutic target in oncology and virology.

Comparative Kinase Inhibition Profile

The following table summarizes the inhibitory activity of **LDC4297 hydrochloride** and other CDK7 inhibitors against a panel of kinases. The data highlights the selectivity profile of each compound, providing a basis for experimental application.

Kinase	LDC4297	THZ1	SY-1365	YKL-5-124	BS-181	ICEC0942 (CT7001)
CDK7	0.13 nM[1] [2]	3.2 nM	369 nM	9.7 nM[3]	21 nM[4]	40 nM[4]
CDK1	53.7 nM[5]	-	-	-	-	-
CDK2	6.4 nM[5]	-	>2 μ M	1.3 μ M[3]	>740 nM[3]	-
CDK4	>10 μ M[5]	-	-	-	-	-
CDK6	>10 μ M[5]	-	-	-	-	-
CDK9	1.71 μ M[5]	-	>2 μ M	3.02 μ M[3]	-	-
CDK12	-	equipotent to CDK7[6]	>2 μ M	>100 μ M[3]	-	-
CDK13	-	equipotent to CDK7[6]	-	>100 μ M[3]	-	-

Experimental Protocols

The determination of kinase inhibitor selectivity is crucial for understanding its biological effects and potential off-target activities. Below are detailed methodologies for commonly employed kinase assays.

Biochemical Kinase Assay for IC50 Determination (Example using a Luminescent Assay)

This protocol outlines a general procedure for determining the half-maximal inhibitory concentration (IC50) of a compound against a specific kinase, based on luminescence detection of ADP production.

Materials:

- Purified recombinant kinase (e.g., CDK7/Cyclin H/MAT1 complex)
- Kinase substrate peptide (e.g., Cdk7/9tide)
- Adenosine 5'-triphosphate (ATP)
- Kinase assay buffer (e.g., 40 mM Tris-HCl pH 7.5, 20 mM MgCl₂, 0.1 mg/mL BSA, 50 μM DTT)
- Test compound (e.g., **LDC4297 hydrochloride**) dissolved in 100% DMSO
- Luminescent kinase assay kit (e.g., ADP-Glo™)
- White, opaque 384-well assay plates
- Plate reader capable of measuring luminescence

Procedure:

- **Compound Preparation:** Prepare a serial dilution of the test compound in 100% DMSO. A common starting point is a 10-point, 3-fold dilution series starting from a high concentration (e.g., 1 mM). Further dilute the compound series in kinase assay buffer to a 4x final assay concentration. The final DMSO concentration in the assay should not exceed 1%.
- **Enzyme and Substrate Preparation:**
 - Prepare a 4x solution of the kinase enzyme in kinase assay buffer.
 - Prepare a 2x solution of the kinase substrate and ATP in kinase assay buffer. The ATP concentration should ideally be close to the K_m of the kinase.
- **Assay Plate Setup:**
 - To the wells of a 384-well plate, add 2.5 μL of the 4x compound dilutions.

- Include "positive control" wells (with DMSO vehicle instead of inhibitor) and "blank" or "negative control" wells (no enzyme).
- Kinase Reaction:
 - Initiate the reaction by adding 2.5 μL of the 4x kinase solution to all wells except the blanks.
 - Immediately follow with the addition of 5 μL of the 2x substrate/ATP mixture to all wells. The final reaction volume will be 10 μL .
 - Incubate the plate at room temperature for a predetermined time, ensuring the reaction is within the linear range.
- Signal Detection (using ADP-Glo™ as an example):
 - After incubation, add 5 μL of ADP-Glo™ Reagent to each well to stop the kinase reaction and deplete the remaining ATP. Incubate at room temperature for 40 minutes.
 - Add 10 μL of Kinase Detection Reagent to each well to convert the ADP generated into a luminescent signal. Incubate at room temperature for 30 minutes.
- Data Acquisition and Analysis:
 - Measure the luminescence of each well using a plate reader.
 - Calculate the percentage of kinase activity for each compound concentration relative to the positive control.
 - Plot the percentage of activity against the logarithm of the compound concentration to generate a dose-response curve and determine the IC50 value.

Kinome-wide Selectivity Profiling

To assess the broader selectivity of an inhibitor, a kinome-wide screening is performed. For LDC4297, a radiometric protein kinase assay (PanKinase activity assay) was utilized to profile its activity against over 330 human protein kinases.[7]

General Principle of Radiometric Kinase Assay:

This type of assay measures the incorporation of a radiolabeled phosphate group (from [γ - ^{32}P]ATP or [γ - ^{33}P]ATP) onto a specific substrate by the kinase.

- **Reaction Setup:** The kinase, substrate, and test compound are incubated in a reaction buffer containing radiolabeled ATP.
- **Reaction Termination and Separation:** The reaction is stopped, and the radiolabeled substrate is separated from the unreacted radiolabeled ATP. This is often achieved by spotting the reaction mixture onto a phosphocellulose membrane, which binds the phosphorylated substrate, followed by washing away the free ATP.
- **Detection:** The amount of radioactivity incorporated into the substrate is quantified using a scintillation counter or phosphorimager.
- **Analysis:** The percentage of inhibition is calculated by comparing the radioactivity in the presence of the inhibitor to that of a control reaction without the inhibitor.

Visualizations

CDK7 Signaling Pathway

The following diagram illustrates the dual role of CDK7 in regulating both cell cycle progression and transcription.

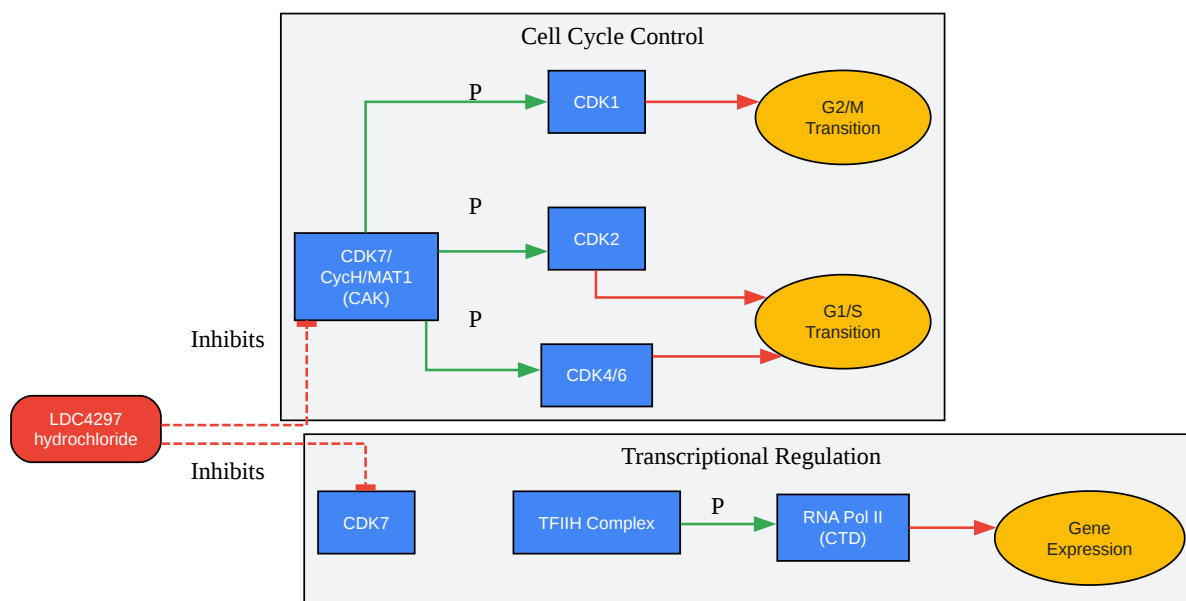

[Click to download full resolution via product page](#)

Caption: Dual roles of CDK7 in cell cycle and transcription, and its inhibition by LDC4297.

Kinase Inhibitor Screening Workflow

The diagram below outlines a typical workflow for screening kinase inhibitors and determining their IC50 values.

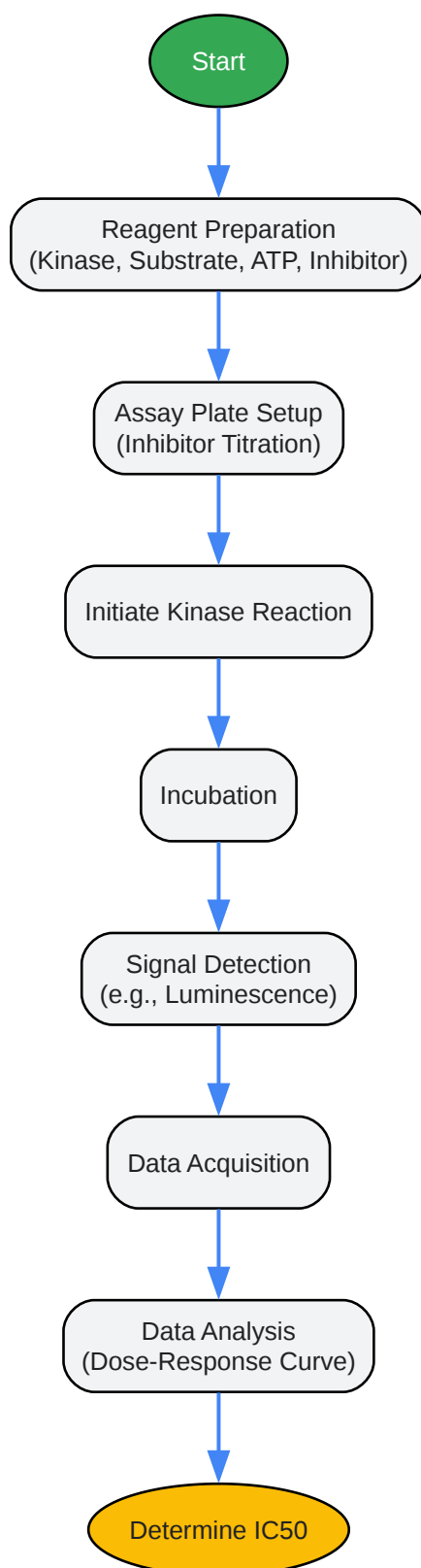

[Click to download full resolution via product page](#)

Caption: A generalized workflow for in vitro kinase inhibitor screening.

Need Custom Synthesis?

BenchChem offers custom synthesis for rare earth carbides and specific isotopic labeling.

Email: info@benchchem.com or [Request Quote Online](#).

References

- [1. medchemexpress.com](https://www.medchemexpress.com) [[medchemexpress.com](https://www.medchemexpress.com)]
- [2. medchemexpress.com](https://www.medchemexpress.com) [[medchemexpress.com](https://www.medchemexpress.com)]
- [3. tandfonline.com](https://www.tandfonline.com) [[tandfonline.com](https://www.tandfonline.com)]
- [4. Identification of CDK7 Inhibitors from Natural Sources Using Pharmacoinformatics and Molecular Dynamics Simulations - PMC](#) [[pmc.ncbi.nlm.nih.gov](https://pubmed.ncbi.nlm.nih.gov)]
- [5. caymanchem.com](https://www.caymanchem.com) [[caymanchem.com](https://www.caymanchem.com)]
- [6. Development of a selective CDK7 covalent inhibitor reveals predominant cell cycle phenotype - PMC](#) [[pmc.ncbi.nlm.nih.gov](https://pubmed.ncbi.nlm.nih.gov)]
- [7. A Novel CDK7 Inhibitor of the Pyrazolotriazine Class Exerts Broad-Spectrum Antiviral Activity at Nanomolar Concentrations - PMC](#) [[pmc.ncbi.nlm.nih.gov](https://pubmed.ncbi.nlm.nih.gov)]
- To cite this document: BenchChem. [LDC4297 Hydrochloride: A Comparative Guide to Kinase Selectivity]. BenchChem, [2026]. [Online PDF]. Available at: [<https://www.benchchem.com/product/b10798903/docs#ldc4297-hydrochloride-a-comparative-guide-to-kinase-selectivity>]

Disclaimer & Data Validity:

The information provided in this document is for Research Use Only (RUO) and is strictly not intended for diagnostic or therapeutic procedures. While BenchChem strives to provide accurate protocols, we make no warranties, express or implied, regarding the fitness of this product for every specific experimental setup.

Technical Support: The protocols provided are for reference purposes. Unsure if this reagent suits your experiment?

Need Industrial/Bulk Grade? [Request Custom Synthesis Quote](#)

BenchChem

Our mission is to be the trusted global source of essential and advanced chemicals, empowering scientists and researchers to drive progress in science and industry.

Contact

Address: 3281 E Guasti Rd

Ontario, CA 91761, United States

Phone: (601) 213-4426

Email: info@benchchem.com

[Contact our Ph.D. Support Team for a compatibility check](#)