

Refining RO8994 treatment protocols for long-term studies

Author: BenchChem Technical Support Team. **Date:** April 2026

Compound of Interest

Compound Name: RO8994
Cat. No.: B10796940

[Get Quote](#)

Technical Support Center: RO8994

Introduction: This technical support center provides essential information for researchers, scientists, and drug development professionals working with **RO8994**, a potent and selective spiroindolinone MDM2 inhibitor.^{[1][2][3]} This guide is designed to assist in refining long-term study protocols by offering troubleshooting advice, frequently asked questions (FAQs), and detailed experimental procedures.

Frequently Asked Questions (FAQs)

Q1: What is the mechanism of action for **RO8994**?

RO8994 is a small-molecule inhibitor that targets the interaction between the p53 tumor suppressor protein and its negative regulator, MDM2.^{[2][4]} By binding to MDM2, **RO8994** prevents the degradation of p53, leading to the activation of the p53 pathway and subsequent apoptosis in cancer cells with wild-type p53.

Q2: How should I prepare and store **RO8994** for long-term use?

For in vitro experiments, **RO8994** can be dissolved in fresh DMSO to create a high-concentration stock solution (e.g., 100 mg/mL). It is crucial to use fresh, moisture-free DMSO as absorbed moisture can reduce solubility. For long-term storage, aliquot the stock solution into smaller volumes and store at -80°C to minimize freeze-thaw cycles. For in vivo studies, the formulation will depend on the specific animal model and administration route. A common starting point is suspension in a vehicle such as 0.5% methylcellulose with 0.2% Tween 80.

Q3: My cells are showing decreased sensitivity to **RO8994** over time. What are the potential causes and how can I investigate this?

Decreased sensitivity, or acquired resistance, is a common challenge in long-term studies with targeted inhibitors. Potential mechanisms include:

- On-target modifications: Secondary mutations in the MDM2 gene that prevent **RO8994** from binding effectively.
- Activation of bypass pathways: Cancer cells may compensate for MDM2 inhibition by upregulating alternative survival pathways.
- Drug efflux: Increased expression of drug transporters that pump **RO8994** out of the cell.

To investigate these possibilities, you can perform sequencing of the MDM2 gene, conduct phospho-kinase arrays to screen for activated bypass pathways, and use qPCR to measure the expression of common drug resistance genes.

Q4: I am observing variability in my IC50 values for **RO8994** across experiments. What could be the cause?

Inconsistent IC50 values can stem from several factors. High variability is a common issue that can often be resolved by carefully reviewing experimental technique. Key areas to check include:

- Cell density: Ensure consistent cell seeding density as this can affect growth rates and drug response.
- Compound stability: Confirm that **RO8994** is stable in your culture medium over the duration of the assay.

- Reagent quality: Use high-quality, fresh reagents, including ATP and substrates, for your assays.
- Assay conditions: Maintain consistent incubation times and ensure that the assay is performed within the linear range of detection.

Troubleshooting Guides

This section provides solutions to specific problems you may encounter during your long-term experiments with **RO8994**.

Issue 1: Loss of **RO8994** Efficacy in Long-Term In Vitro Cultures

- Problem: After several weeks of continuous treatment, the concentration of **RO8994** required to induce apoptosis has significantly increased.
- Possible Cause: Development of acquired resistance. This can be due to genetic changes in the target protein or the activation of compensatory signaling pathways.
- Troubleshooting Steps:
 - Confirm Target Engagement: Perform a Western blot to check the levels of p53 and its downstream target, p21. A lack of p53 accumulation upon treatment suggests a problem with target engagement.
 - Sequence MDM2: Isolate genomic DNA from resistant cells and sequence the MDM2 gene to check for mutations in the **RO8994** binding site.
 - Profile for Bypass Pathways: Use a phospho-kinase array to compare the signaling pathways active in resistant cells versus the parental, sensitive cells. Upregulation of pathways like PI3K/Akt or MAPK/ERK could indicate a bypass mechanism.

Issue 2: Poor In Vivo Efficacy Despite Good In Vitro Potency

- Problem: **RO8994** shows a potent IC50 in the nanomolar range in vitro, but tumor growth in xenograft models is not significantly inhibited.

- Possible Cause: Suboptimal pharmacokinetics (PK) or pharmacodynamics (PD). The compound may not be reaching the tumor at a sufficient concentration or for a long enough duration.
- Troubleshooting Steps:
 - Conduct a PK Study: Measure the concentration of **RO8994** in the plasma and tumor tissue over time after administration. This will determine the compound's bioavailability and tissue penetration.
 - Assess Target Inhibition In Vivo: Collect tumor samples at various time points after dosing and perform a Western blot for p53 and p21 to confirm that **RO8994** is inhibiting its target in the tumor.
 - Optimize Dosing Regimen: Based on the PK/PD data, adjust the dose and frequency of administration to maintain a therapeutic concentration of **RO8994** in the tumor.

Data Presentation

Table 1: Long-Term IC50 Shift of **RO8994** in Various Cancer Cell Lines

Cell Line	Cancer Type	Initial IC50 (nM)	IC50 after 3 Months (nM)	Fold Change
SJSA-1	Osteosarcoma	25	350	14.0
RKO	Colon Carcinoma	40	620	15.5
HCT116	Colon Carcinoma	35	550	15.7

Table 2: Recommended Starting Doses for In Vivo Studies

Animal Model	Administration Route	Vehicle	Starting Dose (mg/kg)	Dosing Frequency
Mouse (Xenograft)	Oral (gavage)	0.5% MC, 0.2% Tween 80	50	Once daily
Rat (Orthotopic)	Intraperitoneal	10% DMSO, 40% PEG300	25	Twice daily

Experimental Protocols

Protocol 1: Western Blot for p53 and p21 Induction

- Cell Lysis: Treat cells with the desired concentration of **RO8994** for the specified time. Wash cells with ice-cold PBS and lyse with RIPA buffer containing protease and phosphatase inhibitors.
- Protein Quantification: Determine the protein concentration of each lysate using a BCA assay.
- Gel Electrophoresis: Load equal amounts of protein (20-30 μ g) onto an SDS-PAGE gel and separate by electrophoresis.
- Protein Transfer: Transfer the separated proteins to a PVDF membrane.
- Blocking: Block the membrane with 5% non-fat milk or BSA in TBST for 1 hour at room temperature.
- Primary Antibody Incubation: Incubate the membrane with primary antibodies against p53, p21, and a loading control (e.g., GAPDH or β -actin) overnight at 4°C.
- Secondary Antibody Incubation: Wash the membrane with TBST and incubate with the appropriate HRP-conjugated secondary antibody for 1 hour at room temperature.
- Detection: Visualize the protein bands using an ECL detection reagent and an imaging system.

Protocol 2: Cell Viability Assay for IC50 Determination

- **Cell Seeding:** Seed cells in a 96-well plate at a predetermined optimal density and allow them to adhere overnight.
- **Compound Treatment:** Prepare a serial dilution of **RO8994** in culture medium and add it to the wells. Include a vehicle-only control.
- **Incubation:** Incubate the plate for 72 hours (or a time point relevant to your cell line).
- **Viability Reagent:** Add a cell viability reagent (e.g., CellTiter-Glo® or MTT) to each well according to the manufacturer's instructions.
- **Data Acquisition:** Measure the luminescence or absorbance using a plate reader.
- **Data Analysis:** Normalize the data to the vehicle control and plot the results as a dose-response curve to calculate the IC50 value using non-linear regression.

Visualizations

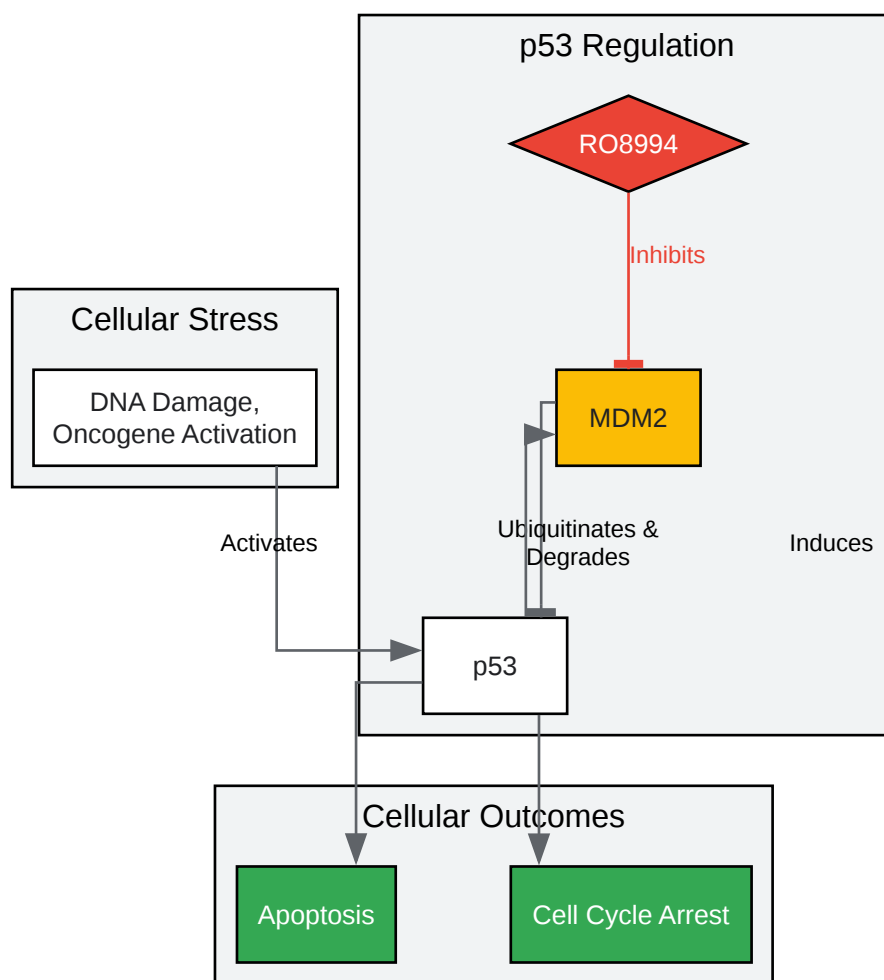

[Click to download full resolution via product page](#)

Caption: **RO8994** inhibits MDM2, stabilizing p53 to promote apoptosis.

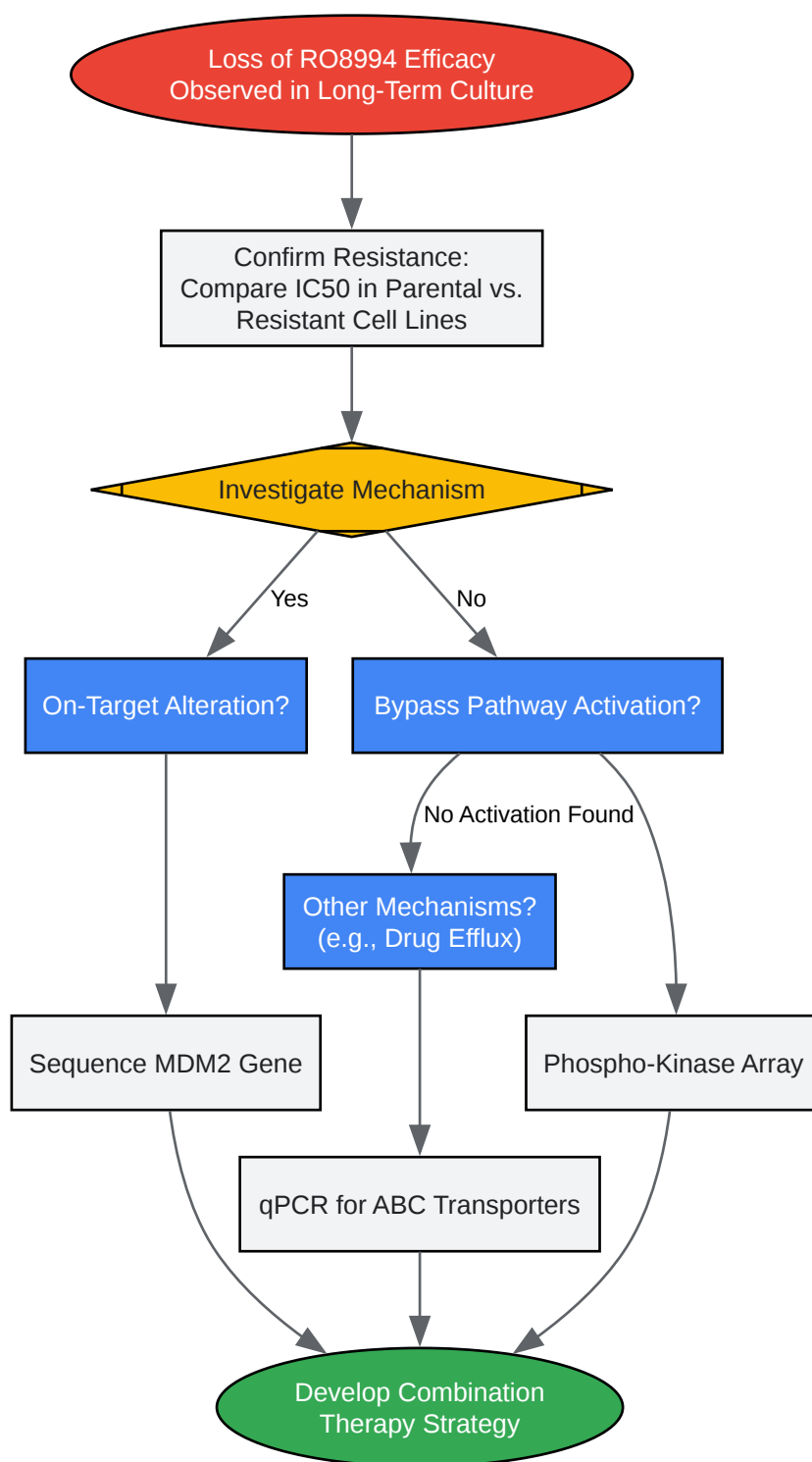

[Click to download full resolution via product page](#)

Caption: Troubleshooting workflow for acquired resistance to **RO8994**.

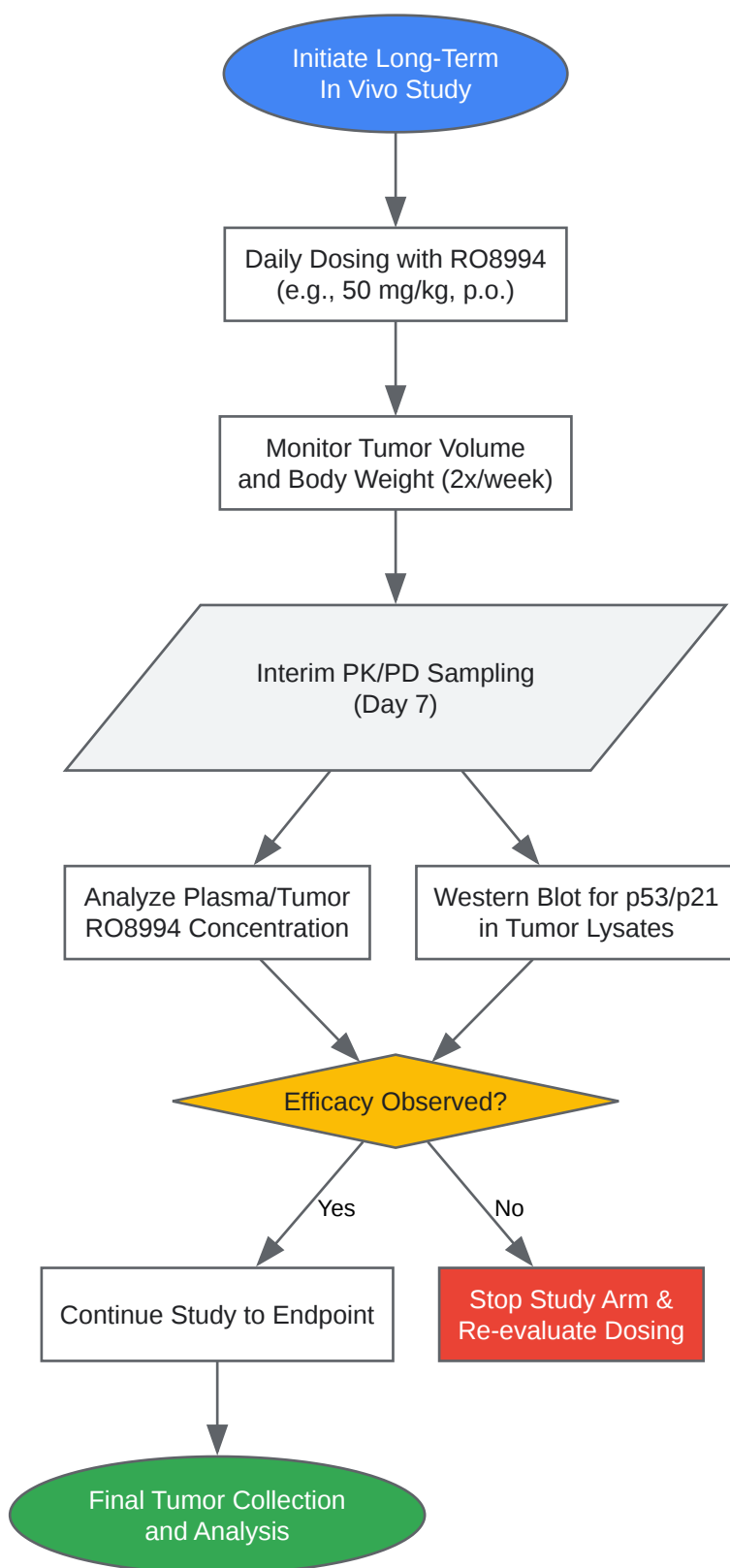

[Click to download full resolution via product page](#)

Caption: Workflow for a long-term in vivo efficacy study of **RO8994**.

Need Custom Synthesis?

BenchChem offers custom synthesis for rare earth carbides and specific isotopic labeling.

Email: info@benchchem.com or [Request Quote Online](#).

References

- [1. selleckchem.com \[selleckchem.com\]](https://www.selleckchem.com)
- [2. Discovery of potent and selective spiroindolinone MDM2 inhibitor, RO8994, for cancer therapy - PubMed \[pubmed.ncbi.nlm.nih.gov\]](#)
- [3. medkoo.com \[medkoo.com\]](https://www.medkoo.com)
- [4. researchgate.net \[researchgate.net\]](https://www.researchgate.net)
- To cite this document: BenchChem. [Refining RO8994 treatment protocols for long-term studies]. BenchChem, [2026]. [Online PDF]. Available at: [\[https://www.benchchem.com/product/b10796940/docs#refining-ro8994-treatment-protocols-for-long-term-studies\]](https://www.benchchem.com/product/b10796940/docs#refining-ro8994-treatment-protocols-for-long-term-studies)

Disclaimer & Data Validity:

The information provided in this document is for Research Use Only (RUO) and is strictly not intended for diagnostic or therapeutic procedures. While BenchChem strives to provide accurate protocols, we make no warranties, express or implied, regarding the fitness of this product for every specific experimental setup.

Technical Support: The protocols provided are for reference purposes. Unsure if this reagent suits your experiment?

Need Industrial/Bulk Grade? [Request Custom Synthesis Quote](#)

BenchChem

Our mission is to be the trusted global source of essential and advanced chemicals, empowering scientists and researchers to drive progress in science and industry.

Contact

Address: 3281 E Guasti Rd

Ontario, CA 91761, United States

Phone: (601) 213-4426

Email: info@benchchem.com

[Contact our Ph.D. Support Team for a compatibility check](#)