

# Identifying and mitigating off-target effects of BPH-1358

**Author:** BenchChem Technical Support Team. **Date:** April 2026

## Compound of Interest

Compound Name: BPH-1358

Cat. No.: B10796805

[Get Quote](#)

## Technical Support Center: BPH-1358

This technical support center provides researchers, scientists, and drug development professionals with guidance on identifying and mitigating potential off-target effects of **BPH-1358**.

## Frequently Asked Questions (FAQs)

Q1: What is **BPH-1358** and what are its known on-targets?

**BPH-1358** is a dual inhibitor of Farnesyl diphosphate synthase (FPPS) and Undecaprenyl diphosphate synthase (UPPS).[1] It has been investigated for its anti-bacterial activity, particularly against *Staphylococcus aureus*. [1] FPPS is a key enzyme in the mevalonate pathway in a wide range of organisms, including humans, while UPPS is involved in bacterial cell wall biosynthesis and is not present in humans.[1][2]

Q2: Does "BPH" in **BPH-1358** refer to Benign Prostatic Hyperplasia?

This appears to be a misnomer. The known mechanism of action of **BPH-1358** as a dual FPPS/UPPS inhibitor is not directly related to the pathways typically targeted in the treatment

of Benign Prostatic Hyperplasia (BPH). Standard BPH therapies often involve alpha-blockers or 5-alpha-reductase inhibitors. Researchers should not assume a therapeutic application in BPH based on the compound's name.

Q3: What are the potential off-target effects of **BPH-1358**?

While specific off-target effects for **BPH-1358** are not extensively documented in publicly available literature, potential off-target effects can be hypothesized based on its known targets and chemical properties:

- **Disruption of the Mevalonate Pathway:** As an FPPS inhibitor, **BPH-1358** can affect downstream processes such as protein prenylation (e.g., of Ras and Rho GTPases), which is crucial for various cellular signaling pathways.[3] Inhibition of FPPS can lead to the accumulation of upstream intermediates, which may have their own biological activities.
- **Effects on Membrane Potential:** Some inhibitors of UPPS have been noted to have off-target effects on the cell membrane potential, often due to their physicochemical properties.
- **Tissue-Specific Accumulation:** **BPH-1358** is described as lipophilic. Similar to other lipophilic small molecules, it may accumulate in specific tissues, potentially leading to localized off-target effects.

Q4: Are there any known adverse effects of **BPH-1358** in vivo?

In a mouse model of *S. aureus* infection, **BPH-1358** reportedly showed no apparent adverse reactions. However, this does not preclude the possibility of off-target effects in other experimental models, at different concentrations, or with prolonged exposure.

## Troubleshooting Guide

This guide addresses specific issues that may arise during experiments with **BPH-1358**.

Issue 1: Unexpected cellular phenotype observed (e.g., cytotoxicity, changes in cell morphology, altered signaling pathways).

- **Possible Cause:** Off-target inhibition of other cellular kinases or enzymes, or disruption of the mevalonate pathway.

- Troubleshooting Steps:
  - Dose-Response Analysis: Perform a dose-response experiment to determine if the observed phenotype occurs at concentrations significantly different from the IC50 for on-target (FPPS/UPPS) inhibition.
  - Rescue Experiments:
    - Supplement cells with downstream products of the mevalonate pathway (e.g., geranylgeranyl pyrophosphate) to see if the phenotype can be rescued.
    - Overexpress the on-target enzyme (FPPS in mammalian cells) to see if this mitigates the observed effect.
  - Use of a Structurally Different Inhibitor: Compare the cellular phenotype induced by **BPH-1358** with that of a structurally unrelated FPPS inhibitor (e.g., a bisphosphonate). If the phenotype is not recapitulated, it may be an off-target effect specific to the chemical scaffold of **BPH-1358**.
  - Off-Target Profiling: If the phenotype is persistent and concerning, consider commercial off-target screening services (e.g., kinase profiling panels).

Issue 2: Inconsistent results between different cell lines.

- Possible Cause: Varying expression levels of the on-target (FPPS) or potential off-target proteins in different cell lines.
- Troubleshooting Steps:
  - Target Expression Analysis: Quantify the protein levels of FPPS in the cell lines being used via Western blot or proteomics.
  - Metabolic State of Cells: The activity of the mevalonate pathway can vary between cell lines. Consider the metabolic state of your cells as a potential variable.

Issue 3: Discrepancy between in vitro enzymatic activity and cellular potency.

- Possible Cause: Poor cell permeability, active efflux from the cell, or rapid metabolism of the compound. Off-target effects at the cellular level can also contribute.
- Troubleshooting Steps:
  - Cellular Thermal Shift Assay (CETSA): To confirm target engagement in intact cells.
  - Permeability Assays: Use in vitro models like PAMPA to assess cell permeability.
  - Metabolic Stability Assays: Evaluate the stability of **BPH-1358** in the presence of liver microsomes or in cell culture medium.

## Quantitative Data Summary

Compound	Target	IC50	Reference
BPH-1358	Human FPPS	2 nM	
BPH-1358	E. coli UPPS	110 nM	
BPH-1358	S. aureus UPPS	110 nM	

## Experimental Protocols

### Protocol 1: Cellular Thermal Shift Assay (CETSA) for Target Engagement

This protocol determines if **BPH-1358** binds to its intended target (FPPS) in a cellular context.

- Cell Treatment: Culture cells to 80-90% confluency. Treat one group of cells with **BPH-1358** at the desired concentration and a control group with vehicle (e.g., DMSO). Incubate for the desired time.
- Harvest and Lyse: Harvest the cells, wash with PBS, and resuspend in a suitable lysis buffer with protease inhibitors.
- Heat Treatment: Aliquot the cell lysates into PCR tubes. Heat the aliquots at a range of temperatures (e.g., 40°C to 70°C) for 3 minutes, followed by cooling at room temperature for 3 minutes.

- Separation of Soluble and Aggregated Proteins: Centrifuge the heated lysates at high speed (e.g., 20,000 x g) for 20 minutes to pellet the aggregated proteins.
- Analysis: Collect the supernatant (soluble fraction) and analyze the amount of soluble FPPS by Western blotting.
- Expected Outcome: In the **BPH-1358**-treated samples, FPPS should remain soluble at higher temperatures compared to the vehicle control, indicating stabilization upon ligand binding.

#### Protocol 2: Western Blot for Mevalonate Pathway Disruption

This protocol assesses the impact of **BPH-1358** on protein prenylation, a downstream effect of FPPS inhibition.

- Cell Treatment and Lysis: Treat cells with **BPH-1358** or a vehicle control for 24-48 hours. Lyse the cells in RIPA buffer with protease and phosphatase inhibitors.
- Protein Quantification: Determine the protein concentration of the lysates using a BCA assay.
- SDS-PAGE and Western Blot: Separate equal amounts of protein on an SDS-PAGE gel and transfer to a PVDF membrane.
- Antibody Incubation: Probe the membrane with primary antibodies against unprenylated forms of small GTPases (e.g., unprenylated Rap1A) or antibodies that recognize total levels of these proteins. Also, probe for a loading control (e.g., GAPDH or  $\beta$ -actin).
- Detection and Analysis: Use a suitable secondary antibody and chemiluminescent substrate for detection. Quantify the band intensities.
- Expected Outcome: An increase in the unprenylated form of the GTPase in **BPH-1358**-treated cells would indicate effective inhibition of the mevalonate pathway.

## Visualizations

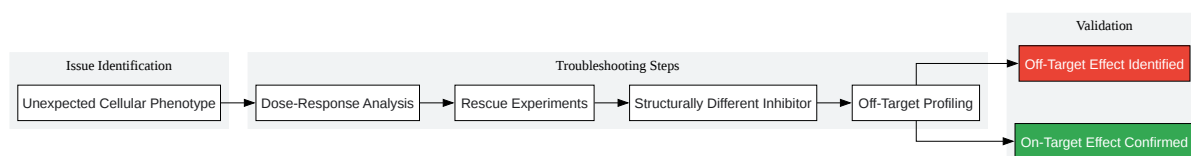

[Click to download full resolution via product page](#)

Caption: Troubleshooting workflow for an unexpected cellular phenotype.

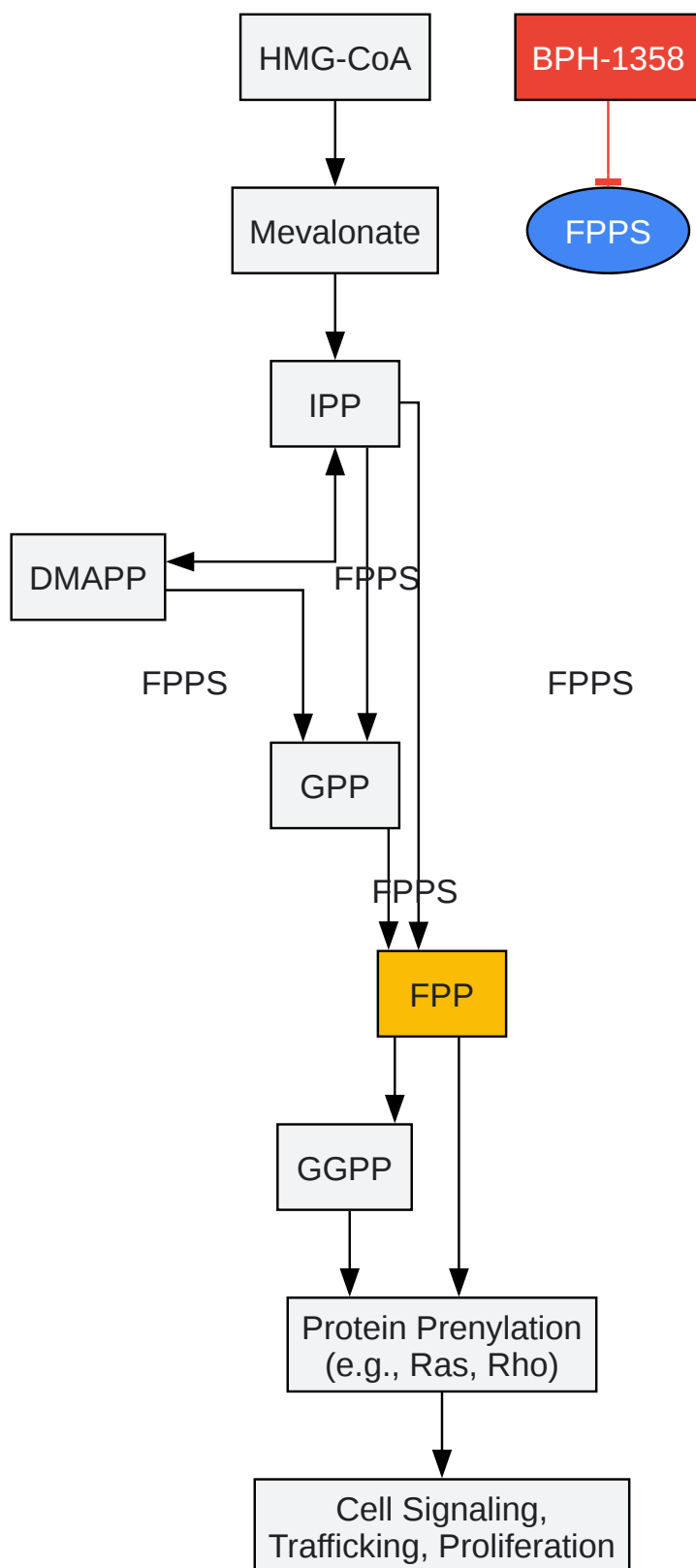

[Click to download full resolution via product page](#)

Caption: The mevalonate pathway and the point of inhibition by **BPH-1358**.

### Need Custom Synthesis?

BenchChem offers custom synthesis for rare earth carbides and specific isotopic labeling.

Email: [info@benchchem.com](mailto:info@benchchem.com) or [Request Quote Online](#).

## References

- [1. immune-system-research.com \[immune-system-research.com\]](https://immune-system-research.com)
- [2. A Small-Molecule Screening Platform for the Discovery of Inhibitors of Undecaprenyl Diphosphate Synthase — Brown Lab \[brownlab.ca\]](#)
- [3. What are FDPS inhibitors and how do they work? \[synapse.patsnap.com\]](#)
- To cite this document: BenchChem. [Identifying and mitigating off-target effects of BPH-1358]. BenchChem, [2026]. [Online PDF]. Available at: [\[https://www.benchchem.com/product/b10796805/docs#identifying-and-mitigating-off-target-effects-of-bph-1358\]](https://www.benchchem.com/product/b10796805/docs#identifying-and-mitigating-off-target-effects-of-bph-1358)

---

### Disclaimer & Data Validity:

The information provided in this document is for Research Use Only (RUO) and is strictly not intended for diagnostic or therapeutic procedures. While BenchChem strives to provide accurate protocols, we make no warranties, express or implied, regarding the fitness of this product for every specific experimental setup.

**Technical Support:** The protocols provided are for reference purposes. Unsure if this reagent suits your experiment?

**Need Industrial/Bulk Grade?** [Request Custom Synthesis Quote](#)

# BenchChem

Our mission is to be the trusted global source of essential and advanced chemicals, empowering scientists and researchers to drive progress in science and industry.

## Contact

Address: 3281 E Guasti Rd

Ontario, CA 91761, United States

Phone: (601) 213-4426

Email: [info@benchchem.com](mailto:info@benchchem.com)

[Contact our Ph.D. Support Team for a compatibility check](#)