

# Application Notes and Protocols for 5,6-Dehydroarachidonic Acid

**Author:** BenchChem Technical Support Team. **Date:** April 2026

## Compound of Interest

Compound Name: 5, 6-Dehydroarachidonic acid

Cat. No.: B10795301

[Get Quote](#)

Prepared by: Gemini, Senior Application Scientist

## Introduction: Understanding 5,6-Dehydroarachidonic Acid

5,6-Dehydroarachidonic acid (5,6-DHA) is a synthetic analog of the essential omega-6 polyunsaturated fatty acid, arachidonic acid (AA).[1] Its defining structural feature is the presence of an acetylene triple bond at the 5,6 position, replacing the cis-double bond found in its parent molecule.[1][2] This modification confers unique biochemical properties, most notably its function as a potent inhibitor of 5-lipoxygenase (5-LO), a key enzyme in the biosynthesis of pro-inflammatory leukotrienes.[1][3] This makes 5,6-DHA a valuable tool for researchers in inflammation, immunology, and cancer biology to investigate the roles of the 5-LO pathway in various physiological and pathological processes.

Beyond its role as a 5-LO inhibitor, 5,6-DHA can also serve as a substrate for other enzymes in the arachidonic acid cascade, such as cytochrome P450 (CYP) monooxygenases.[4][5] Its metabolism can lead to the formation of novel bioactive lipids, including stable lactone derivatives with potential vasodilatory effects.[6][7] The study of 5,6-DHA and its metabolites can, therefore, provide deeper insights into the complex network of lipid signaling.

This guide provides detailed protocols for the handling, preparation, and application of 5,6-DHA in common experimental settings. The methodologies are designed to ensure data integrity and reproducibility, with an emphasis on the scientific rationale behind each step.

## PART 1: Material Preparation and Handling

### Properties and Storage

Proper storage and handling are critical to maintaining the stability and activity of 5,6-DHA. As a polyunsaturated fatty acid, it is susceptible to oxidation.[8]

Property	Value	Source
Formal Name	(8Z,11Z,14Z)-eicosatrien-5-ynoic acid	[1]
CAS Number	58688-54-3	[1]
Molecular Formula	C <sub>20</sub> H <sub>30</sub> O <sub>2</sub>	[9]
Molecular Weight	302.5 g/mol	[9]
Purity	≥98%	[1][9]
Storage	-20°C	[1][3]
Shipping	Wet ice	[1][3]

Causality Behind Storage Conditions: Storage at -20°C in an oxygen-free environment (e.g., under argon or nitrogen) minimizes the rate of oxidation of the double and triple bonds, which would otherwise lead to degradation and loss of biological activity.[8][10]

### Preparation of Stock Solutions

The lipophilic nature of 5,6-DHA necessitates the use of organic solvents for initial solubilization.

#### Protocol 1: Stock Solution Preparation

- **Solvent Selection:** Use an anhydrous (dry) organic solvent. Dimethyl sulfoxide (DMSO) or ethanol are common choices.[1][11] For 5,6-DHA, it is often supplied in an ethanol solution.

[1][9]

- Reconstitution: If obtained as a solid, allow the vial to equilibrate to room temperature before opening to prevent condensation. Reconstitute in the chosen solvent to a high concentration (e.g., 10-50 mM).
- Mixing: Vortex or sonicate gently to ensure complete dissolution.[11]
- Aliquoting and Storage: Aliquot the stock solution into small, single-use volumes in amber glass or polypropylene vials. Overlay with an inert gas (argon or nitrogen) before sealing. Store at -20°C or -80°C to minimize freeze-thaw cycles.[11]

Trustworthiness of this Protocol: Aliquoting prevents repeated warming and cooling of the main stock, which can introduce moisture and accelerate degradation. Using inert gas displaces oxygen, further protecting the compound from oxidative damage.

## PART 2: Experimental Protocols

### In Vitro 5-Lipoxygenase (5-LO) Inhibition Assay

This spectrophotometric assay provides a direct measure of 5,6-DHA's ability to inhibit purified 5-LO enzyme activity. The principle lies in monitoring the formation of a conjugated diene hydroperoxide from a fatty acid substrate (like linoleic or arachidonic acid), which results in an increase in absorbance at 234 nm.[1][12]

Diagram 1: Workflow for In Vitro 5-LO Inhibition Assay

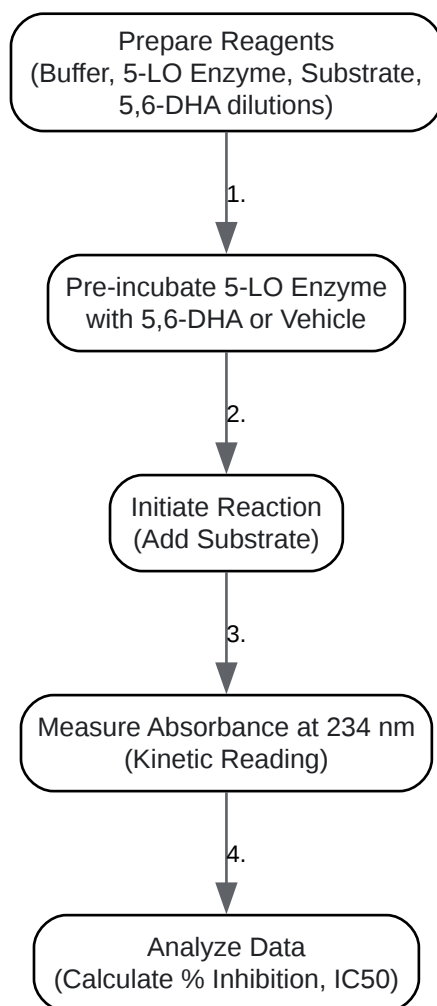

[Click to download full resolution via product page](#)

Caption: A generalized workflow for screening 5-LO inhibitors.[13]

#### Protocol 2: Spectrophotometric 5-LO Inhibition Assay

- Reagent Preparation:
  - Assay Buffer: 50 mM phosphate buffer, pH 6.3.[6]
  - 5-LO Enzyme: Recombinant human 5-LO or a suitable alternative (e.g., potato 5-LO). Prepare a working solution in ice-cold assay buffer. The final concentration should be determined empirically to yield a linear absorbance increase over 5-10 minutes.
  - Substrate: Prepare an 80 mM solution of linoleic acid or arachidonic acid in ethanol.

- 5,6-DHA: Prepare a series of dilutions from your stock solution in the assay buffer. A typical final concentration range to test for IC50 determination would be 1  $\mu$ M to 100  $\mu$ M. [\[1\]](#)
- Assay Procedure (96-well UV-transparent plate):
  - To each well, add:
    - x  $\mu$ L of assay buffer.
    - 10  $\mu$ L of 5,6-DHA dilution (or vehicle, e.g., DMSO/ethanol, for control).
    - 10  $\mu$ L of 5-LO enzyme solution.
  - Pre-incubate the plate at 25°C for 5 minutes.
  - Initiate the reaction by adding 5  $\mu$ L of the substrate solution to each well.
  - Immediately begin reading the absorbance at 234 nm every 30 seconds for 10 minutes using a microplate reader.
- Data Analysis:
  - Calculate the rate of reaction (V) for each concentration (mOD/min).
  - Calculate the percentage of inhibition for each concentration of 5,6-DHA using the formula:  
% Inhibition =  $[(V_{\text{control}} - V_{\text{inhibitor}}) / V_{\text{control}}] * 100$
  - Plot the % Inhibition against the logarithm of the 5,6-DHA concentration and fit the data to a dose-response curve to determine the IC50 value.[\[13\]](#)

Expertise Behind the Protocol: Pre-incubation of the enzyme with the inhibitor allows for binding to occur before the substrate is introduced, providing a more accurate measure of inhibitory potential. Using a kinetic read, rather than a single endpoint, ensures the initial reaction velocity is captured, which is crucial for accurate enzyme kinetics.

## Cell-Based 5-Lipoxygenase (5-LO) Activity Assay

This protocol assesses the efficacy of 5,6-DHA in a more physiologically relevant context by measuring its ability to inhibit 5-LO activity within intact cells. This accounts for factors like cell permeability and intracellular interactions.[13]

### Protocol 3: Cellular 5-LO Activity Assay

- Cell Culture:
  - Use a suitable cell line expressing 5-LO, such as human polymorphonuclear leukocytes (PMNLs) or THP-1 monocytes.[8][13]
  - Culture cells to the appropriate density in 96-well plates (e.g.,  $1 \times 10^5$  cells/well).[8]
- Inhibitor Treatment:
  - Prepare working solutions of 5,6-DHA in the cell culture medium. Ensure the final solvent concentration is non-toxic (typically <0.1% DMSO).
  - Remove the old medium from the cells and add the medium containing various concentrations of 5,6-DHA or vehicle.
  - Pre-incubate the cells for 30-60 minutes at 37°C in a CO2 incubator.
- Stimulation of 5-LO Activity:
  - Stimulate the cells with a calcium ionophore (e.g., A23187, 1-5  $\mu$ M) and arachidonic acid (10-20  $\mu$ M) to induce 5-LO product formation.
  - Incubate for an additional 15-30 minutes at 37°C.
- Quantification of 5-LO Products:
  - Terminate the reaction by centrifuging the plate and collecting the supernatant.
  - Measure the amount of a specific 5-LO product (e.g., Leukotriene B4) in the supernatant using a commercially available ELISA kit, following the manufacturer's instructions.
- Data Analysis:

- Calculate the percentage inhibition of LTB<sub>4</sub> production for each 5,6-DHA concentration relative to the vehicle-treated, stimulated control.
- Determine the IC<sub>50</sub> value by plotting the percentage inhibition against the log of the inhibitor concentration.

Trustworthiness of this Protocol: This cell-based assay provides a self-validating system. A positive control (stimulated cells with vehicle) confirms 5-LO activation, while a negative control (unstimulated cells) establishes the baseline. The dose-dependent inhibition by 5,6-DHA validates its specific effect on the cellular 5-LO pathway.

## In Vitro Cytochrome P450 (CYP) Metabolism Assay

This assay determines if 5,6-DHA is a substrate for CYP enzymes using liver microsomes, which are rich in these enzymes. The protocol measures the rate of disappearance of the parent compound (5,6-DHA) over time.[4][9]

Diagram 2: Arachidonic Acid Metabolic Pathways

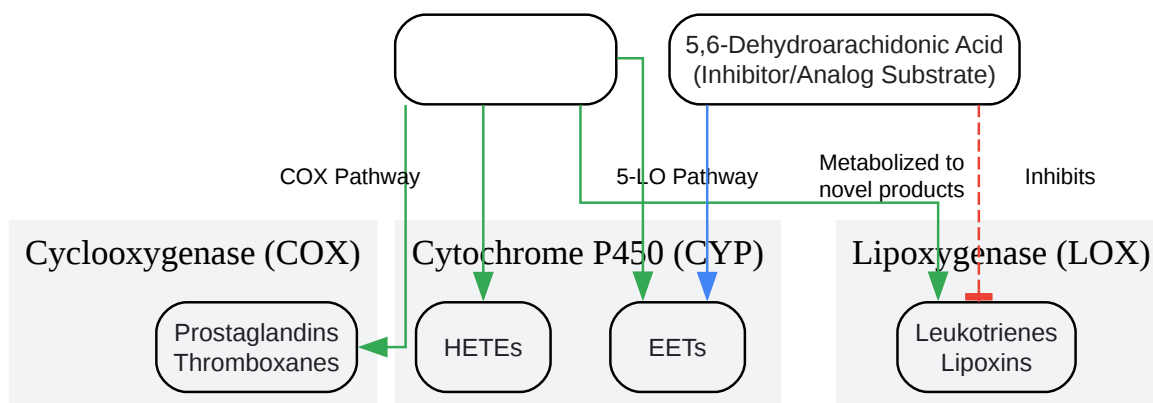

[Click to download full resolution via product page](#)

Caption: Major metabolic pathways of arachidonic acid and the role of 5,6-DHA.

### Protocol 4: Microsomal Stability Assay

- Reagent Preparation:

- Buffer: 100 mM potassium phosphate buffer, pH 7.4.
- Human Liver Microsomes (HLM): Thaw on ice. Dilute in buffer to a working concentration (e.g., 0.5-1 mg/mL protein).[9]
- 5,6-DHA: Prepare a working solution (e.g., 100  $\mu$ M) in buffer from your stock. The final concentration in the assay is typically 1-10  $\mu$ M.
- NADPH Regenerating System (NRS): Prepare a solution containing NADP<sup>+</sup>, glucose-6-phosphate, and glucose-6-phosphate dehydrogenase in buffer. Commercial kits are available.
- Quenching Solution: Acetonitrile containing an internal standard (e.g., a structurally similar but chromatographically distinct fatty acid).
- Assay Procedure:
  - Pre-warm HLM, buffer, and 5,6-DHA solutions to 37°C.
  - In a microcentrifuge tube, combine the HLM and 5,6-DHA in buffer.
  - Initiate the metabolic reaction by adding the NRS.
  - At various time points (e.g., 0, 5, 15, 30, 60 minutes), withdraw an aliquot of the reaction mixture and add it to a tube containing ice-cold quenching solution to stop the reaction.
  - Include a control reaction without the NRS to assess non-enzymatic degradation.
- Sample Analysis:
  - Centrifuge the quenched samples to pellet the protein.
  - Transfer the supernatant to an autosampler vial.
  - Analyze the concentration of remaining 5,6-DHA by Liquid Chromatography-Mass Spectrometry (LC-MS/MS).
- Data Analysis:

- Plot the natural log of the percentage of 5,6-DHA remaining versus time.
- The slope of the linear portion of the curve represents the elimination rate constant (k).
- Calculate the in vitro half-life ( $t_{1/2}$ ) using the formula:  $t_{1/2} = 0.693 / k$ .

## Cellular Lipid Peroxidation Assay

Polyunsaturated fatty acids can increase cellular oxidative stress, leading to lipid peroxidation. This assay measures malondialdehyde (MDA), a common byproduct of this process.[\[2\]](#)[\[10\]](#)

### Protocol 5: Thiobarbituric Acid Reactive Substances (TBARS) Assay

- Cell Treatment:
  - Seed cells (e.g., A549, HepG2) in 6-well plates and grow to 80-90% confluency.
  - Treat cells with various concentrations of 5,6-DHA or a positive control (e.g., arachidonic acid, H<sub>2</sub>O<sub>2</sub>) for a specified time (e.g., 16-24 hours).
- Sample Preparation:
  - Wash cells with ice-cold PBS.
  - Lyse the cells in MDA lysis buffer containing an antioxidant like butylated hydroxytoluene (BHT) to prevent ex vivo oxidation.[\[2\]](#)[\[14\]](#)
  - Homogenize or sonicate the lysate on ice.
  - Centrifuge at high speed (e.g., 13,000 x g) for 10 minutes to pellet debris.[\[2\]](#) Collect the supernatant.
- TBARS Reaction:
  - Use a commercial TBARS assay kit or prepare the reagents manually.
  - Add thiobarbituric acid (TBA) solution to the cell lysate supernatant.

- Incubate the mixture at 95°C for 60 minutes. This allows the MDA in the sample to react with TBA.
- Cool the samples on ice to stop the reaction.
- Measurement:
  - Centrifuge the samples to pellet any precipitate.
  - Measure the absorbance of the supernatant at 532 nm or fluorescence at Ex/Em = 530/550 nm.
- Data Analysis:
  - Create a standard curve using an MDA standard (e.g., 1,1,3,3-tetramethoxypropane).[\[10\]](#)
  - Quantify the amount of MDA in your samples by comparing their readings to the standard curve. Normalize the results to the total protein concentration of the lysate.

Expertise Behind the Protocol: The inclusion of BHT during cell lysis is a critical step to ensure the integrity of the assay. Without it, lipids can undergo peroxidation after cell disruption, leading to artificially inflated MDA levels and inaccurate results.[\[10\]](#)[\[14\]](#)

## References

- Gutterer, B., et al. (2017). 5,6- $\delta$ -DHTL, a stable metabolite of arachidonic acid, is a potential EDHF that mediates microvascular dilation. *Free Radical Biology and Medicine*.
- Shevchenko, A., et al. (1987). [Synthesis of (8Z,11Z,14Z)-eicosatrien-5-ynoic (5,6-dehydroarachidonic) acid and its transformation into [5,6-3H]arachidonic acid and [5,6-3H]prostaglandins E2 and F2 alpha]. *Bioorganicheskaia Khimiia*. Available at: [\[Link\]](#)
- Stark, A. H. (2000). Safety considerations of polyunsaturated fatty acids. *The American Journal of Clinical Nutrition*. Available at: [\[Link\]](#)
- Nair, D. G., & Funk, C. D. (2009). A cell-based assay for screening lipoxygenase inhibitors. *Prostaglandins & Other Lipid Mediators*. Available at: [\[Link\]](#)

- Northwest Life Science Specialties. (n.d.). Lipid Peroxidation Assay. Product Manual. Available at: [\[Link\]](#)
- Assay Genie. (n.d.). Lipoxygenase Activity Assay Kit (Fluorometric) (#BN01136). Product Manual. Available at: [\[Link\]](#)
- Eagle Biosciences. (n.d.). Lipid Peroxidation Assay. Product Manual. Available at: [\[Link\]](#)
- JoVE. (n.d.). Cytochrome P450-Mediated Metabolic Stability Assay in Liver Microsomes. JoVE Protocol. Available at: [\[Link\]](#)
- G-Biosciences. (n.d.). Lipid Peroxidation (LPO) Assay. Product Manual. Available at: [\[Link\]](#)
- Academic Journals. (2008). In vitro 5-Lipoxygenase inhibition of polyphenolic antioxidants from undomesticated plants of South Africa. Journal of Medicinal Plants Research. Available at: [\[Link\]](#)
- Raman, K., et al. (2022). Label-free chemical imaging of cytochrome P450 activity by Raman microscopy. Scientific Reports. Available at: [\[Link\]](#)
- Creative Bioarray. (n.d.). 5-Lipoxygenase Activity Assay Kit. Creative Bioarray Product Information. Available at: [\[Link\]](#)
- Charles River Laboratories. (n.d.). Assays for CYP450 Inhibition, Induction, and Phenotyping. Charles River Laboratories Service Information. Available at: [\[Link\]](#)
- ResearchGate. (n.d.). Cytochrome P450 Inhibition Assay Using Human Liver Microsomes. ResearchGate Publication. Available at: [\[Link\]](#)
- Guengerich, F. P. (2009). Measurement of cytochrome P450 and NADPH–cytochrome P450 reductase. Nature Protocols. Available at: [\[Link\]](#)
- Khan, I., et al. (2024). In vitro 5-LOX inhibitory and antioxidant potential of isoxazole derivatives. PLOS ONE. Available at: [\[Link\]](#)
- CABI Digital Library. (n.d.). In vitro lipoxygenase and hemolysis inhibition by polyphenolic antioxidants from tropical green leafy vegetables. CABI Digital Library Publication. Available

at: [\[Link\]](#)

- SciSpace. (n.d.). Lipid peroxidation and the thiobarbituric acid assay: standardization of the assay when using saturated and unsaturated fatty ac. SciSpace Publication. Available at: [\[Link\]](#)
- IntechOpen. (2022). In Vitro Drug Metabolism Studies Using Human Liver Microsomes. IntechOpen Book Chapter. Available at: [\[Link\]](#)
- Cyberlipid. (n.d.). Acetylenic Fatty Acids. Cyberlipid Resource. Available at: [\[Link\]](#)
- Heikkila, R. E., et al. (1970). Stability of fatty acid monolayers and the relationship between equilibrium spreading pressure, phase transformations, and polymorphic crystal forms. Journal of Lipid Research. Available at: [\[Link\]](#)
- Organic Syntheses. (n.d.). Working with Hazardous Chemicals. Organic Syntheses Resource. Available at: [\[Link\]](#)
- PubMed. (1987). [Synthesis of (8Z,11Z,14Z)-eicosatrien-5-ynoic (5,6-dehydroarachidonic) acid and its transformation into [5,6-3H]arachidonic acid and [5,6-3H]prostaglandins E2 and F2 alpha]. PubMed Abstract. Available at: [\[Link\]](#)
- PubMed. (1970). Stability of fatty acid monolayers and the relationship between equilibrium spreading pressure, phase transformations, and polymorphic crystal forms. PubMed Abstract. Available at: [\[Link\]](#)
- PubMed. (2017). 5,6- $\delta$ -DHTL, a stable metabolite of arachidonic acid, is a potential EDHF that mediates microvascular dilation. PubMed Abstract. Available at: [\[Link\]](#)
- Wang, C., et al. (2023). Preparation of fatty acid solutions for investigating lipid signaling, metabolism, and lipid droplets. Lipids in Health and Disease. Available at: [\[Link\]](#)
- Organic Syntheses. (n.d.). Working with Hazardous Chemicals. Organic Syntheses Resource. Available at: [\[Link\]](#)
- Kim, K. S., et al. (2013). Fatty Acid Composition as a Predictor for the Oxidation Stability of Korean Vegetable Oils with or without Induced Oxidative Stress. Preventive Nutrition and

Food Science. Available at: [\[Link\]](#)

### Need Custom Synthesis?

BenchChem offers custom synthesis for rare earth carbides and specific isotopic labeling.

Email: [info@benchchem.com](mailto:info@benchchem.com) or [Request Quote Online](#).

## Sources

- [1. benchchem.com \[benchchem.com\]](https://www.benchchem.com)
- [2. bio-protocol.org \[bio-protocol.org\]](https://www.bio-protocol.org)
- [3. reactionbiology.com \[reactionbiology.com\]](https://www.reactionbiology.com)
- [4. Cytochrome P450-Mediated Metabolic Stability Assay in Liver Microsomes | Springer Nature Experiments \[experiments.springernature.com\]](#)
- [5. Label-free chemical imaging of cytochrome P450 activity by Raman microscopy - PMC \[pmc.ncbi.nlm.nih.gov\]](#)
- [6. globalresearchonline.net \[globalresearchonline.net\]](https://www.globalresearchonline.net)
- [7. 5,6- \$\delta\$ -DHTL, a stable metabolite of arachidonic acid, is a potential EDHF that mediates microvascular dilation - PubMed \[pubmed.ncbi.nlm.nih.gov\]](#)
- [8. researchgate.net \[researchgate.net\]](https://www.researchgate.net)
- [9. In Vitro Drug Metabolism Studies Using Human Liver Microsomes | IntechOpen \[intechopen.com\]](#)
- [10. researchgate.net \[researchgate.net\]](https://www.researchgate.net)
- [11. file.selleckchem.com \[file.selleckchem.com\]](https://file.selleckchem.com)
- [12. academicjournals.org \[academicjournals.org\]](https://academicjournals.org)
- [13. pdf.benchchem.com \[pdf.benchchem.com\]](https://pdf.benchchem.com)
- [14. eaglebio.com \[eaglebio.com\]](https://www.eaglebio.com)
- To cite this document: BenchChem. [Application Notes and Protocols for 5,6-Dehydroarachidonic Acid]. BenchChem, [2026]. [Online PDF]. Available at: [\[https://www.benchchem.com/product/b10795301/docs#application-notes-and-protocols-for-5-6-dehydroarachidonic-acid\]](https://www.benchchem.com/product/b10795301/docs#application-notes-and-protocols-for-5-6-dehydroarachidonic-acid)

**Disclaimer & Data Validity:**

The information provided in this document is for Research Use Only (RUO) and is strictly not intended for diagnostic or therapeutic procedures. While BenchChem strives to provide accurate protocols, we make no warranties, express or implied, regarding the fitness of this product for every specific experimental setup.

**Technical Support:** The protocols provided are for reference purposes. Unsure if this reagent suits your experiment?

**Need Industrial/Bulk Grade?** [Request Custom Synthesis Quote](#)

## BenchChem

Our mission is to be the trusted global source of essential and advanced chemicals, empowering scientists and researchers to drive progress in science and industry.

### Contact

Address: 3281 E Guasti Rd  
Ontario, CA 91761, United States  
Phone: (601) 213-4426  
Email: [info@benchchem.com](mailto:info@benchchem.com)

[Contact our Ph.D. Support Team for a compatibility check](#)