

# Identifying and minimizing off-target effects of FIIN-1

**Author:** BenchChem Technical Support Team. **Date:** April 2026

## Compound of Interest

Compound Name: FIIN-1  
Cat. No.: B10783074

[Get Quote](#)

## Technical Support Center: FIIN-1

This technical support center provides researchers, scientists, and drug development professionals with comprehensive guidance on identifying and minimizing the off-target effects of **FIIN-1**, a potent and irreversible inhibitor of the Fibroblast Growth Factor Receptor (FGFR) family.

## Frequently Asked Questions (FAQs)

Q1: What is the primary mechanism of action of **FIIN-1**?

A1: **FIIN-1** is a potent, irreversible, and selective inhibitor of the FGFR family of receptor tyrosine kinases (FGFR1, FGFR2, FGFR3, and FGFR4).[1] It forms a covalent bond with a conserved cysteine residue within the ATP-binding pocket of the FGFR kinase domain, leading to the irreversible inactivation of the receptor and blockade of downstream signaling pathways. [2][3]

Q2: What are the known on-target effects of **FIIN-1**?

A2: By inhibiting FGFR signaling, **FIIN-1** can potently block the proliferation of cancer cell lines that are dependent on aberrant FGFR activity.[2] It has been shown to inhibit iFGFR1 autophosphorylation and the phosphorylation of its downstream effectors, such as Erk1/2.[1][2]

Q3: What are the known off-target effects of **FIIN-1**?

A3: While **FIIN-1** is highly selective for the FGFR family, it has been shown to bind to and inhibit other kinases, albeit with lower potency. These include members of the VEGFR family (Flt1/VEGFR1, Flt4/VEGFR3, VEGFR2), as well as BLK, ERK5, KIT, MET, and PDGFRB.[1][2] It is crucial to consider these off-target activities when interpreting experimental results.

Q4: How can I determine if the observed phenotype in my experiment is an on-target or off-target effect of **FIIN-1**?

A4: Differentiating between on-target and off-target effects is critical for validating experimental findings. Several strategies can be employed:

- Use a structurally different FGFR inhibitor: If a different, structurally unrelated FGFR inhibitor produces the same phenotype, it is more likely to be an on-target effect.
- Rescue experiments: Transfecting cells with a drug-resistant mutant of the target FGFR should rescue the on-target effects but not the off-target effects.[4]
- Dose-response analysis: On-target effects should typically occur at lower concentrations of **FIIN-1**, consistent with its high potency for FGFRs. Off-target effects may only appear at higher concentrations.
- Knockdown/knockout studies: Using techniques like siRNA or CRISPR to reduce the expression of the intended FGFR target should phenocopy the effects of **FIIN-1** if they are on-target.

## Troubleshooting Guide

Issue	Potential Cause	Recommended Action
<p>Unexpected or inconsistent cellular phenotype.</p>	<p>Off-target effects: FIIN-1 may be inhibiting other kinases in your cellular model, leading to confounding results.</p>	<p>1. Perform a kinome-wide selectivity screen to identify other potential targets of FIIN-1 in your system. 2. Validate off-target engagement in cells using methods like Cellular Thermal Shift Assay (CETSA) or NanoBRET assays.<a href="#">[5]</a> 3. Lower the concentration of FIIN-1 to a range where it is most selective for FGFRs.</p>
<p>High levels of cytotoxicity observed at effective concentrations.</p>	<p>On-target toxicity: The observed cytotoxicity may be a direct result of inhibiting the intended FGFR target in your specific cell line. Off-target toxicity: Cytotoxicity could be due to the inhibition of other essential kinases.</p>	<p>1. Confirm on-target engagement at the cytotoxic concentrations using Western blotting to assess the phosphorylation status of downstream FGFR effectors like Erk1/2.<a href="#">[2]</a> 2. Test FIIN-1 on a control cell line that does not depend on FGFR signaling. 3. Perform a kinome scan to identify potential off-target kinases that could be responsible for the toxicity.<a href="#">[4]</a></p>
<p>Lack of correlation between biochemical potency and cellular activity.</p>	<p>Poor cell permeability: FIIN-1 may not be efficiently entering the cells. Drug efflux: The compound may be actively transported out of the cells by efflux pumps. Cellular environment: High intracellular ATP concentrations can compete with FIIN-1 for binding to the kinase.</p>	<p>1. Assess cell permeability using standard assays. 2. Co-administer with efflux pump inhibitors to see if cellular activity is restored. 3. Perform cellular target engagement assays like CETSA to confirm that FIIN-1 is binding to FGFR in the cellular environment.<a href="#">[5]</a> <a href="#">[6]</a></p>

## Quantitative Data Summary

Table 1: Biochemical Potency of **FIIN-1** Against On-Target FGFRs

Kinase	Kd (nM)	IC50 (nM)
FGFR1	2.8[1][2]	9.2[1][2]
FGFR2	6.9[1][2]	6.2[1][2]
FGFR3	5.4[1][2]	11.9[1][2]
FGFR4	120[1][2]	189[1][2]

Table 2: Biochemical Potency of **FIIN-1** Against Known Off-Target Kinases

Kinase	Kd (nM)	IC50 (nM)
Flt1 (VEGFR1)	32[1][2]	661[1][2]
Flt4 (VEGFR3)	120	-
VEGFR2	210	-
BLK	65[2]	381[1][2]
ERK5	160[1]	-
KIT	420[1]	-
MET	1000[1]	-
PDGFRB	480[1]	-

## Signaling Pathways and Experimental Workflows

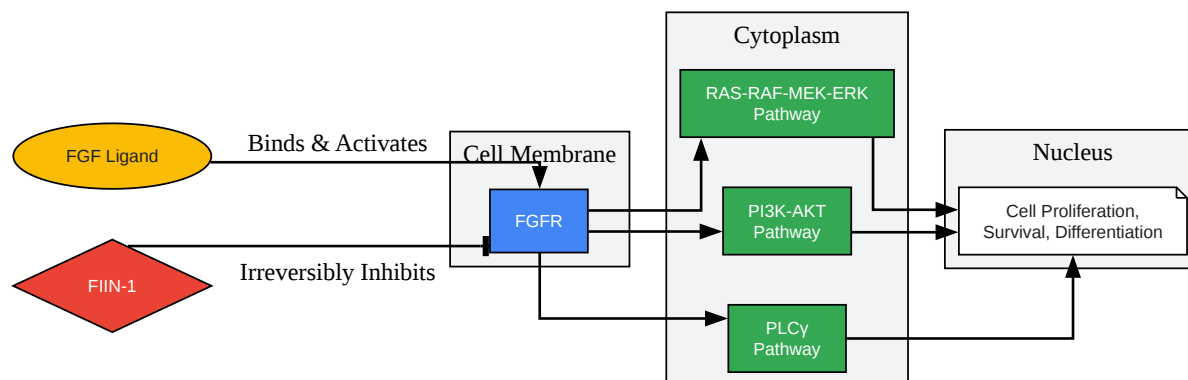

[Click to download full resolution via product page](#)

Caption: On-target signaling pathway of **FIIN-1**.



[Click to download full resolution via product page](#)

Caption: Workflow for identifying off-target effects of **FIIN-1**.

## Key Experimental Protocols

### Kinome Profiling

Objective: To determine the selectivity of **FIIN-1** by screening it against a large panel of kinases.[4]

#### Methodology:

- **Compound Preparation:** Prepare **FIIN-1** at a concentration significantly higher than its on-target IC50 (e.g., 1  $\mu$ M) to identify potential off-targets.
- **Kinase Panel:** Utilize a commercially available kinase profiling service that offers a broad panel of purified human kinases (e.g., Eurofins DiscoverX KINOMEScan™, Reaction Biology Corporation).
- **Binding Assay:** The service will typically perform a competition binding assay where **FIIN-1** competes with a labeled ligand for binding to each kinase in the panel.
- **Data Analysis:** The results are usually provided as a percentage of control, indicating the degree of inhibition for each kinase. Potent off-targets are identified as those with significant inhibition. Follow-up with dose-response curves to determine the IC50 or Kd for any identified hits.

## Cellular Thermal Shift Assay (CETSA)

**Objective:** To confirm the engagement of **FIIN-1** with its on-target (FGFR) and potential off-target kinases within a cellular context.<sup>[5][6]</sup>

#### Methodology:

- **Cell Treatment:** Treat intact cells with either vehicle control (e.g., DMSO) or a specific concentration of **FIIN-1** for a designated time.
- **Heating:** Aliquot the cell suspensions and heat them to a range of temperatures for a set duration (e.g., 3-7 minutes).
- **Cell Lysis:** Lyse the cells to release the cellular proteins.
- **Separation of Soluble and Aggregated Proteins:** Centrifuge the lysates to pellet the aggregated, denatured proteins.
- **Protein Analysis:** Collect the supernatant containing the soluble proteins and analyze the levels of the target protein (FGFR or potential off-target) using Western blotting or other protein detection methods.

- **Data Analysis:** A shift in the melting curve of the protein in the presence of **FIIN-1** indicates target engagement. Ligand binding stabilizes the protein, resulting in it remaining soluble at higher temperatures compared to the vehicle-treated control.

## Quantitative Proteomics for Off-Target Identification

Objective: To globally identify the cellular proteins that interact with **FIIN-1** in an unbiased manner.<sup>[7][8][9]</sup>

Methodology:

- **Chemical Probe Synthesis:** Synthesize a chemical probe version of **FIIN-1** that incorporates a clickable handle (e.g., an alkyne or azide group) and a photo-affinity label.
- **Live Cell Labeling:** Treat live cells with the **FIIN-1** chemical probe.
- **UV Crosslinking:** If using a photo-affinity probe, irradiate the cells with UV light to covalently link the probe to its binding partners.
- **Cell Lysis and Click Chemistry:** Lyse the cells and perform a click reaction to attach a reporter tag (e.g., biotin) to the probe-bound proteins.
- **Affinity Purification:** Use affinity purification (e.g., streptavidin beads for biotin-tagged proteins) to enrich the proteins that interacted with the **FIIN-1** probe.
- **Mass Spectrometry:** Elute the enriched proteins and identify them using liquid chromatography-mass spectrometry (LC-MS/MS).
- **Data Analysis:** Analyze the mass spectrometry data to identify proteins that were significantly enriched in the probe-treated samples compared to controls. These are potential on- and off-targets of **FIIN-1**.

### Need Custom Synthesis?

BenchChem offers custom synthesis for rare earth carbides and specific isotopic labeling.

Email: [info@benchchem.com](mailto:info@benchchem.com) or [Request Quote Online](#).

## References

- [1. medchemexpress.com \[medchemexpress.com\]](https://www.medchemexpress.com)
- [2. A Structure-guided Approach to Creating Covalent FGFR Inhibitors - PMC \[pmc.ncbi.nlm.nih.gov\]](https://pubmed.ncbi.nlm.nih.gov/)
- [3. Pharmacological and Biological Targeting of FGFR1 in Cancer - PMC \[pmc.ncbi.nlm.nih.gov\]](https://pubmed.ncbi.nlm.nih.gov/)
- [4. benchchem.com \[benchchem.com\]](https://www.benchchem.com)
- [5. benchchem.com \[benchchem.com\]](https://www.benchchem.com)
- [6. Cellular thermal shift and clickable chemical probe assays for the determination of drug-target engagement in live cells - Organic & Biomolecular Chemistry \(RSC Publishing\) \[pubs.rsc.org\]](https://pubs.rsc.org/)
- [7. Proteome-wide Identification of Off-Targets of a Potent EGFR L858R/T790M Mutant Inhibitor - PMC \[pmc.ncbi.nlm.nih.gov\]](https://pubmed.ncbi.nlm.nih.gov/)
- [8. Quantitative Proteomics Reveals Cellular Off-Targets of a DDR1 Inhibitor - PMC \[pmc.ncbi.nlm.nih.gov\]](https://pubmed.ncbi.nlm.nih.gov/)
- [9. researchgate.net \[researchgate.net\]](https://www.researchgate.net)
- To cite this document: BenchChem. [Identifying and minimizing off-target effects of FIIN-1]. BenchChem, [2026]. [Online PDF]. Available at: [\[https://www.benchchem.com/product/b10783074/docs#identifying-and-minimizing-off-target-effects-of-fiin-1\]](https://www.benchchem.com/product/b10783074/docs#identifying-and-minimizing-off-target-effects-of-fiin-1)

---

### Disclaimer & Data Validity:

The information provided in this document is for Research Use Only (RUO) and is strictly not intended for diagnostic or therapeutic procedures. While BenchChem strives to provide accurate protocols, we make no warranties, express or implied, regarding the fitness of this product for every specific experimental setup.

**Technical Support:** The protocols provided are for reference purposes. Unsure if this reagent suits your experiment?

**Need Industrial/Bulk Grade?** [Request Custom Synthesis Quote](#)

# BenchChem

Our mission is to be the trusted global source of essential and advanced chemicals, empowering scientists and researchers to drive progress in science and industry.

## Contact

Address: 3281 E Guasti Rd

Ontario, CA 91761, United States

Phone: (601) 213-4426

Email: [info@benchchem.com](mailto:info@benchchem.com)

[Contact our Ph.D. Support Team for a compatibility check](#)