

The Cellular Odyssey of IQGAP3: An In-Vitro Perspective on Localization and Distribution

Author: BenchChem Technical Support Team. **Date:** April 2026

Compound of Interest

Compound Name: IQ-3
Cat. No.: B10782973

[Get Quote](#)

For Researchers, Scientists, and Drug Development Professionals

Introduction

IQGAP3, an integral member of the IQ motif-containing GTPase-activating protein family, has emerged as a critical scaffolding protein in cellular signaling, with profound implications in oncogenesis. Often referred to as **IQ-3** in literature, this protein is a key orchestrator of pathways that govern cell proliferation, migration, and cytoskeletal dynamics. This technical guide provides a comprehensive overview of the in-vitro cellular localization and distribution of IQGAP3, offering insights into its functional roles within the cellular machinery. While the subcellular presence of IQGAP3 is well-documented, it is important to note that precise quantitative data on its relative distribution across different cellular compartments is not extensively available in current literature. This guide, therefore, focuses on its qualitative localization, the signaling pathways it modulates, and the experimental methodologies used to elucidate its cellular distribution.

Data Presentation: Subcellular Localization of IQGAP3

The in-vitro subcellular distribution of IQGAP3 has been primarily characterized through qualitative methods such as immunofluorescence and subcellular fractionation followed by western blotting. These studies have consistently identified IQGAP3 in several key cellular compartments, indicating its multifaceted role in cellular processes.

Cellular Compartment	Presence of IQGAP3	Method of Detection	Associated Functions	Reference Cell Lines
Nucleoplasm	Present	Immunofluorescence, Subcellular Fractionation	Regulation of gene expression, cell cycle progression	A-431 (human epidermal carcinoma), U-2 OS (human osteosarcoma), various breast cancer cell lines
Cytoplasm	Present	Immunofluorescence, Subcellular Fractionation	Scaffolding for signaling cascades, cytoskeletal interactions	Keratinocytes, Pancreatic ductal adenocarcinoma cells, High-grade serous ovarian cancer cells
Plasma Membrane	Present (Concentrated)	Immunofluorescence, Subcellular Fractionation	Cell-cell adhesion, receptor signaling	Keratinocytes, High-grade serous ovarian cancer cells

Experimental Protocols

Immunofluorescence Staining for IQGAP3 Localization

This protocol outlines the steps for visualizing the subcellular localization of IQGAP3 in cultured cells using immunofluorescence microscopy.

Materials:

- Cultured cells on glass coverslips

- Phosphate-buffered saline (PBS)
- 4% Paraformaldehyde (PFA) in PBS for fixation
- 0.1% Triton X-100 in PBS for permeabilization
- Blocking buffer (e.g., 5% Bovine Serum Albumin in PBS)
- Primary antibody against IQGAP3
- Fluorophore-conjugated secondary antibody
- DAPI (4',6-diamidino-2-phenylindole) for nuclear counterstaining
- Antifade mounting medium
- Fluorescence microscope

Procedure:

- Cell Culture and Fixation:
 - Seed cells on sterile glass coverslips in a petri dish and culture until desired confluency.
 - Wash the cells gently with PBS.
 - Fix the cells by incubating with 4% PFA for 15 minutes at room temperature.
 - Wash three times with PBS.
- Permeabilization:
 - Incubate the fixed cells with 0.1% Triton X-100 in PBS for 10 minutes to permeabilize the cell membranes.
 - Wash three times with PBS.
- Blocking:

- Incubate the cells with blocking buffer for 1 hour at room temperature to prevent non-specific antibody binding.
- Primary Antibody Incubation:
 - Dilute the primary anti-IQGAP3 antibody in blocking buffer to the recommended concentration.
 - Incubate the cells with the diluted primary antibody overnight at 4°C in a humidified chamber.
- Secondary Antibody Incubation:
 - Wash the cells three times with PBS.
 - Dilute the fluorophore-conjugated secondary antibody in blocking buffer.
 - Incubate the cells with the diluted secondary antibody for 1 hour at room temperature, protected from light.
- Counterstaining and Mounting:
 - Wash the cells three times with PBS.
 - Incubate with DAPI solution for 5 minutes to stain the nuclei.
 - Wash twice with PBS.
 - Mount the coverslips onto glass slides using antifade mounting medium.
- Imaging:
 - Visualize the stained cells using a fluorescence microscope with appropriate filters for the chosen fluorophores.

Subcellular Fractionation and Western Blotting for IQGAP3 Distribution

This protocol describes the separation of cellular components into nuclear, cytoplasmic, and membrane fractions to determine the relative abundance of IQGAP3 in each compartment by Western blotting.

Materials:

- Cultured cells
- PBS
- Hypotonic lysis buffer
- Detergent-based lysis buffer (e.g., RIPA buffer)
- Nuclear extraction buffer
- Dounce homogenizer or syringe with a narrow-gauge needle
- Centrifuge and ultracentrifuge
- Protein assay kit (e.g., BCA assay)
- SDS-PAGE gels and electrophoresis apparatus
- PVDF membrane
- Transfer apparatus
- Blocking buffer (e.g., 5% non-fat milk in TBST)
- Primary antibody against IQGAP3
- HRP-conjugated secondary antibody
- Chemiluminescent substrate
- Imaging system

Procedure:

- Cell Harvesting and Lysis:
 - Harvest cultured cells and wash with ice-cold PBS.
 - Resuspend the cell pellet in hypotonic lysis buffer and incubate on ice to swell the cells.
 - Lyse the cells by passing them through a narrow-gauge needle or using a Dounce homogenizer.
- Fractionation by Centrifugation:
 - Nuclear Fraction: Centrifuge the lysate at a low speed (e.g., 1,000 x g) to pellet the nuclei. Wash the nuclear pellet and resuspend in nuclear extraction buffer.
 - Cytoplasmic and Membrane Fractions: Transfer the supernatant from the previous step to a new tube and centrifuge at a higher speed (e.g., 100,000 x g) in an ultracentrifuge. The resulting supernatant is the cytoplasmic fraction, and the pellet contains the membrane fraction. Resuspend the membrane pellet in a suitable buffer.
- Protein Quantification:
 - Determine the protein concentration of each fraction using a protein assay kit.
- Western Blotting:
 - Normalize the protein amounts for each fraction and prepare samples for SDS-PAGE.
 - Separate the proteins by SDS-PAGE and transfer them to a PVDF membrane.
 - Block the membrane with blocking buffer for 1 hour.
 - Incubate the membrane with the primary anti-IQGAP3 antibody overnight at 4°C.
 - Wash the membrane and incubate with the HRP-conjugated secondary antibody for 1 hour.
 - Wash the membrane again and add the chemiluminescent substrate.

- Capture the signal using an imaging system. Densitometry analysis can be performed to semi-quantify the relative abundance of IQGAP3 in each fraction.

Mandatory Visualizations

Signaling Pathways Involving IQGAP3

IQGAP3 acts as a critical scaffold, integrating signals from multiple pathways to regulate cell proliferation and migration. Key among these are the RAS/ERK and TGF- β signaling cascades.

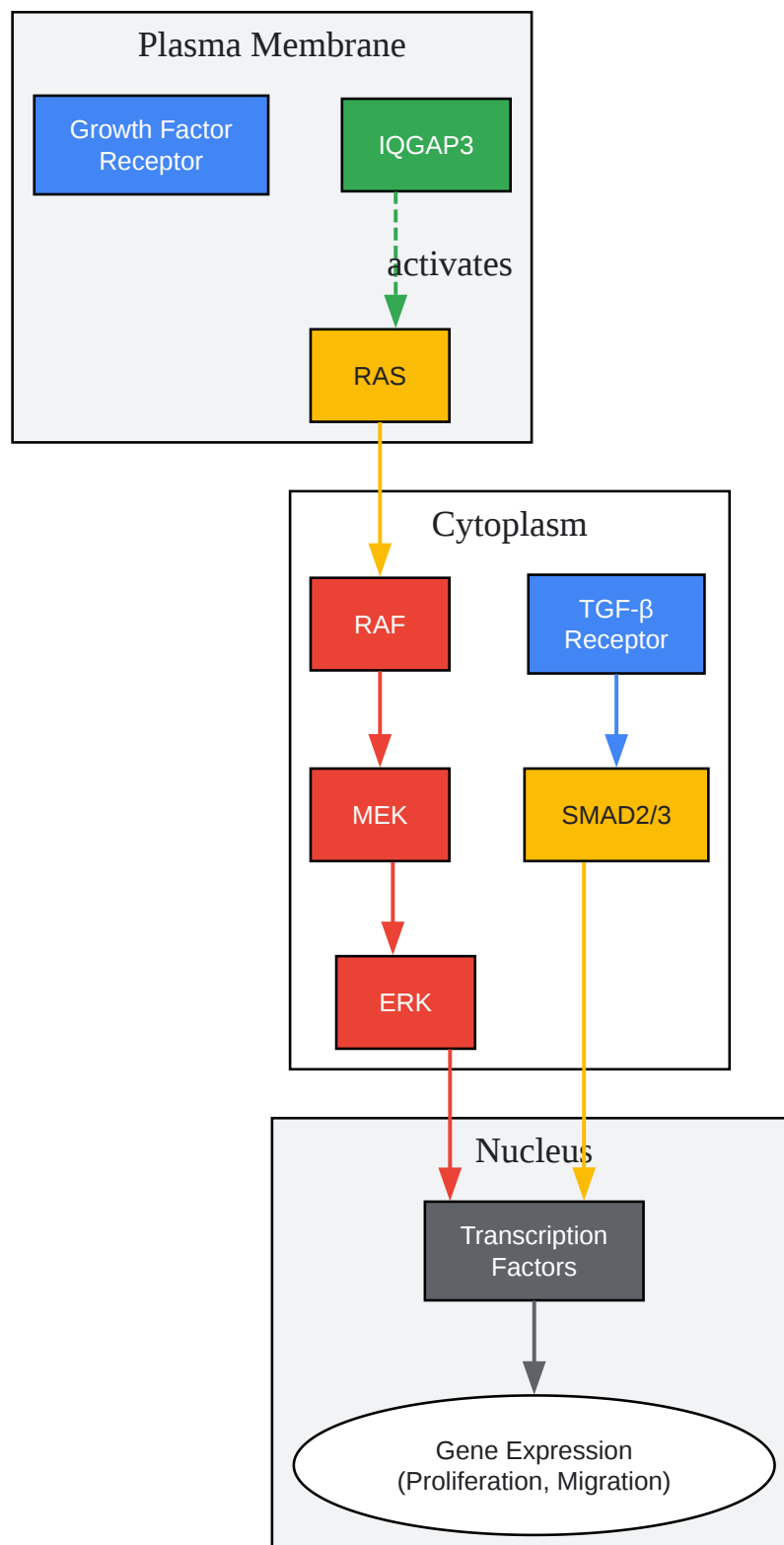

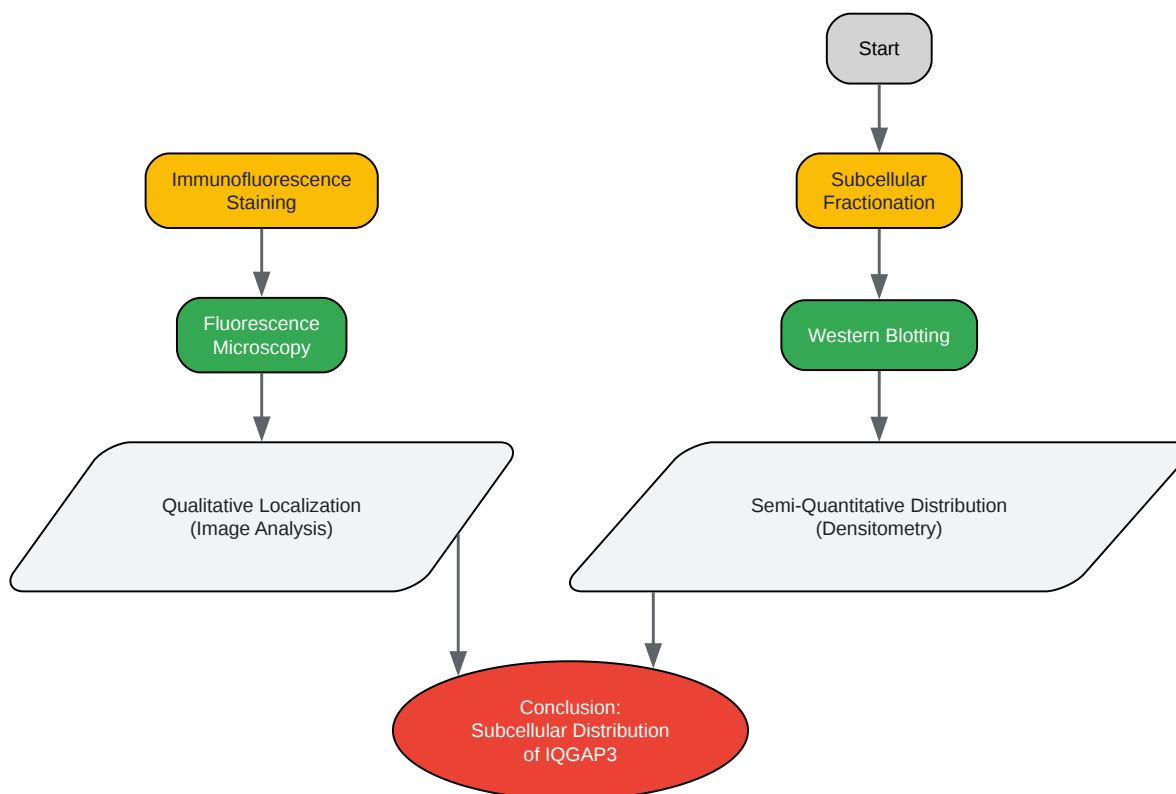

[Click to download full resolution via product page](#)

- To cite this document: BenchChem. [The Cellular Odyssey of IQGAP3: An In-Vitro Perspective on Localization and Distribution]. BenchChem, [2026]. [Online PDF]. Available at: [<https://www.benchchem.com/product/b10782973/docs#the-cellular-odyssey-of-iqgap3-an-in-vitro-perspective-on-localization-and-distribution>]

Disclaimer & Data Validity:

The information provided in this document is for Research Use Only (RUO) and is strictly not intended for diagnostic or therapeutic procedures. While BenchChem strives to provide accurate protocols, we make no warranties, express or implied, regarding the fitness of this product for every specific experimental setup.

Technical Support: The protocols provided are for reference purposes. Unsure if this reagent suits your experiment?

Need Industrial/Bulk Grade? [Request Custom Synthesis Quote](#)

BenchChem

Our mission is to be the trusted global source of essential and advanced chemicals, empowering scientists and researchers to drive progress in science and industry.

Contact

Address: 3281 E Guasti Rd

Ontario, CA 91761, United States

Phone: (601) 213-4426

Email: info@benchchem.com

[Contact our Ph.D. Support Team for a compatibility check](#)