

Technical Support Center: Troubleshooting JJKK 048 Off-Target Effects

Author: BenchChem Technical Support Team. **Date:** April 2026

Compound of Interest

Compound Name: JJKK 048
Cat. No.: B10782722

[Get Quote](#)

This technical support center provides guidance for researchers, scientists, and drug development professionals encountering potential off-target effects while using the potent and selective monoacylglycerol lipase (MAGL) inhibitor, **JJKK 048**. The information is presented in a question-and-answer format to directly address common experimental issues.

Frequently Asked Questions (FAQs)

Q1: We are observing a phenotype in our cell-based assay that is inconsistent with the known function of MAGL. Could this be an off-target effect of **JJKK 048**?

A1: While **JJKK 048** is a highly selective inhibitor of MAGL, unexpected phenotypes can occur. [1] Off-target effects are a possibility with any small molecule inhibitor. The primary known off-target of **JJKK 048** is α/β -hydrolase domain 6 (ABHD6), though with significantly lower potency. To investigate if the observed phenotype is due to an off-target effect, consider the following:

- Dose-response analysis: Determine if the potency of **JJKK 048** for the unexpected phenotype differs significantly from its potency for MAGL inhibition ($IC_{50} \approx 0.4$ nM). A large discrepancy may suggest an off-target effect.

- Use a structurally different MAGL inhibitor: If a structurally unrelated MAGL inhibitor recapitulates the phenotype, it is more likely to be an on-target effect.
- Rescue experiment: If possible, overexpress a resistant mutant of MAGL. If the phenotype is not rescued, it points towards an off-target mechanism.
- Investigate the role of ABHD6: As the primary known off-target, consider if inhibition of ABHD6 could explain the observed phenotype. Use an ABHD6-selective inhibitor, such as WWL70, to see if it produces a similar effect.[2]

Q2: Our in vivo experiments with **JJKK 048** are showing effects that are not blocked by a cannabinoid receptor 1 (CB1) antagonist, even though MAGL inhibition is expected to increase the endocannabinoid 2-arachidonoylglycerol (2-AG). Why might this be?

A2: This is an important observation. While the primary signaling outcome of MAGL inhibition is the potentiation of endocannabinoid signaling through increased 2-AG levels, which primarily acts on CB1 and CB2 receptors, not all effects of MAGL inhibition are necessarily mediated by these receptors. MAGL inhibition also alters the downstream metabolic products of 2-AG. Specifically, it reduces the production of arachidonic acid (AA), a precursor for pro-inflammatory prostaglandins. Therefore, some of the observed in vivo effects could be due to the reduction in prostaglandin signaling, which would not be blocked by a CB1 antagonist. It is also possible that very high local concentrations of 2-AG could have effects independent of CB1/CB2 receptors.

Q3: We are seeing unexpected toxicity in our cell cultures at concentrations where we expect to see specific MAGL inhibition. What could be the cause?

A3: Cellular toxicity can arise from on-target or off-target effects, or from experimental artifacts. To dissect this:

- Confirm on-target engagement: Use a Cellular Thermal Shift Assay (CETSA) to confirm that **JJKK 048** is engaging with MAGL at the concentrations used in your experiments.
- Assess cell line dependency: Test the toxicity of **JJKK 048** in a cell line that does not express MAGL. If the toxicity persists, it is likely an off-target effect.

- Evaluate the contribution of ABHD6 inhibition: ABHD6 has been implicated in various cellular processes, and its inhibition could potentially lead to toxicity in certain cell types.
- Consider compound solubility and aggregation: At higher concentrations, small molecules can sometimes come out of solution and form aggregates, which can cause non-specific cellular stress and toxicity. Ensure that **JJKK 048** is fully solubilized in your culture medium at the concentrations being tested.

Data Presentation

JJKK 048 is characterized by its high potency for MAGL and significant selectivity over other related enzymes.

Target	IC50 (nM)	Selectivity vs. MAGL	Reference
MAGL (human)	0.4	-	
FAAH (human)	>5200	>13,000-fold	
ABHD6 (human)	~252	~630-fold	

Experimental Protocols

To experimentally investigate potential off-target effects of **JJKK 048**, the following methodologies are recommended.

Cellular Thermal Shift Assay (CETSA) for Target Engagement

CETSA is a powerful method to verify the direct binding of a compound to its target in a cellular environment. The principle is that ligand binding stabilizes the target protein, leading to a higher melting temperature.

Protocol:

- Cell Treatment: Culture cells to 70-80% confluency. Treat cells with either vehicle (e.g., DMSO) or **JJKK 048** at the desired concentration for 1-2 hours at 37°C.

- **Harvest and Resuspend:** Harvest the cells, wash with PBS, and resuspend the cell pellet in PBS containing protease inhibitors.
- **Heating:** Aliquot the cell suspension into PCR tubes and heat them at a range of temperatures (e.g., 40-70°C) for 3 minutes in a thermal cycler. Include an unheated control.
- **Lysis:** Lyse the cells by three cycles of freeze-thawing (liquid nitrogen and a 37°C water bath).
- **Separation of Soluble and Precipitated Fractions:** Centrifuge the lysates at 20,000 x g for 20 minutes at 4°C to pellet the aggregated proteins.
- **Western Blot Analysis:** Collect the supernatant (soluble fraction) and analyze the amount of soluble MAGL by Western blotting using a specific anti-MAGL antibody.
- **Data Analysis:** Quantify the band intensities and plot the percentage of soluble MAGL as a function of temperature. A shift in the melting curve to a higher temperature in the **JJKK 048**-treated samples indicates target engagement.

Kinome Profiling for Off-Target Kinase Identification

While **JJKK 048** is not a kinase inhibitor, unexpected phenotypes, particularly those related to signaling pathways, can sometimes be caused by off-target effects on kinases. Kinome profiling can screen for such interactions.

Methodology:

- **Lysate Preparation:** Prepare a high-quality cell or tissue lysate from your experimental system treated with either vehicle or **JJKK 048**.
- **Kinase Enrichment:** Use multiplexed inhibitor beads (MIBs) or other affinity matrices to capture a broad range of kinases from the lysate.
- **Elution and Digestion:** Elute the captured kinases and digest them into peptides using trypsin.
- **Mass Spectrometry:** Analyze the peptide mixture by liquid chromatography-tandem mass spectrometry (LC-MS/MS) to identify and quantify the captured kinases.

- Data Analysis: Compare the abundance of kinases captured from the vehicle- and **JJKK 048**-treated lysates. A significant decrease in the capture of a particular kinase in the presence of **JJKK 048** may indicate a direct interaction.

Visualizations

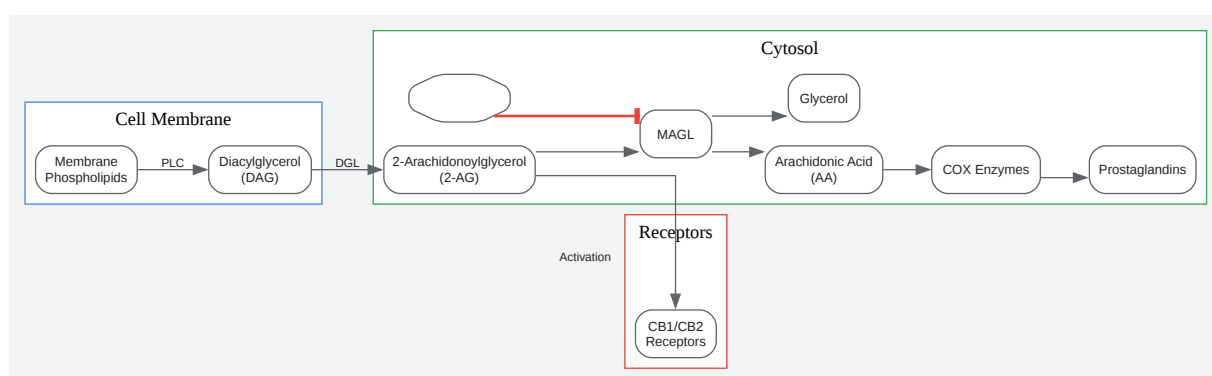

[Click to download full resolution via product page](#)

Caption: Simplified MAGL signaling pathway and the inhibitory action of **JJKK 048**.

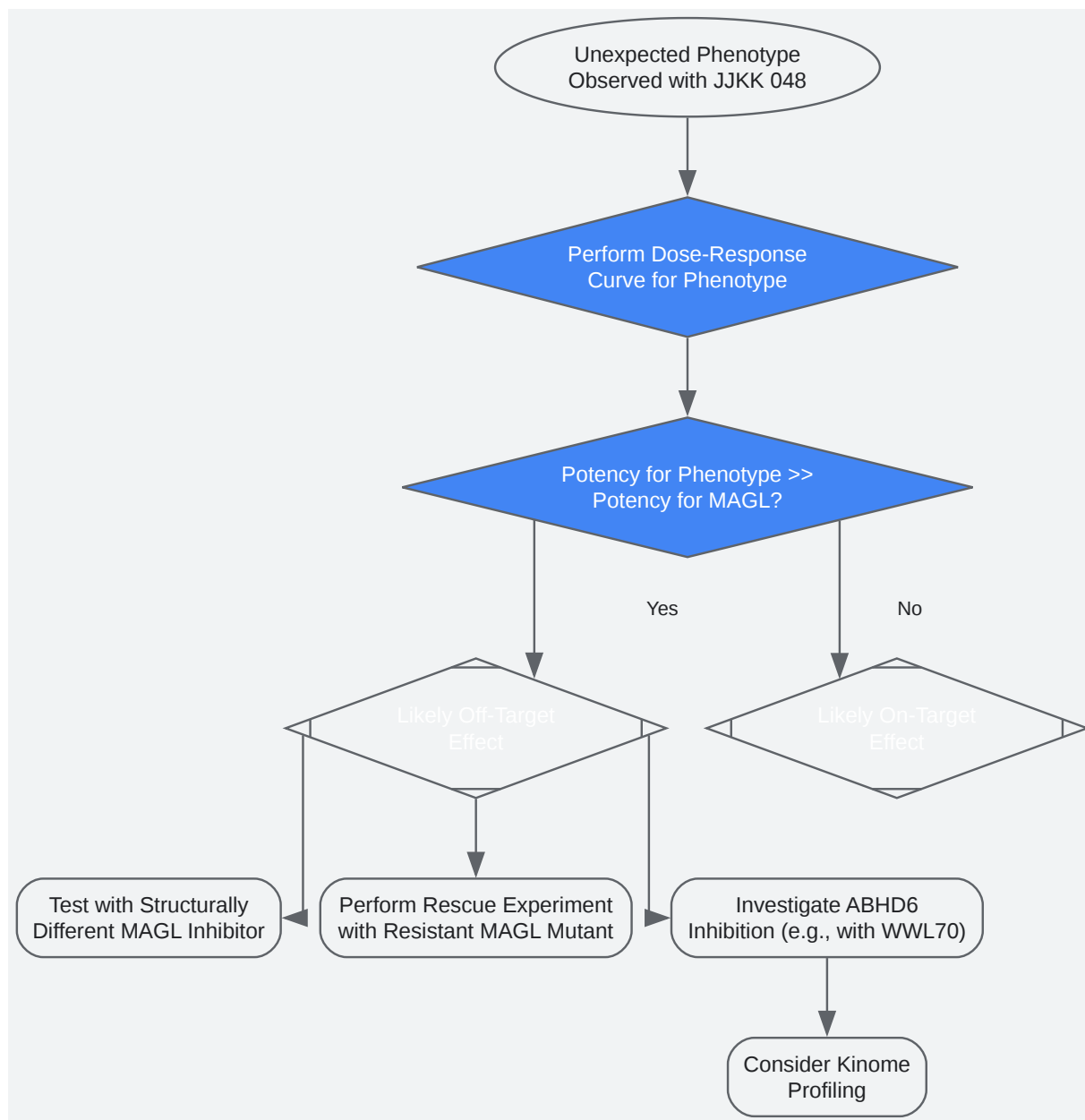

[Click to download full resolution via product page](#)

Caption: Decision tree for troubleshooting unexpected phenotypes with **JJKK 048**.

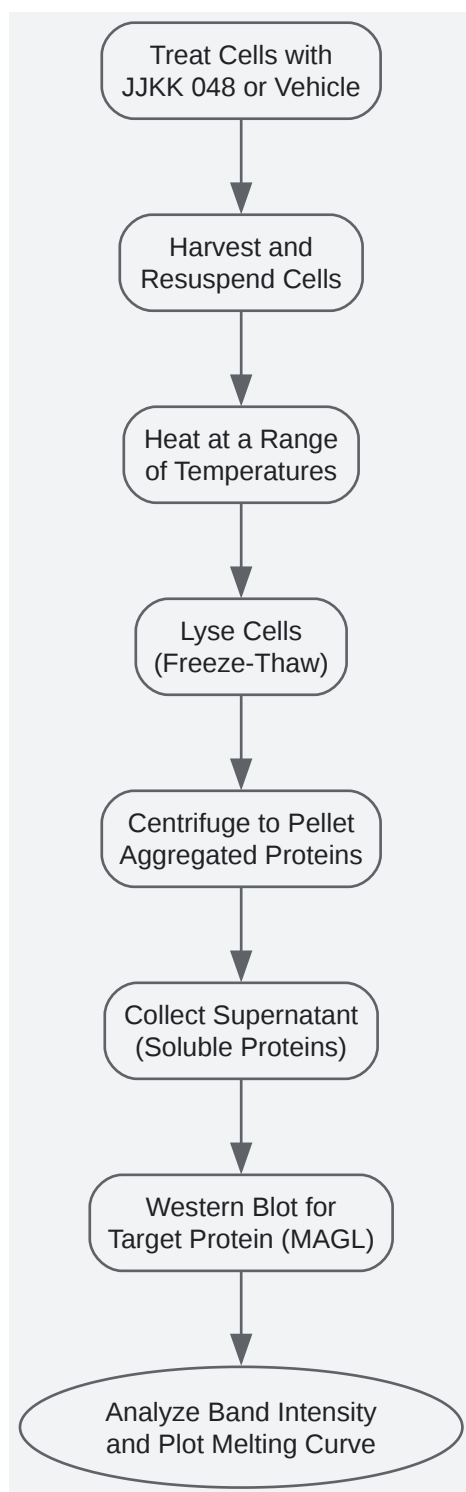

[Click to download full resolution via product page](#)

Caption: Experimental workflow for the Cellular Thermal Shift Assay (CETSA).

Need Custom Synthesis?

BenchChem offers custom synthesis for rare earth carbides and specific isotopic labeling.

Email: info@benchchem.com or [Request Quote Online](#).

References

- [1. medchemexpress.com \[medchemexpress.com\]](https://www.medchemexpress.com)
- [2. medchemexpress.com \[medchemexpress.com\]](https://www.medchemexpress.com)
- To cite this document: BenchChem. [Technical Support Center: Troubleshooting JJKK 048 Off-Target Effects]. BenchChem, [2026]. [Online PDF]. Available at: [\[https://www.benchchem.com/product/b10782722/docs#technical-support-center-troubleshooting-jjkk-048-off-target-effects\]](https://www.benchchem.com/product/b10782722/docs#technical-support-center-troubleshooting-jjkk-048-off-target-effects)

Disclaimer & Data Validity:

The information provided in this document is for Research Use Only (RUO) and is strictly not intended for diagnostic or therapeutic procedures. While BenchChem strives to provide accurate protocols, we make no warranties, express or implied, regarding the fitness of this product for every specific experimental setup.

Technical Support: The protocols provided are for reference purposes. Unsure if this reagent suits your experiment?

Need Industrial/Bulk Grade? [Request Custom Synthesis Quote](#)

BenchChem

Our mission is to be the trusted global source of essential and advanced chemicals, empowering scientists and researchers to drive progress in science and industry.

Contact

Address: 3281 E Guasti Rd

Ontario, CA 91761, United States

Phone: (601) 213-4426

Email: info@benchchem.com

Contact our Ph.D. Support Team for a compatibility check