

# Ex Vivo Analysis of Immune Cell Activation: Application Notes and Protocols

**Author:** BenchChem Technical Support Team. **Date:** April 2026

## Compound of Interest

Compound Name: *STING agonist-15*

Cat. No.: *B10782765*

[Get Quote](#)

For Researchers, Scientists, and Drug Development Professionals

This document provides detailed application notes and protocols for the ex vivo analysis of immune cell activation. It is designed to guide researchers, scientists, and drug development professionals in designing, executing, and interpreting experiments to assess the functional responses of various immune cell populations. The protocols and data presentation formats are structured to facilitate clear comparisons and reproducible results.

## Introduction

Ex vivo analysis of immune cell activation is a critical component of immunology research and drug development. These assays provide valuable insights into the mechanisms of immune responses, the efficacy of immunomodulatory therapies, and the potential for off-target effects. By studying immune cells outside the body, in a controlled environment, researchers can dissect cellular and molecular pathways that are often challenging to investigate in vivo. This document covers key methodologies for activating and analyzing T cells, B cells, monocytes, and dendritic cells, including detailed protocols and data interpretation guidelines.

# Key Methodologies for Ex Vivo Immune Cell Activation Analysis

Several robust techniques are available for the ex vivo assessment of immune cell activation. The choice of method depends on the specific research question, the cell type of interest, and the desired endpoints. The most common techniques include:

- **Enzyme-Linked Immunospot (ELISPOT) Assay:** A highly sensitive method to quantify the frequency of cytokine-secreting cells at a single-cell level.[\[1\]](#)[\[2\]](#)
- **Intracellular Cytokine Staining (ICS) with Flow Cytometry:** Allows for the multiparametric analysis of cytokine production within individual cells, enabling correlation with cell surface markers.[\[3\]](#)[\[4\]](#)[\[5\]](#)[\[6\]](#)
- **Phospho-flow Cytometry:** Measures the phosphorylation status of intracellular signaling proteins, providing insights into the activation state of signaling pathways.[\[7\]](#)[\[8\]](#)[\[9\]](#)[\[10\]](#)
- **Whole Blood Assays:** Utilizes whole blood to assess the global immune response to stimuli, preserving the complex interplay between different cell types.[\[11\]](#)[\[12\]](#)[\[13\]](#)[\[14\]](#)
- **Multiplex Cytokine Bead Array:** Enables the simultaneous measurement of multiple cytokines and chemokines in a small volume of sample.[\[15\]](#)[\[16\]](#)[\[17\]](#)

## Section 1: T Cell Activation Analysis

T cells play a central role in adaptive immunity, and their activation is a key indicator of an immune response. Ex vivo T cell activation can be induced by various stimuli, including antigens, mitogens, and antibodies targeting T cell surface receptors.

## Experimental Workflow: T Cell Activation and Analysis

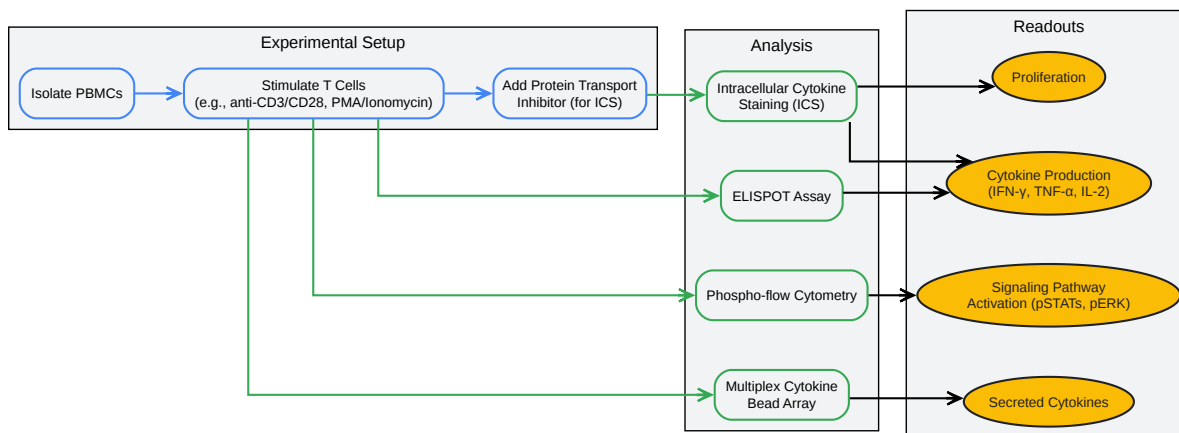

[Click to download full resolution via product page](#)

Caption: Workflow for ex vivo T cell activation and analysis.

## T Cell Receptor (TCR) Signaling Pathway

T cell activation is initiated by the engagement of the T cell receptor (TCR) with a peptide-MHC complex on an antigen-presenting cell (APC).[18][19] This interaction triggers a cascade of intracellular signaling events leading to T cell proliferation, differentiation, and effector functions.[18][20][21]

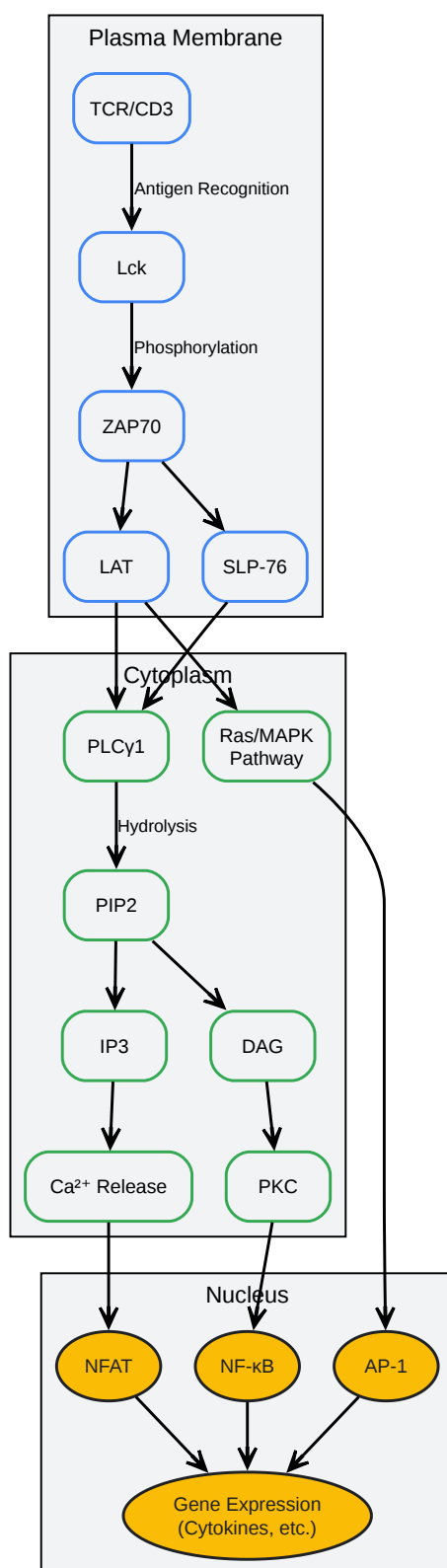

[Click to download full resolution via product page](#)

Caption: Simplified T Cell Receptor (TCR) signaling pathway.

## Quantitative Data Summary: T Cell Cytokine Production

Stimulus	Cell Type	Cytokine	ELISPOT (Spots/10 <sup>6</sup> cells)	ICS (% positive cells)
Anti-CD3/CD28	Human PBMCs	IFN- $\gamma$	500 - 2000	10 - 40%
		TNF- $\alpha$	300 - 1500	8 - 30%
		IL-2	200 - 1000	5 - 20%
PMA/Ionomycin	Human PBMCs	IFN- $\gamma$	1000 - 5000	20 - 60%
		TNF- $\alpha$	800 - 4000	15 - 50%
		IL-2	500 - 2500	10 - 35%
Unstimulated	Human PBMCs	IFN- $\gamma$	< 50	< 1%
		TNF- $\alpha$	< 30	< 1%
		IL-2	< 20	< 0.5%

Note: Values are representative and can vary based on donor, reagents, and experimental conditions.

## Protocol: Intracellular Cytokine Staining for T Cells

Materials:

- Peripheral Blood Mononuclear Cells (PBMCs)
- Cell culture medium (e.g., RPMI-1640 with 10% FBS)
- T cell stimulation reagent (e.g., anti-CD3/CD28 antibodies or PMA/Ionomycin)
- Protein transport inhibitor (e.g., Brefeldin A or Monensin)
- Flow cytometry staining buffer
- Fixation/Permeabilization buffer

- Fluorochrome-conjugated antibodies against cell surface markers (e.g., CD3, CD4, CD8) and intracellular cytokines (e.g., IFN- $\gamma$ , TNF- $\alpha$ , IL-2)

#### Procedure:

- Cell Stimulation:
  - Plate PBMCs at a density of  $1-2 \times 10^6$  cells/mL in a 96-well plate.
  - Add the desired stimulation reagent to the cells.[3] For polyclonal T cell activation, a combination of PMA and Ionomycin or anti-CD3 antibodies can be used.[3][6]
  - Incubate for 4-6 hours at 37°C in a CO2 incubator.
  - For the last 2-4 hours of incubation, add a protein transport inhibitor to block cytokine secretion.[22]
- Surface Staining:
  - Harvest the cells and wash with flow cytometry staining buffer.
  - Resuspend the cells in staining buffer containing fluorochrome-conjugated antibodies against cell surface markers.
  - Incubate for 20-30 minutes at 4°C in the dark.
  - Wash the cells twice with staining buffer.
- Fixation and Permeabilization:
  - Resuspend the cells in fixation buffer and incubate for 20 minutes at room temperature in the dark.[3]
  - Wash the cells with permeabilization buffer.
- Intracellular Staining:

- Resuspend the fixed and permeabilized cells in permeabilization buffer containing fluorochrome-conjugated antibodies against intracellular cytokines.[3]
- Incubate for 30-45 minutes at room temperature in the dark.
- Wash the cells twice with permeabilization buffer.
- Data Acquisition:
  - Resuspend the cells in staining buffer and acquire data on a flow cytometer.

## Section 2: B Cell Activation Analysis

B cell activation is a key event in humoral immunity, leading to the production of antibodies. Ex vivo studies of B cell activation are crucial for understanding vaccine responses and autoimmune diseases.

### B Cell Receptor (BCR) Signaling Pathway

The B cell receptor (BCR) signaling pathway is initiated upon antigen binding, leading to a cascade of intracellular events that result in B cell proliferation, differentiation, and antibody production.[23]

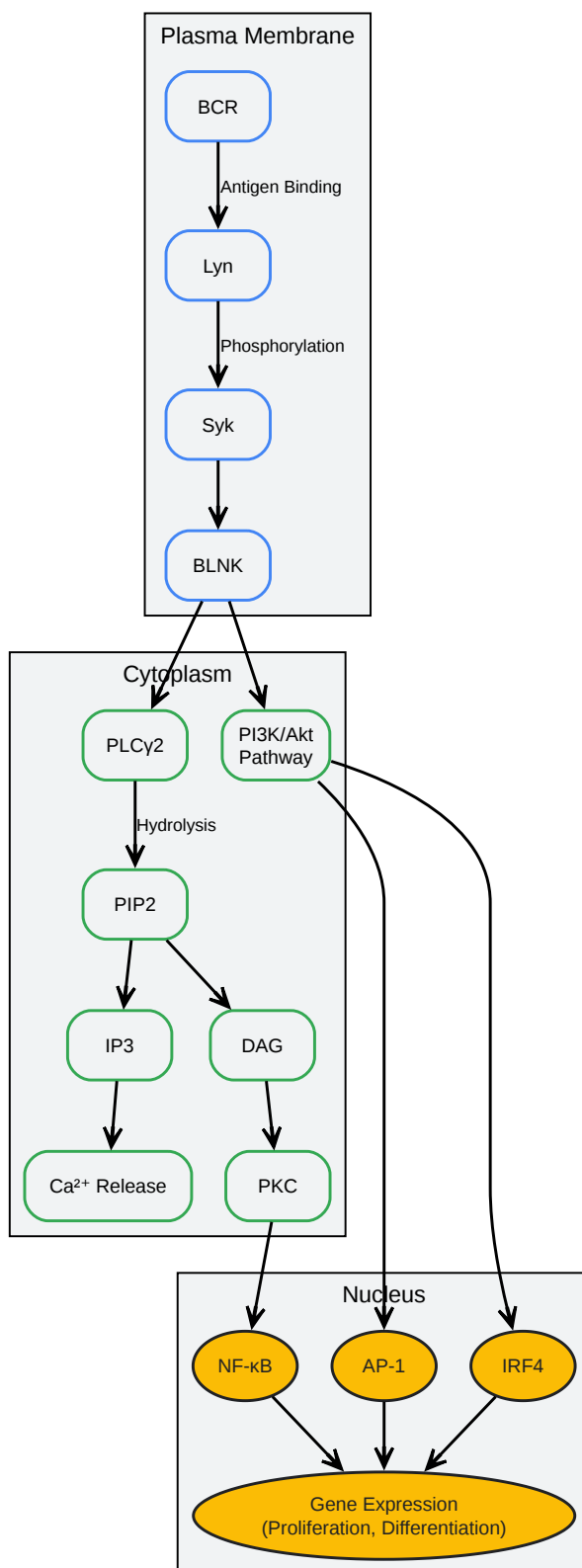

[Click to download full resolution via product page](#)

Caption: Simplified B Cell Receptor (BCR) signaling pathway.

## Quantitative Data Summary: B Cell Activation Markers

Stimulus	Cell Type	Activation Marker	Flow Cytometry (% positive cells)
Anti-IgM + Anti-CD40	Human B cells	CD69	40 - 80%
		CD86	30 - 70%
CpG ODN	Human B cells	CD69	30 - 60%
		CD86	20 - 50%
Unstimulated	Human B cells	CD69	< 5%
		CD86	< 10%

Note: Values are representative and can vary based on donor, reagents, and experimental conditions.

## Protocol: B Cell Activation and Proliferation Assay

Materials:

- Isolated B cells or PBMCs
- Cell culture medium
- B cell stimulation reagent (e.g., anti-IgM, anti-CD40, CpG ODN)
- Cell proliferation dye (e.g., CFSE)
- Flow cytometry staining buffer
- Fluorochrome-conjugated antibodies against B cell markers (e.g., CD19, CD20) and activation markers (e.g., CD69, CD86)

Procedure:

- Cell Labeling (Optional for Proliferation):

- Label isolated B cells or PBMCs with a cell proliferation dye according to the manufacturer's instructions.
- Cell Stimulation:
  - Plate the cells at an appropriate density.
  - Add the B cell stimulation reagent.
  - Incubate for 24-72 hours at 37°C.
- Staining:
  - Harvest the cells and wash with staining buffer.
  - Stain with fluorochrome-conjugated antibodies against B cell and activation markers.
  - Incubate for 20-30 minutes at 4°C.
  - Wash the cells twice.
- Data Acquisition:
  - Resuspend the cells in staining buffer and acquire data on a flow cytometer. Proliferation is assessed by the dilution of the proliferation dye.

## Section 3: Monocyte and Dendritic Cell Activation Analysis

Monocytes and dendritic cells (DCs) are key players in the innate immune system and are critical for initiating adaptive immune responses. Their activation is often studied in the context of pathogen recognition and inflammation.

### Toll-Like Receptor (TLR) Signaling Pathway

Toll-like receptors (TLRs) are pattern recognition receptors that recognize pathogen-associated molecular patterns (PAMPs), triggering innate immune responses.[\[24\]](#)[\[25\]](#)

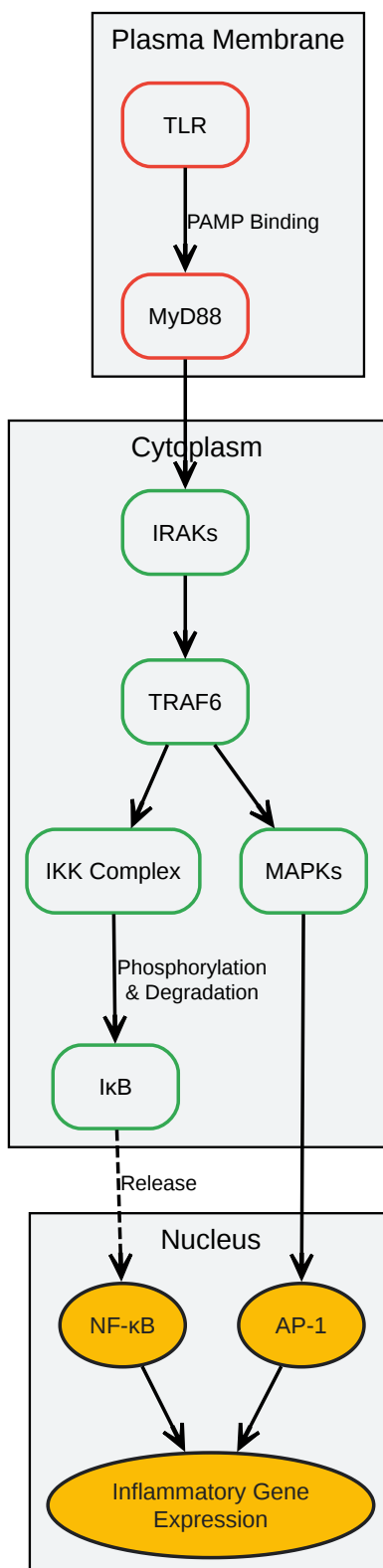

[Click to download full resolution via product page](#)

Caption: Simplified Toll-Like Receptor (TLR) signaling pathway (MyD88-dependent).

## Quantitative Data Summary: Monocyte and DC Cytokine Production

Stimulus	Cell Type	Cytokine	Multiplex Assay (pg/mL)
LPS (100 ng/mL)	Human Monocytes	TNF- $\alpha$	2000 - 10000
IL-6	1000 - 8000		
IL-1 $\beta$	500 - 3000		
LPS (100 ng/mL)	Human mo-DCs	TNF- $\alpha$	1000 - 5000
IL-12p70	100 - 1000		
IL-6	500 - 4000		
Unstimulated	Human Monocytes/DCs	All	< 50

Note: Values are representative and can vary based on donor, culture conditions, and assay platform.

## Protocol: Ex Vivo Whole Blood Assay for Monocyte Activation

Materials:

- Freshly collected human whole blood in sodium heparin tubes
- RPMI-1640 medium
- Stimulating agent (e.g., Lipopolysaccharide - LPS)
- 96-well culture plate
- Centrifuge
- ELISA or Multiplex bead array kit for cytokine measurement

#### Procedure:

- Blood Collection and Dilution:
  - Collect venous blood from healthy volunteers into sodium-heparin tubes.[13]
  - Within 2 hours of collection, dilute the blood 1:1 with RPMI-1640 medium.
- Stimulation:
  - Add 200  $\mu$ L of the diluted blood to each well of a 96-well plate.
  - Add the stimulating agent (e.g., LPS to a final concentration of 10-100 ng/mL) or medium alone (unstimulated control).
  - Incubate for 4-24 hours at 37°C in a 5% CO<sub>2</sub> incubator.[11]
- Sample Collection:
  - After incubation, centrifuge the plate to pellet the blood cells.
  - Carefully collect the plasma supernatant without disturbing the cell pellet.
- Cytokine Analysis:
  - Analyze the plasma samples for cytokine concentrations using an ELISA or a multiplex bead array according to the manufacturer's instructions.[11][13]

## Section 4: NF- $\kappa$ B Signaling Pathway

The NF- $\kappa$ B (nuclear factor kappa-light-chain-enhancer of activated B cells) signaling pathway is a central regulator of immune and inflammatory responses.[26][27][28] Its activation is a common downstream event for many immune cell activation pathways.

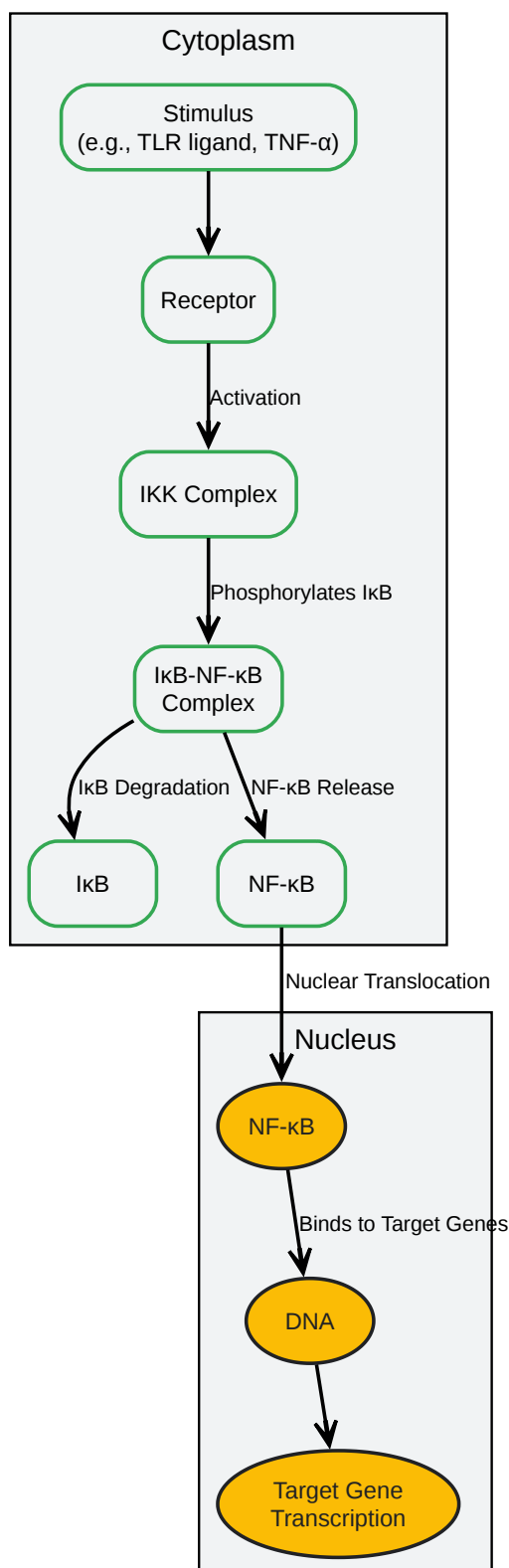

[Click to download full resolution via product page](#)

Caption: Canonical NF-κB signaling pathway.

## Conclusion

The ex vivo analysis of immune cell activation provides a powerful platform for understanding fundamental immunology and for the development of novel therapeutics. The protocols and guidelines presented in this document offer a framework for conducting these assays in a standardized and reproducible manner. Careful experimental design, appropriate controls, and multi-parametric readouts are essential for generating high-quality, interpretable data.

### *Need Custom Synthesis?*

*BenchChem offers custom synthesis for rare earth carbides and specific isotopic labeling.*

*Email: [info@benchchem.com](mailto:info@benchchem.com) or [Request Quote Online](#).*

## References

- [1. T cell ELISPOT assay | U-CyTech \[ucytech.com\]](#)
- [2. ELISPOT Techniques - PubMed \[pubmed.ncbi.nlm.nih.gov\]](#)
- [3. Intracellular Cytokine Staining Protocol - Creative Bioarray | Creative Bioarray \[creative-bioarray.com\]](#)
- [4. anilocus.com \[anilocus.com\]](#)
- [5. cytek-web.s3.amazonaws.com \[cytek-web.s3.amazonaws.com\]](#)
- [6. BestProtocols: Staining Intracellular Antigens for Flow Cytometry | Thermo Fisher Scientific - US \[thermofisher.com\]](#)
- [7. Phosphoflow cytometry to assess cytokine signaling pathways in peripheral immune cells: potential for inferring immune cell function and treatment response in patients with solid tumors - PMC \[pmc.ncbi.nlm.nih.gov\]](#)
- [8. Phospho Flow Cytometry Methods for the Analysis of Kinase Signaling in Cell Lines and Primary Human Blood Samples | Springer Nature Experiments \[experiments.springernature.com\]](#)
- [9. creative-diagnostics.com \[creative-diagnostics.com\]](#)
- [10. 2024.sci-hub.se \[2024.sci-hub.se\]](#)
- [11. dovepress.com \[dovepress.com\]](#)

- 12. Cell Activation and Cytokine Release Ex Vivo: Estimation of Reproducibility of the Whole-Blood Assay with Fresh Human Blood - PubMed [[pubmed.ncbi.nlm.nih.gov](https://pubmed.ncbi.nlm.nih.gov)]
- 13. Whole blood assay as a model for in vitro evaluation of inflammasome activation and subsequent caspase-mediated interleukin-1 beta release - PMC [[pmc.ncbi.nlm.nih.gov](https://pmc.ncbi.nlm.nih.gov)]
- 14. Whole blood stimulation as a tool for studying the human immune system - PubMed [[pubmed.ncbi.nlm.nih.gov](https://pubmed.ncbi.nlm.nih.gov)]
- 15. [immunology.org](https://immunology.org) [[immunology.org](https://immunology.org)]
- 16. [bio-rad.com](https://bio-rad.com) [[bio-rad.com](https://bio-rad.com)]
- 17. [web.mit.edu](https://web.mit.edu) [[web.mit.edu](https://web.mit.edu)]
- 18. T-cell antigen receptor signal transduction - PMC [[pmc.ncbi.nlm.nih.gov](https://pmc.ncbi.nlm.nih.gov)]
- 19. T cell signalling pathway | PPTX [[slideshare.net](https://slideshare.net)]
- 20. T-cell activation through the antigen receptor. Part 1: signaling components, signaling pathways, and signal integration at the T-cell antigen receptor synapse - PubMed [[pubmed.ncbi.nlm.nih.gov](https://pubmed.ncbi.nlm.nih.gov)]
- 21. [cusabio.com](https://cusabio.com) [[cusabio.com](https://cusabio.com)]
- 22. [researchgate.net](https://researchgate.net) [[researchgate.net](https://researchgate.net)]
- 23. The regulators of BCR signaling during B cell activation - PMC [[pmc.ncbi.nlm.nih.gov](https://pmc.ncbi.nlm.nih.gov)]
- 24. How toll-like receptors reveal monocyte plasticity: the cutting edge of antiinflammatory therapy - PMC [[pmc.ncbi.nlm.nih.gov](https://pmc.ncbi.nlm.nih.gov)]
- 25. [diabetesjournals.org](https://diabetesjournals.org) [[diabetesjournals.org](https://diabetesjournals.org)]
- 26. NF- $\kappa$ B in immunobiology - PMC [[pmc.ncbi.nlm.nih.gov](https://pmc.ncbi.nlm.nih.gov)]
- 27. NF- $\kappa$ B - Wikipedia [[en.wikipedia.org](https://en.wikipedia.org)]
- 28. [creative-diagnostics.com](https://creative-diagnostics.com) [[creative-diagnostics.com](https://creative-diagnostics.com)]
- To cite this document: BenchChem. [Ex Vivo Analysis of Immune Cell Activation: Application Notes and Protocols]. BenchChem, [2026]. [Online PDF]. Available at: [<https://www.benchchem.com/product/b10782765/docs#ex-vivo-analysis-of-immune-cell-activation-application-notes-and-protocols>]

---

### Disclaimer & Data Validity:

The information provided in this document is for Research Use Only (RUO) and is strictly not intended for diagnostic or therapeutic procedures. While BenchChem strives to provide

accurate protocols, we make no warranties, express or implied, regarding the fitness of this product for every specific experimental setup.

**Technical Support:** The protocols provided are for reference purposes. Unsure if this reagent suits your experiment?

**Need Industrial/Bulk Grade?** [Request Custom Synthesis Quote](#)

## BenchChem

Our mission is to be the trusted global source of essential and advanced chemicals, empowering scientists and researchers to drive progress in science and industry.

### Contact

Address: 3281 E Guasti Rd

Ontario, CA 91761, United States

Phone: (601) 213-4426

Email: [info@benchchem.com](mailto:info@benchchem.com)

[Contact our Ph.D. Support Team for a compatibility check](#)